

AC Motor Drive Using Cosimulation

Motors integrated with advanced power-electronic converters enable more-efficient operation and deliver improved performance. However, these integrated electronic designs pose significant challenges to design engineers. When designing an AC drive, engineers face a wide variety of problems in combining several engineering domains that interact within the device. Using the Ansys motor and drive design workflow offers many advantages for this application.

Products Used:

Ansys Maxwell®
Ansys Simplorer®

The AC motor is an alternating-current electrical machine in the sense that the sine-wave phase currents that drive the motor change polarity every half cycle. To achieve this sine-wave current excitation, the DC supply voltage is applied to an inverter circuit using power device switches, which are switched on and off at a high frequency. Controlling how the power switches are turned on and off can be accomplished by a number of methods. One of these incorporates pulse-width modulation (PWM). PWM uses sinusoidal reference waveforms to control the switching, which forces motor drive currents to follow the reference waveforms. To accurately design and predict performance of the interactions throughout the entire drive system, you must simulate and model the power electronics inverter, power devices, control logic and high-fidelity motor model. Ansys provides a vast suite of simulation, modeling and design capabilities that includes two tools especially applicable to this type of design.

Ansys Simplorer offers capabilities for systems and circuits and is known for its power electronics abilities. Simplorer provides detailed power device characterization, a large library of models, versatile modeling capabilities and robust simulation back plane for difficult power electronics applications. Simplorer is ideal for designing and modeling the power electronics part of the AC motor drive.

Ansys Maxwell offers finite element analysis (FEA) capabilities that can be applied to a variety of power electronics components, such as magnetic actuators, transformers, motors and generators. Maxwell's FEA provides the most accurate method for motor design and modeling: its Maxwell equations take into account physics fundamentals. The cosimulation capability between Simplorer and Maxwell enables high-fidelity coupling of power electronics motor drive circuitry and detailed motor modeling.

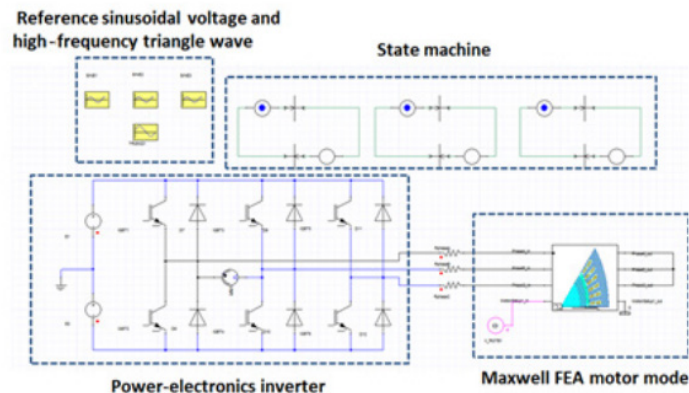

Figure 1. AC motor drive system in Simplorer using control blocks for reference voltage and high-frequency triangular waveform, state machine for control logic, power electronics inverter using system-level IGBTs and finite element Maxwell motor model.

Figure 1 shows the motor drive system in Simplorer. The system is divided into four sections: reference voltage and high-frequency triangle waveform, state machine, power-electronics inverter, and Maxwell FEA motor model. The reference voltages are compared to the high-frequency triangular waveform as shown in Figure 2. There are three reference sinusoidal waveforms because the motor is a three-phase AC machine. The state machine implements the PWM control logic design that controls turning on and off the power device switches. When the reference voltage is greater than the triangular waveform, the state machine generates a 1; if the reference voltage is less than the triangular waveform, the state machine generates a 0. One of the six PWM signals generated by the state machine is shown in Figure 3.

Simplorer provides several levels of power device modeling, from system level to very detailed dynamic switching characteristic levels. The system-level IGBTs in this example are used to quickly evaluate the digital control logic required when a 1 turns on the IGBT switch and 0 turns off the IGBT. The PWM signals switch on and off the power-electronics IGBTs of the inverter to generate the desired sinusoidal currents to drive the AC motor. Figure 4 shows the three-phase current waveforms generated by the inverter. Notice that the currents have ripple due to PWM modulation (which is seen in actual test data). Figure 5 shows the torque produced by the Maxwell FEA motor model. The motor windings are energized by the currents generated from the inverter, producing a rotating magnetic field that interacts with the rotor magnets and thus producing a usable mechanical torque. Figure 6 shows the magnetic flux density and flux line distribution in the motor cross section. Simplorer–Maxwell cosimulation enables the user to have access to field results while taking into account the realistic drive currents generated by the inverter.

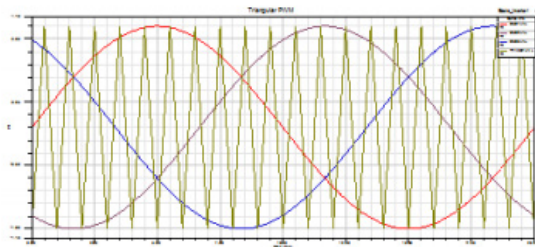

Figure 2. PID control with step response and AC response.

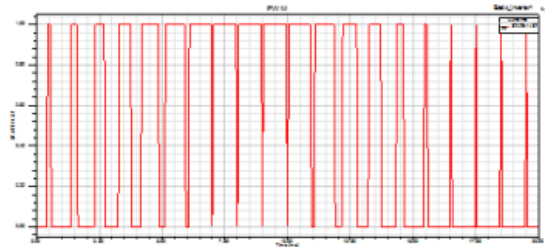

Figure 3. Signal processing example of current flowing between controlled rectifier and three-phase load demonstrates that a signal can be analyzed at a specified sampling frequency.

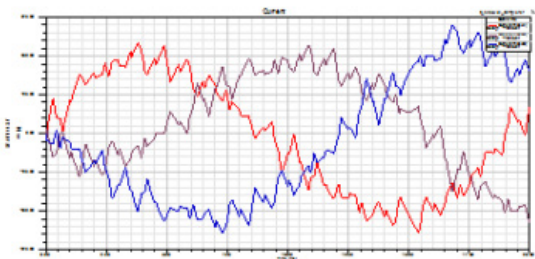

Figure 4. Three-phase current waveforms generated by inverter to drive Maxwell motor model.

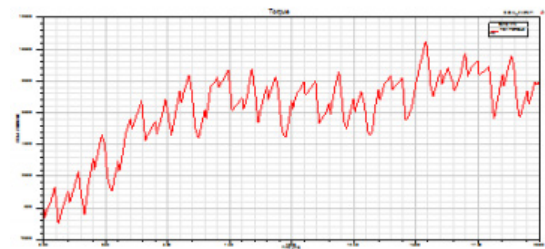

Figure 5. Torque produced by Maxwell FEA motor model.

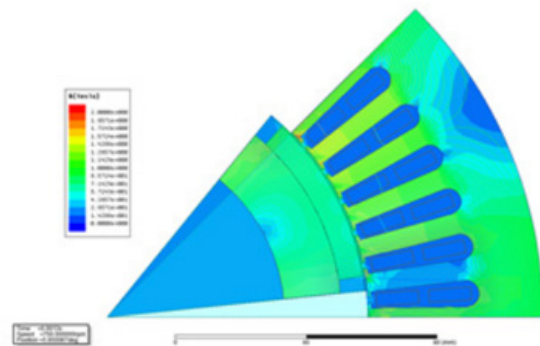

Figure 6. Line voltages and motor currents in machine control example (from Figures 3 and 4).

/ Summary

To design an AC motor drive, it is important to have the ability to model and simulate the different sections and their interactions. An AC motor drive system that includes control logic, power electronics inverter and FEA motor model was shown by using Simplorer–Maxwell cosimulation capability. This cosimulation allows the highest level of accuracy and predicts realistic voltage and current generated from the inverter drive, as well as the performance of the motor.

Boston Engineering
300 Bear Hill Road Waltham, MA 02451
www.boston-engineering.com

If you've ever seen a rocket launch, flown on an airplane, driven a car, used a computer, touched a mobile device, crossed a bridge or put on wearable technology, chances are you've used a product where Ansys software played a critical role in its creation. Ansys is the global leader in engineering simulation. We help the world's most innovative companies deliver radically better products to their customers. By offering the best and broadest portfolio of engineering simulation software, we help them solve the most complex design challenges and engineer products limited only by imagination.

Visit www.boston-engineering.com for more information.

Any and all ANSYS, Inc. brand, product, service and feature names, logos and slogans are registered trademarks or trademarks of Ansys, Inc. or its subsidiaries in the United States or other countries. All other brand, product, service and feature names or trademarks are the property of their respective owners.

© 2020 ANSYS, Inc. All Rights Reserved.