



US010799223B2

(12) **United States Patent**  
**Furlong et al.**

(10) **Patent No.:** **US 10,799,223 B2**

(45) **Date of Patent:** **\*Oct. 13, 2020**

(54) **INSERTABLE ENDOSCOPIC INSTRUMENT FOR TISSUE REMOVAL**

(58) **Field of Classification Search**  
CPC . A61B 1/00094; A61B 1/00133; A61B 1/015;  
A61B 1/018; A61B 1/31;  
(Continued)

(71) Applicant: **Interscope, Inc.**, Whitinsville, MA (US)

(72) Inventors: **Cosme Furlong**, Whitinsville, MA (US); **Michael W. Marcoux**, Whitinsville, MA (US); **Richard Stephen Wisdom**, Hydepark, MA (US); **William R. Rebh, Jr.**, Shrewsbury, MA (US); **Evan Costa**, Newton, MA (US); **Stephen C. Evans**, Westford, MA (US)

(56) **References Cited**  
U.S. PATENT DOCUMENTS  
3,760,810 A 9/1973 Van Hoom  
3,834,392 A 9/1974 Lampman et al.  
(Continued)

(73) Assignee: **Interscope, Inc.**, Whitinsville, MA (US)

(\* ) Notice: Subject to any disclaimer, the term of this patent is extended or adjusted under 35 U.S.C. 154(b) by 500 days.  
This patent is subject to a terminal disclaimer.

FOREIGN PATENT DOCUMENTS  
CN 1933761 A 3/2007  
CN 202051784 11/2011  
(Continued)

(21) Appl. No.: **15/231,399**

OTHER PUBLICATIONS  
Office Action for JP2008/0249553 dated Nov. 8, 2016.  
(Continued)

(22) Filed: **Aug. 8, 2016**

(65) **Prior Publication Data**  
US 2017/0086801 A1 Mar. 30, 2017

*Primary Examiner* — Devin B Henson  
(74) *Attorney, Agent, or Firm* — Foley & Lardner LLP

**Related U.S. Application Data**

(63) Continuation of application No. 14/316,203, filed on Jun. 26, 2014, now Pat. No. 9,408,593, which is a  
(Continued)

(57) **ABSTRACT**  
An improved flexible endoscopic instrument to precisely and efficiently obtains samples of flat polyps and multiple polyps from a patient by debriding one or more polyps and retrieving the debrided polyps without having to alternate between using a separate cutting tool and a separate sample retrieving tool and may be used with an endoscope. In one aspect, the cutting tool is coupled to a flexible torque coil or torque rope that is configured to transfer rotational energy from a powered actuator through the length of the endoscope onto the cutting tool.

(51) **Int. Cl.**  
**A61B 10/04** (2006.01)  
**A61B 10/02** (2006.01)  
(Continued)

(52) **U.S. Cl.**  
CPC ..... **A61B 10/04** (2013.01); **A61B 1/005** (2013.01); **A61B 1/00094** (2013.01);  
(Continued)

**19 Claims, 70 Drawing Sheets**

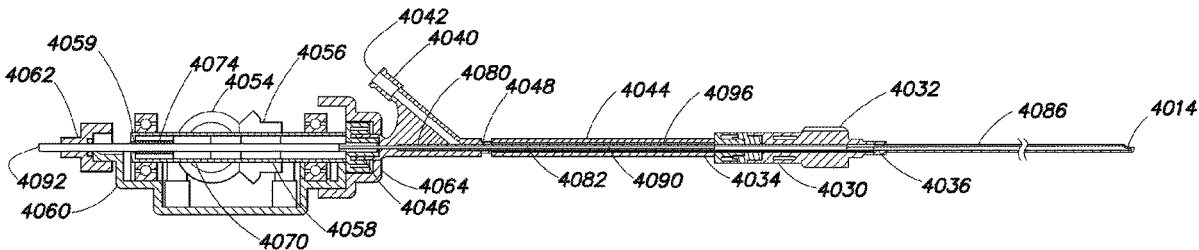

**Related U.S. Application Data**

- continuation of application No. 14/280,202, filed on May 16, 2014, now Pat. No. 8,882,680, which is a continuation-in-part of application No. 13/336,491, filed on Dec. 23, 2011, now Pat. No. 9,808,146.
- (60) Provisional application No. 61/824,760, filed on May 17, 2013, provisional application No. 61/566,472, filed on Dec. 2, 2011.
- (51) **Int. Cl.**  
*A61B 17/32* (2006.01)  
*A61B 17/3207* (2006.01)  
*A61B 17/00* (2006.01)  
*A61B 1/018* (2006.01)  
*A61B 1/31* (2006.01)  
*A61B 1/00* (2006.01)  
*A61B 1/005* (2006.01)  
*A61B 1/015* (2006.01)
- (52) **U.S. Cl.**  
 CPC ..... *A61B 1/00119* (2013.01); *A61B 1/00128* (2013.01); *A61B 1/00133* (2013.01); *A61B 1/015* (2013.01); *A61B 1/018* (2013.01); *A61B 1/31* (2013.01); *A61B 10/0266* (2013.01); *A61B 10/0275* (2013.01); *A61B 10/0283* (2013.01); *A61B 17/32002* (2013.01); *A61B 17/32* (2013.01); *A61B 17/320016* (2013.01); *A61B 17/320758* (2013.01); *A61B 2010/0208* (2013.01); *A61B 2010/0225* (2013.01); *A61B 2010/045* (2013.01); *A61B 2017/0034* (2013.01); *A61B 2017/00535* (2013.01); *A61B 2017/00553* (2013.01); *A61B 2017/00818* (2013.01); *A61B 2017/00973* (2013.01); *A61B 2017/320024* (2013.01); *A61B 2017/320032* (2013.01); *A61B 2017/320064* (2013.01); *A61B 2217/005* (2013.01); *A61B 2217/007* (2013.01)
- (58) **Field of Classification Search**  
 CPC . *A61B 10/04*; *A61B 10/0266*; *A61B 10/0275*; *A61B 17/320016*; *A61B 17/32002*; *A61B 2017/320032*; *A61B 2017/320064*; *A61B 2017/00973*; *A61B 2217/005*; *A61B 2217/007*  
 See application file for complete search history.
- (56) **References Cited**  
 U.S. PATENT DOCUMENTS  
 3,911,923 A 10/1975 Yoon  
 4,222,380 A 9/1980 Terayama  
 4,226,239 A 10/1980 Polk et al.  
 4,257,419 A 3/1981 Goltner et al.  
 4,548,201 A 10/1985 Yoon  
 4,646,738 A 3/1987 Trott  
 4,756,309 A 7/1988 Sachse et al.  
 4,763,667 A 8/1988 Manzo  
 4,834,729 A 5/1989 Sjostrom  
 4,850,957 A 7/1989 Summers  
 4,950,278 A 8/1990 Sachse et al.  
 4,966,162 A 10/1990 Wang  
 5,269,789 A 12/1993 Chin et al.  
 5,287,845 A 2/1994 Faul et al.  
 5,320,630 A 6/1994 Ahmed  
 5,320,635 A 6/1994 Smith  
 5,349,940 A 9/1994 Takahashi et al.  
 5,417,697 A 5/1995 Wilk et al.  
 5,423,834 A 6/1995 Ahmed  
 5,462,559 A 10/1995 Ahmed  
 5,507,797 A 4/1996 Suzuki et al.  
 5,529,580 A 6/1996 Kusunoki et al.  
 5,662,671 A 9/1997 Barbut et al.  
 5,782,748 A 7/1998 Palmer et al.  
 5,871,453 A 2/1999 Banik et al.  
 5,906,615 A 5/1999 Thompson  
 5,938,680 A 8/1999 Ginn  
 5,961,534 A 10/1999 Banik et al.  
 6,001,112 A 12/1999 Taylor  
 6,059,719 A 5/2000 Yamamoto et al.  
 6,068,603 A 5/2000 Suzuki  
 6,193,672 B1 2/2001 Clement  
 6,245,011 B1 6/2001 Dudda et al.  
 6,517,560 B1 2/2003 Toth et al.  
 6,572,578 B1 6/2003 Blanchard  
 6,585,694 B1 7/2003 Smith et al.  
 6,645,218 B1 11/2003 Cassidy et al.  
 6,666,854 B1 12/2003 Lange  
 6,689,146 B1 2/2004 Himes  
 7,247,161 B2 7/2007 Johnston et al.  
 7,276,074 B2 10/2007 Adams et al.  
 7,625,347 B2 12/2009 Burbank et al.  
 7,691,110 B2 4/2010 Secrest et al.  
 7,857,784 B2 12/2010 Schmidberger et al.  
 8,070,756 B2 12/2011 Secrest et al.  
 8,070,762 B2 12/2011 Escudero et al.  
 8,123,750 B2 2/2012 Norton et al.  
 8,277,474 B2 10/2012 Norman et al.  
 8,435,259 B2 5/2013 Dierck  
 8,475,484 B2 7/2013 Wulfman et al.  
 8,528,563 B2 9/2013 Gruber  
 8,574,254 B2 11/2013 Hedstrom et al.  
 8,696,621 B2 4/2014 Gunday et al.  
 9,028,424 B2 5/2015 Furlong et al.  
 9,033,864 B2 5/2015 Furlong et al.  
 9,033,895 B2 5/2015 Furlong et al.  
 9,095,367 B2 8/2015 Olson et al.  
 9,408,593 B2\* 8/2016 Furlong ..... A61B 10/04  
 2001/0013487 A1 8/2001 Kaendler  
 2002/0013570 A1 1/2002 Ruegg et al.  
 2002/0058857 A1 5/2002 Smith  
 2003/0055315 A1 3/2003 Gatto et al.  
 2003/0097146 A1 5/2003 Montalvo et al.  
 2004/0147934 A1 7/2004 Kiestler  
 2004/0162572 A1 8/2004 Sauer  
 2005/0090848 A1 4/2005 Adams  
 2005/0159767 A1 7/2005 Adams et al.  
 2005/0272976 A1 12/2005 Tanaka et al.  
 2006/0229646 A1 10/2006 Sparks  
 2007/0038022 A1 2/2007 Nakao  
 2007/0129705 A1 6/2007 Trombley et al.  
 2007/0197871 A1 8/2007 Geitz et al.  
 2008/0082021 A1 4/2008 Ichikawa et al.  
 2008/0183201 A1 7/2008 Berberich  
 2008/0194910 A1 8/2008 Miyamoto et al.  
 2008/0234602 A1 9/2008 Oostman et al.  
 2008/0249553 A1 10/2008 Gruber et al.  
 2008/0290040 A1 11/2008 Kane et al.  
 2009/0069806 A1 3/2009 De La Mora Levy et al.  
 2009/0234378 A1 9/2009 Escudero et al.  
 2009/0240261 A1 9/2009 Drews et al.  
 2010/0010525 A1 1/2010 Lockard et al.  
 2010/0016757 A1 1/2010 Greenburg et al.  
 2010/0036375 A1 2/2010 Regadas  
 2010/0048992 A1 2/2010 Okada et al.  
 2010/0049225 A1 2/2010 To et al.  
 2010/0081874 A1 4/2010 Miyamoto et al.  
 2010/0121141 A1 5/2010 Rontal  
 2010/0168512 A1 7/2010 Rahmani  
 2010/0217245 A1 8/2010 Prescott  
 2010/0298855 A1 11/2010 Dierck  
 2011/0112364 A1 5/2011 Rone et al.  
 2011/0270126 A1 11/2011 Gunday et al.  
 2011/0298209 A1 12/2011 Nguyen et al.  
 2012/0109130 A1 5/2012 Casey et al.  
 2012/0226101 A1 9/2012 Tinkham et al.  
 2012/0226103 A1 9/2012 Gunday et al.  
 2013/0016316 A1 1/2013 Cheng et al.  
 2013/0046313 A1 2/2013 Sullivan et al.

(56)

**References Cited**

## U.S. PATENT DOCUMENTS

2013/0046316	A1	2/2013	Sullivan et al.
2013/0103067	A1	4/2013	Fabro et al.
2013/0190561	A1	7/2013	Oskin et al.
2013/0317529	A1	11/2013	Golden et al.
2014/0100567	A1	4/2014	Edwards et al.
2014/0155923	A1	6/2014	Edwards et al.
2014/0236165	A1	8/2014	Ries et al.
2014/0249448	A1	9/2014	Furlong et al.
2017/0172396	A1	6/2017	Nguyen et al.

## FOREIGN PATENT DOCUMENTS

CN	202051784	Y	11/2011
CN	103648356	A	3/2014
CN	104822331	B	5/2017
DE	33 39 322	A1	5/1984
DE	33 20 076	A1	12/1984
DE	19522403	A1	9/1997
EP	0 609 084	A2	8/1994
EP	1 031 371	A1	8/2000
EP	1 586 275		10/2005
EP	1 875 871	A2	1/2008
JP	2002-503132		1/2002
JP	2003-524479		8/2003
JP	2005-253892	A	9/2005
JP	2005-296412	A	10/2005
JP	2014-128465	A	7/2014
JP	5951919	B1	7/2016
WO	WO-95/30377		11/1995
WO	WO-99/11184	A1	3/1999
WO	WO-01/22889		4/2001
WO	WO-03/079911	A1	10/2003
WO	WO-2006/122279		11/2006
WO	WO-2012/075409	A1	6/2012
WO	WO-2013/022525		2/2013

## OTHER PUBLICATIONS

Canadian Examination Report on CA Application No. 2911545 dated Nov. 20, 2015.

Declaration of Non-Establishment of International Search Report dated Jan. 8, 2016 in PCT Application No. PCT/US2015/052980.

Examination Report for EP 12809398.6 dated Jul. 19, 2016.

Examination Report for EP 14731875.2 dated Aug. 17, 2016.

First Office Action dated Feb. 3, 2016 in Chinese Patent Application No. 201280068003.8.

International Preliminary Report on Patentability dated Nov. 26, 2015 in PCT Application No. PCT/US2014/038443.

International Preliminary Report on Patentability dated Jun. 12, 2014 in PCT Application No. PCT/US2012/067614.

International Search Report and Written Opinion dated May 28, 2013 in PCT App. No. PCT/US2012/067614.

International Search Report and Written Opinion for International Patent Application No. PCT/US2014/038443 dated Sep. 1, 2014.

International Search Report and Written Opinion of the International Searching Authority for International Application No. PCT/US2015/052977 dated Dec. 18, 2015.

International Search Report and Written Opinion of the International Searching Authority for International Application No. PCT/US2015/052979 dated Dec. 17, 2015.

International Search Report and Written Opinion of the International Searching Authority on International Application No. PCT/US2015/052978 dated Dec. 17, 2015.

Office Action for CN2014800030452 dated Aug. 22, 2016.

Office Action in European Patent Application No. 14731875.2 dated Feb. 12, 2016.

Office Action on U.S. Appl. No. 13/336,491 dated Oct. 26, 2016.

Patent Examination Report for AU 2012345690 dated Jul. 22, 2016.

Search Report for CN2012800680038 dated Oct. 18, 2016.

Search Report for CN2014800030452 dated Aug. 22, 2016.

Second Office Action for CN2012800680038 dated Oct. 18, 2016.

U.S. Notice of Allowance for U.S. Appl. No. 14/280,202 dated Oct. 7, 2014.

U.S. Notice of Allowance for U.S. Appl. No. 14/501,865 dated Feb. 20, 2015.

U.S. Notice of Allowance for U.S. Appl. No. 14/501,942 dated Mar. 18, 2015.

U.S. Notice of Allowance for U.S. Appl. No. 14/537,362 dated May 26, 2015.

U.S. Notice of Allowance in U.S. Appl. No. 14/501,957 dated Oct. 21, 2015.

U.S. Notice of Allowance on U.S. Appl. No. 14/316,203 dated Jun. 23, 2016.

U.S. Office Action for U.S. Appl. No. 13/336,491 dated Mar. 2, 2016.

U.S. Office Action for U.S. Appl. No. 13/336,491 dated Sep. 18, 2015.

U.S. Office Action for U.S. Appl. No. 14/280,202 dated Aug. 20, 2014.

U.S. Office Action for U.S. Appl. No. 14/316,203 dated Mar. 15, 2016.

U.S. Office Action for U.S. Appl. No. 14/501,865 dated Dec. 4, 2014.

U.S. Office Action for U.S. Appl. No. 14/501,932 dated Nov. 26, 2014.

U.S. Office Action for U.S. Appl. No. 14/501,942 dated Dec. 15, 2014.

U.S. Office Action for U.S. Appl. No. 14/501,957 dated Mar. 19, 2015.

U.S. Office Action for U.S. Appl. No. 14/501,957 dated Nov. 14, 2014.

U.S. Office Action for U.S. Appl. No. 14/537,362 dated Feb. 11, 2015.

U.S. Office Action on U.S. Appl. No. 13/336,491 dated May 11, 2016.

AU Office Action for AU Appl. No. 2017245419, dated Aug. 22, 2018.

European Search Report for application 17183220.7-1659 dated Nov. 3, 2017.

Examination Report No. 1 for Standard patent application for Application No. 2016201686, dated Mar. 1, 2017, 4 pages.

Examination report No. 2 for Standard Patent Application for Application No. 2012345609 dated Jun. 4, 2017.

Examination Search Report for CA Application No. 2,964,001 dated Jun. 19, 2017.

Extended Search Report for EP Application No. 17195661.8 dated Feb. 27, 2018.

Final Office Action on U.S. Appl. No. 14/792,369 dated Jun. 5, 2018.

Final Office Action on U.S. Appl. No. 14/961,425 dated Aug. 3, 2018.

First Office Action for AU Appl. No. 2017248536, dated Sep. 12, 2018.

First Office Action for AU Appl. No. 2018214129, dated Jan. 16, 2019.

First Office Action for CA Appl. No. 2857671, dated Sep. 17, 2018.

First Office Action for CN Appl. No. 201580065244.0, dated Sep. 19, 2018.

First Office Action for CN Appl. No. 201710192152.X, dated Feb. 27, 2019.

First Office Action for European Patent Office Appl. No. 15778839.9, dated Feb. 1, 2019.

First Office Action for European Patent Office Appl. No. 15778840.7-1113, dated Feb. 1, 2019.

First Office Action for JP Appl. No. 2016-114249, dated Apr. 25, 2019.

First Office Action for JP Patent Office Appl. No. 2018-046515, dated Dec. 5, 2018.

Fourth Office Action for CN Application No. 20120068003.8 dated Nov. 3, 2017.

Intention to Grant for EP Appl. No. 17183220.7, dated Aug. 10, 2018.

(56)

**References Cited**

OTHER PUBLICATIONS

International Preliminary Report and Written Opinion of the International Searching Authority for application No. PCT/US2015/052977 dated Apr. 4, 2017.  
International Preliminary Report on Patentability (Chapter 1 of the Patent Cooperation Treaty) and Written Opinion of the International Searching Authority for Application No. PCT/US2015/052978 dated Apr. 4, 2017.  
International Preliminary Report on Patentability and Written Opinion of the International Searching Authority for Application No. PCT/US2015/052979 dated Apr. 4, 2017.  
International Search Report and Written Opinion for PCT/US2017/022536 dated Aug. 10, 2017.  
International Search Report and Written Opinion for PCT/US2017/022536 dated Sep. 18, 2018.  
Japanese Office Action for Patent App. No. 2017-517015 dated Apr. 3, 2018.  
Japanese Office Action for application No. 2017-517005 dated Apr. 10, 2018.  
Non-Final Office Action on U.S. Appl. No. 16/386,692 dated Jun. 3, 2019.  
Notice of Allowance on U.S. Appl. No. 14/792,369 dated Dec. 6, 2018.

Notice of Allowance on U.S. Appl. No. 14/961,425 dated Dec. 12, 2018.  
Notification of Reasons for Refusal for application 2017-517011 dated Apr. 3, 2018.  
Office Action for JP 2016-114249 dated Jun. 6, 2017.  
Office Action for JP Application No. 2017-517005 dated Apr. 10, 2018.  
Office Action for U.S. Appl. No. 14/792,369 dated Oct. 17, 2017.  
Office Action on U.S. Appl. No. 13/336,491 dated Jan. 19, 2017.  
Office Action on U.S. Appl. No. 14/961,425 dated Feb. 8, 2018.  
The EndoRotor Mucosal Resection System Procedural Guide, 2017, Interscope, Inc. LAB-0002 REV.  
The EndoRotor Mucosal Resection System Procedural Guide, LAB-0005 2017 Interscope, Inc., 6 pages.  
Third Office Action for Application No. 201280068003.8 dated Apr. 17, 2017, 6 pages.  
U.S. Notice of Allowance on U.S. Appl. No. 13/336,491 dated Jul. 6, 2017.  
U.S. Notice of Allowance on U.S. Appl. No. 13/336,491 dated Aug. 7, 2017.  
Final Office Action on U.S. Appl. No. 16/386,692 dated Oct. 22, 2019.  
Second Office Action on CN 201710192152.X dated Oct. 24, 2019.

\* cited by examiner

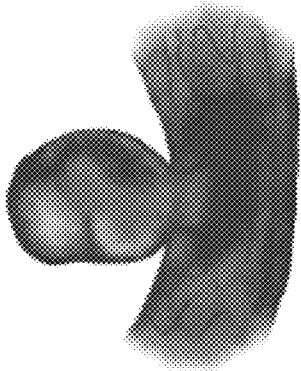

**Stalked**

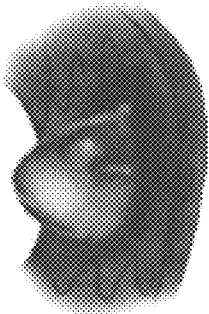

**Sessile**



**Flat**

Figure 1A

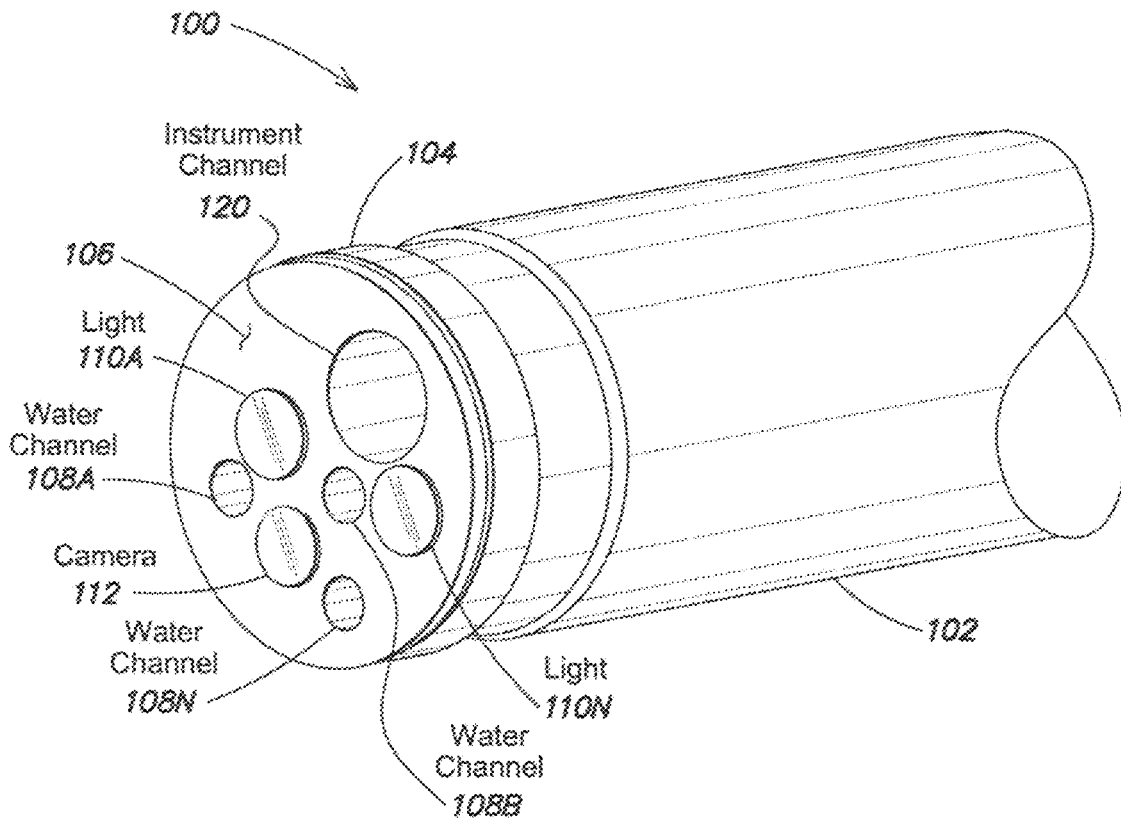

Figure 1B

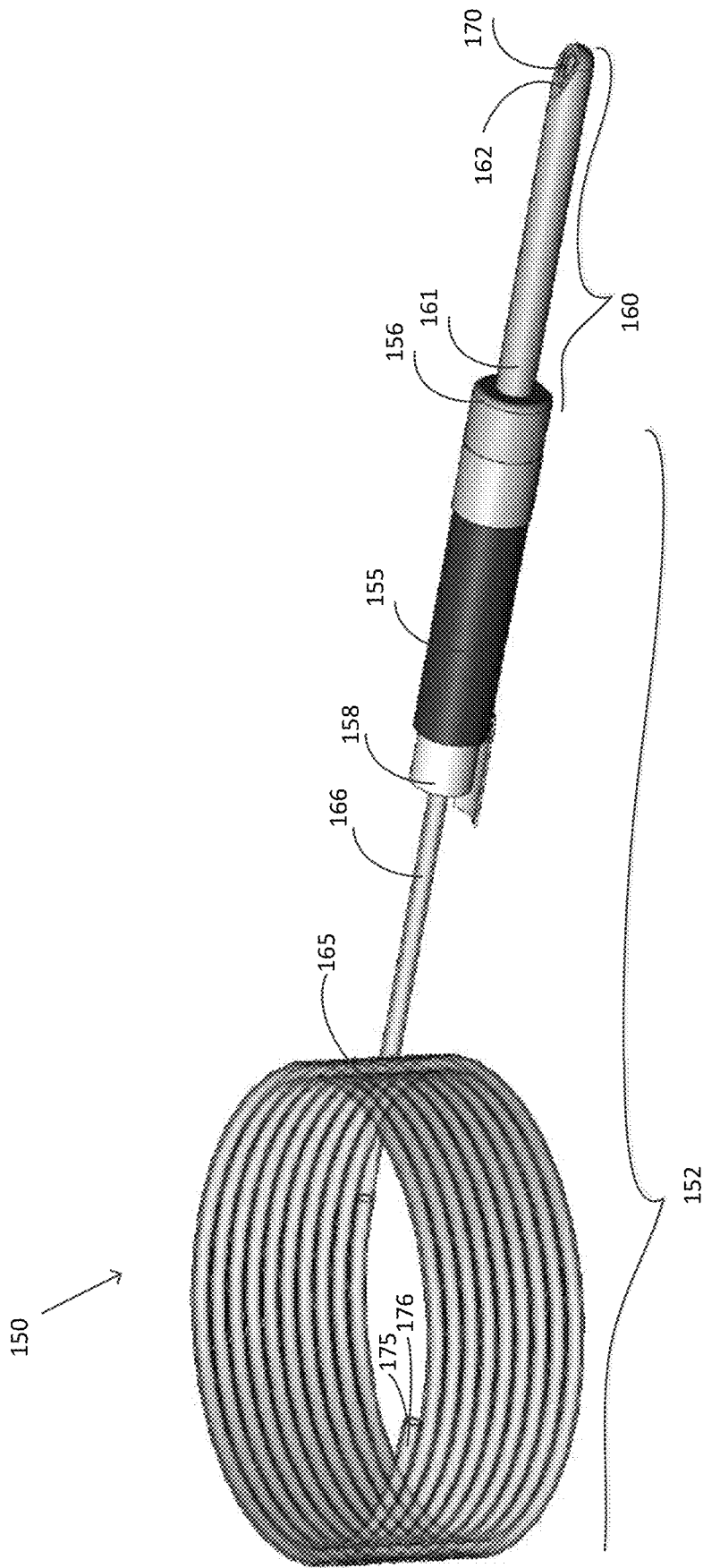

Figure 1C

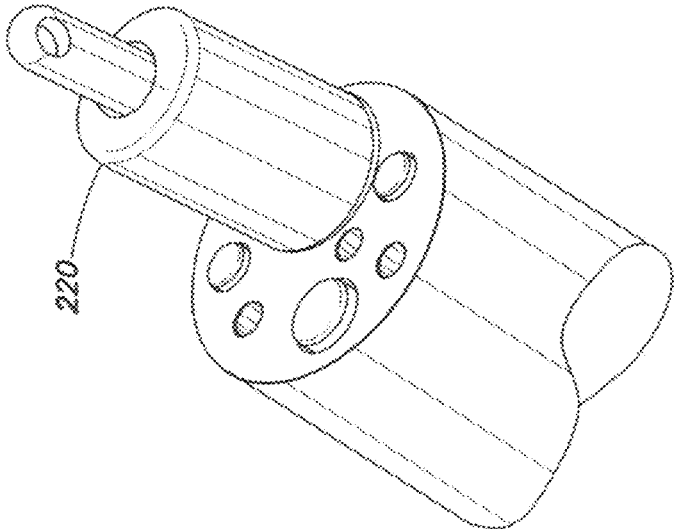

FIG. 2B

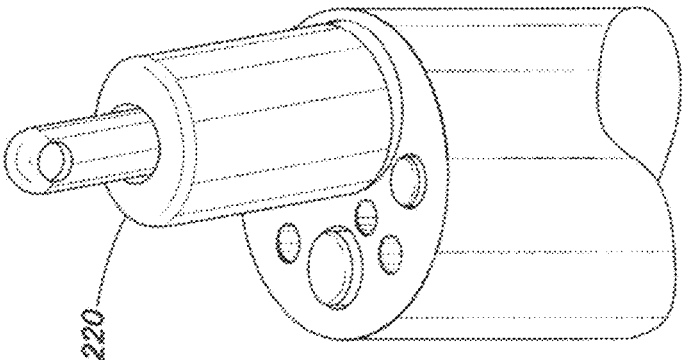

FIG. 2A



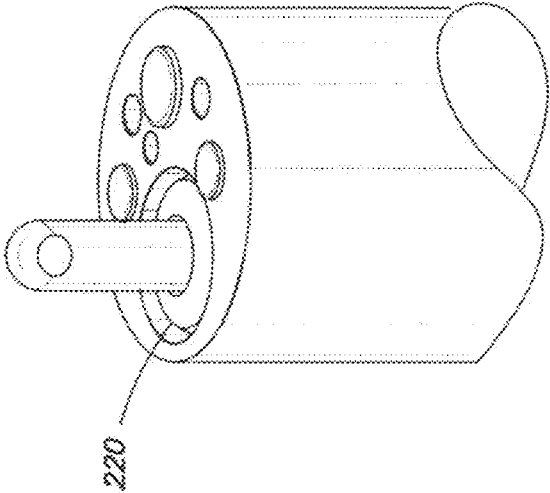

FIG. 3B

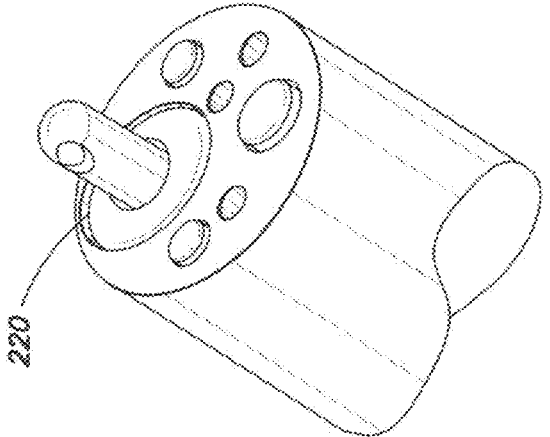

FIG. 3A

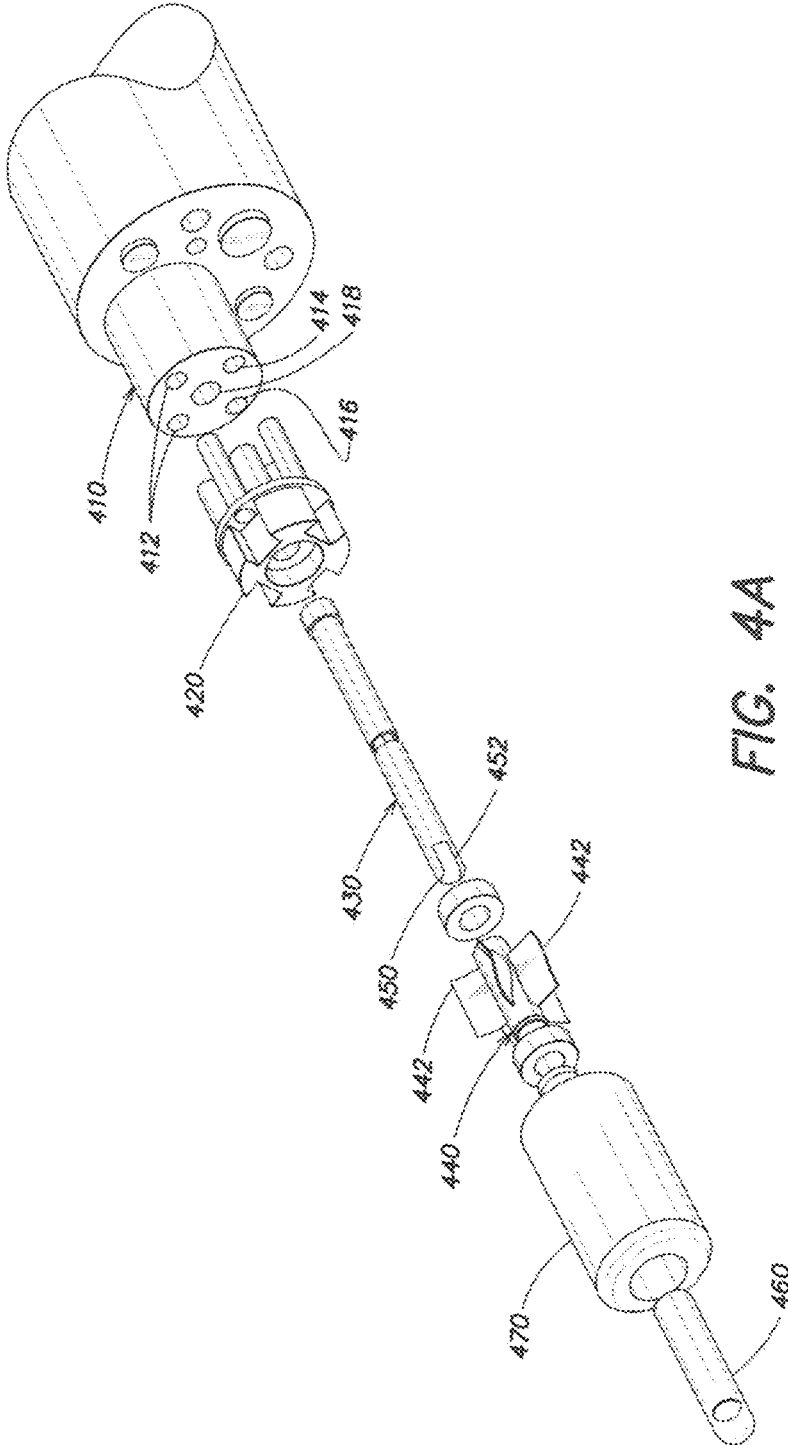

FIG. 4A

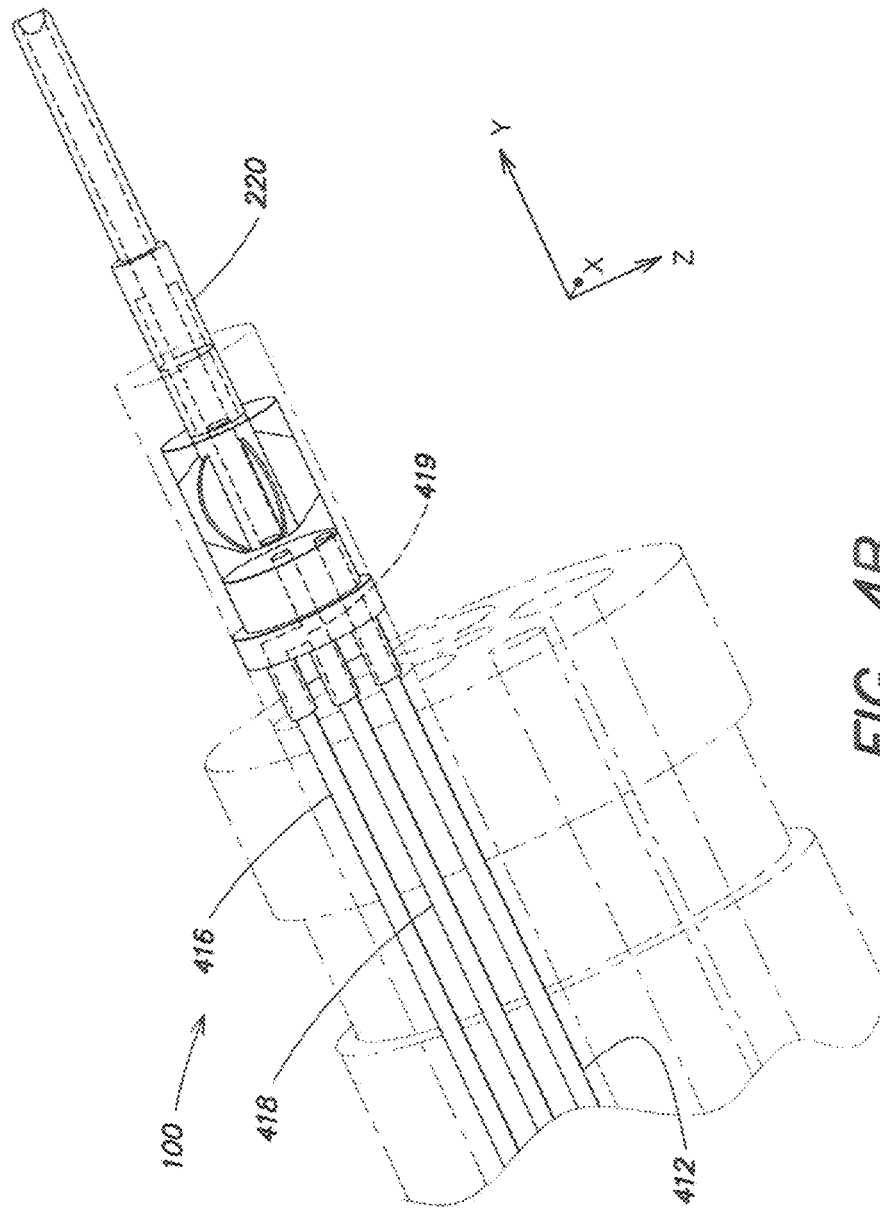

FIG. 4B

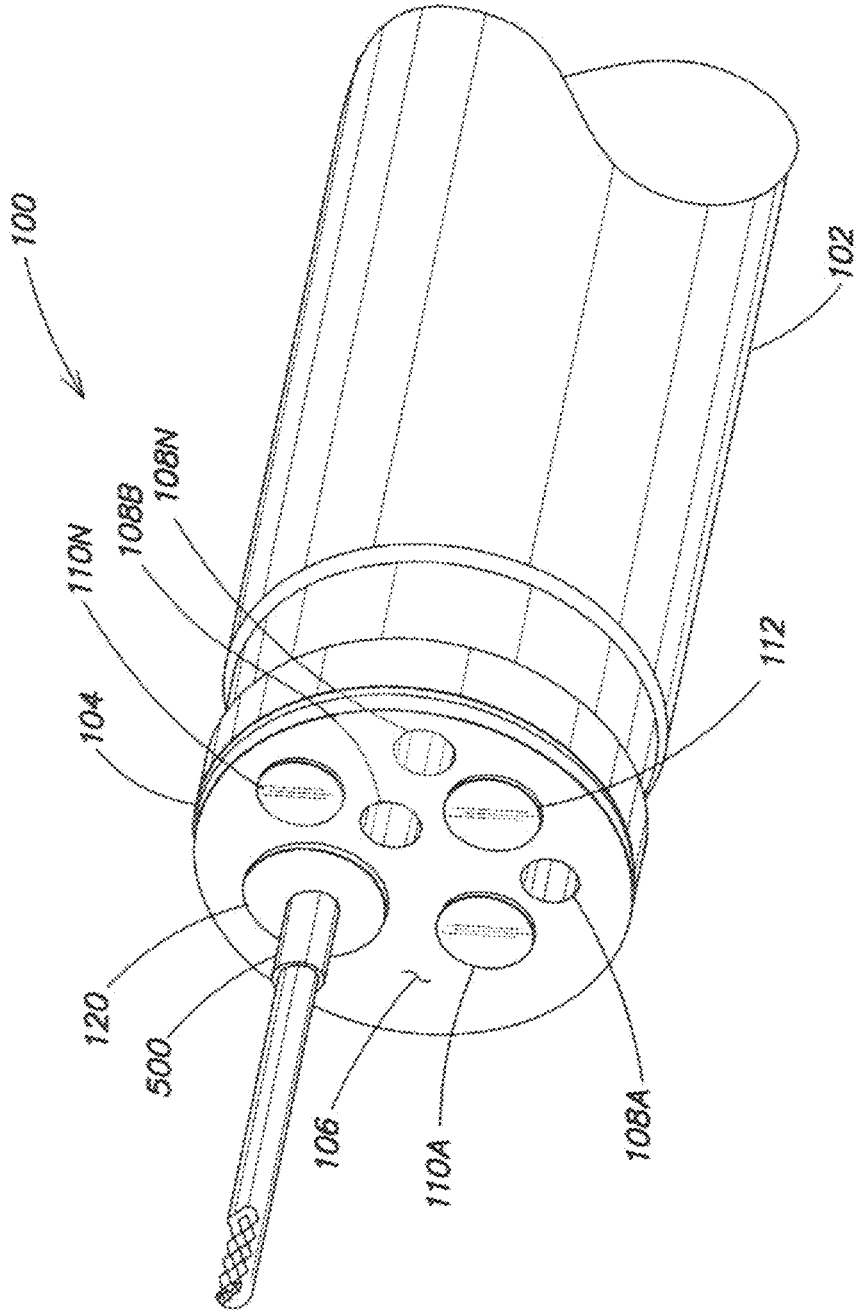

FIG. 5

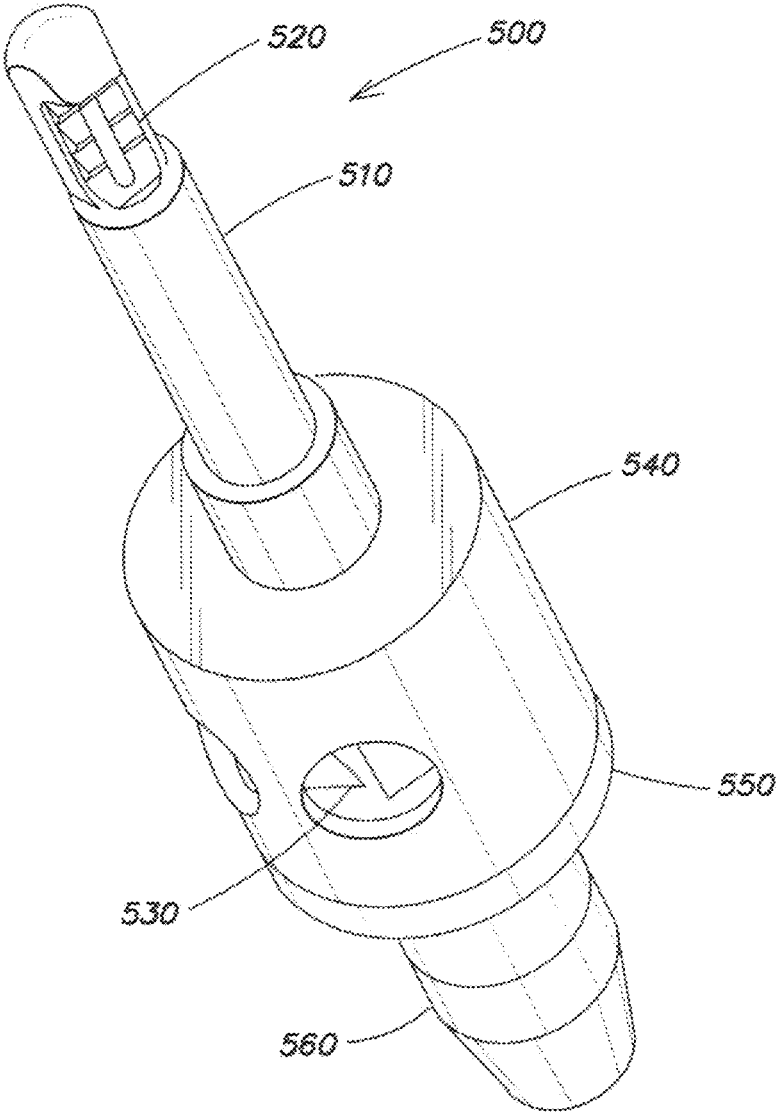

FIG. 6

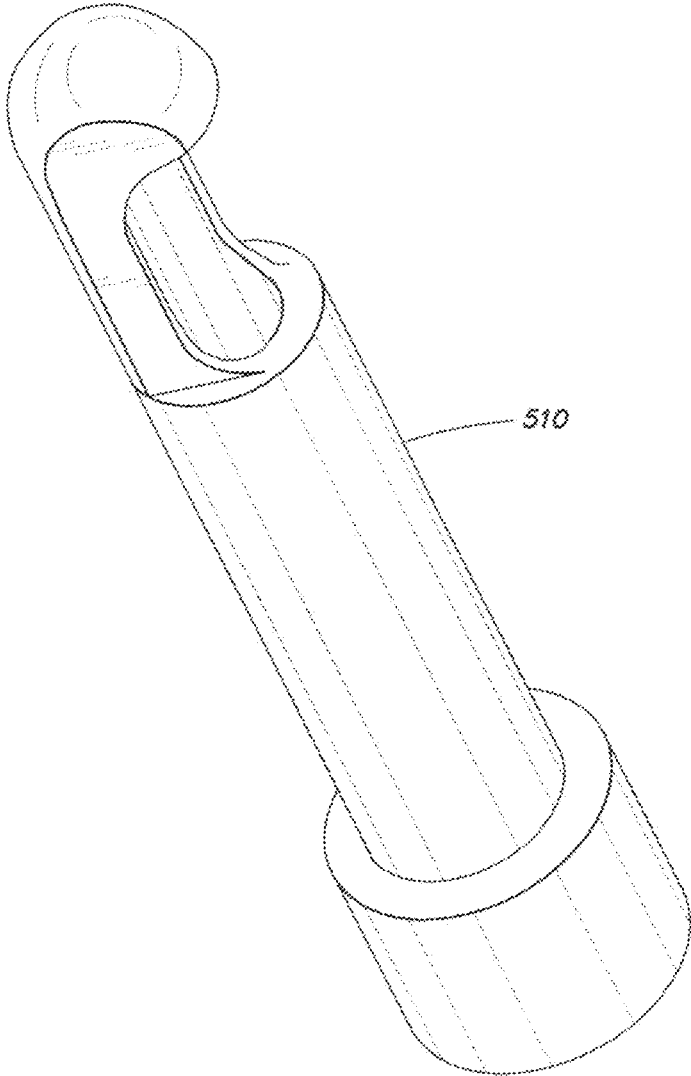

FIG. 7

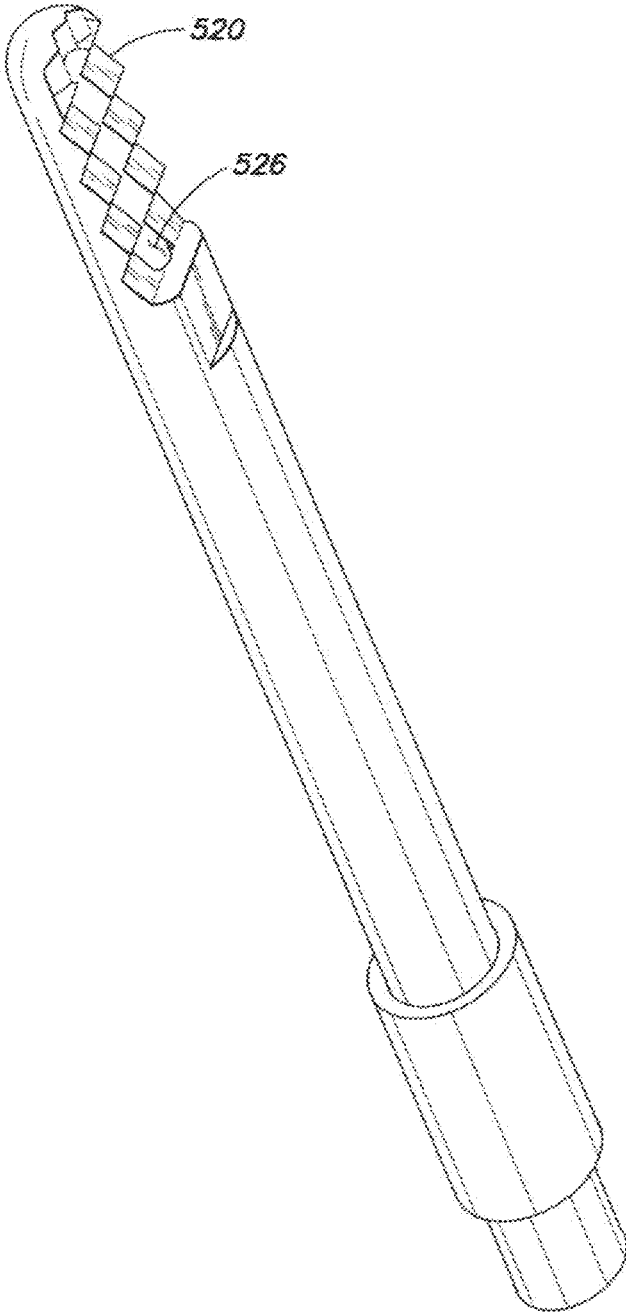
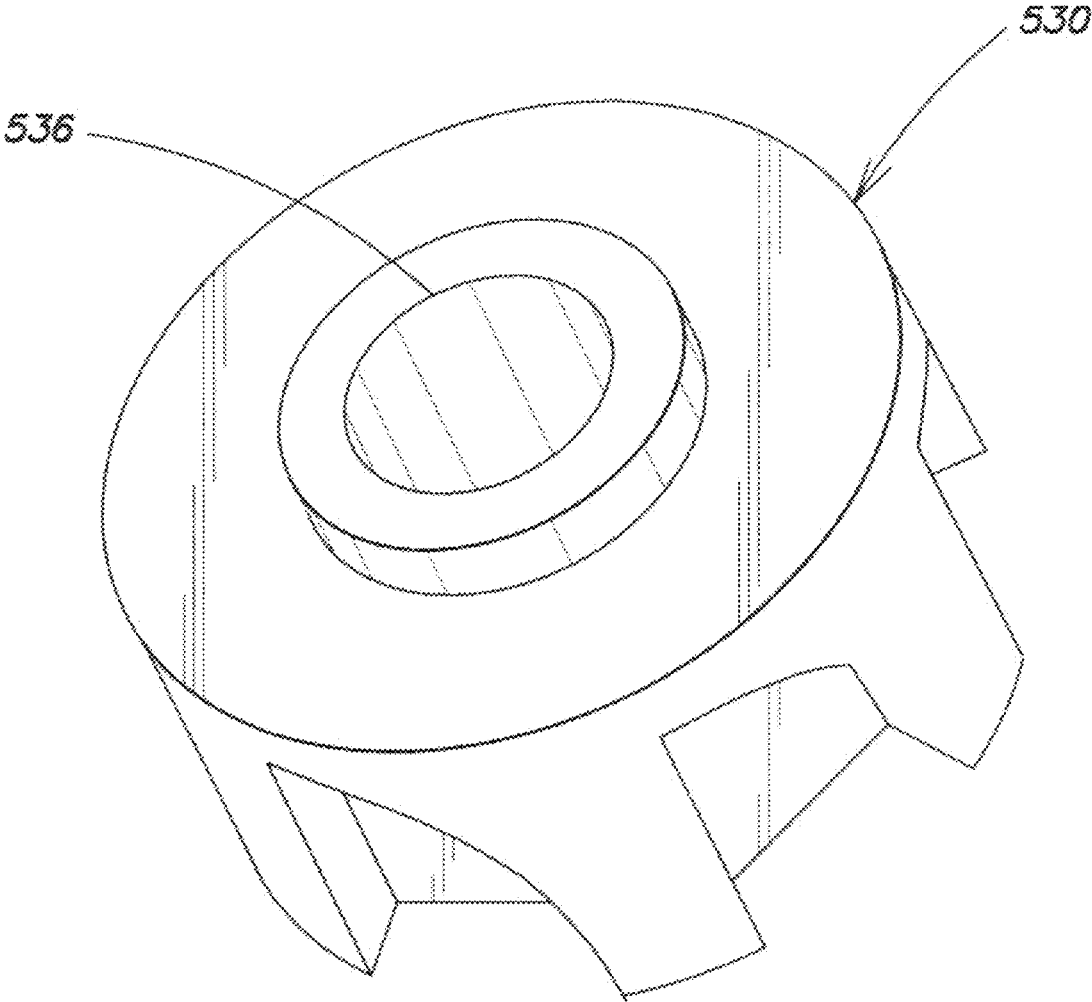
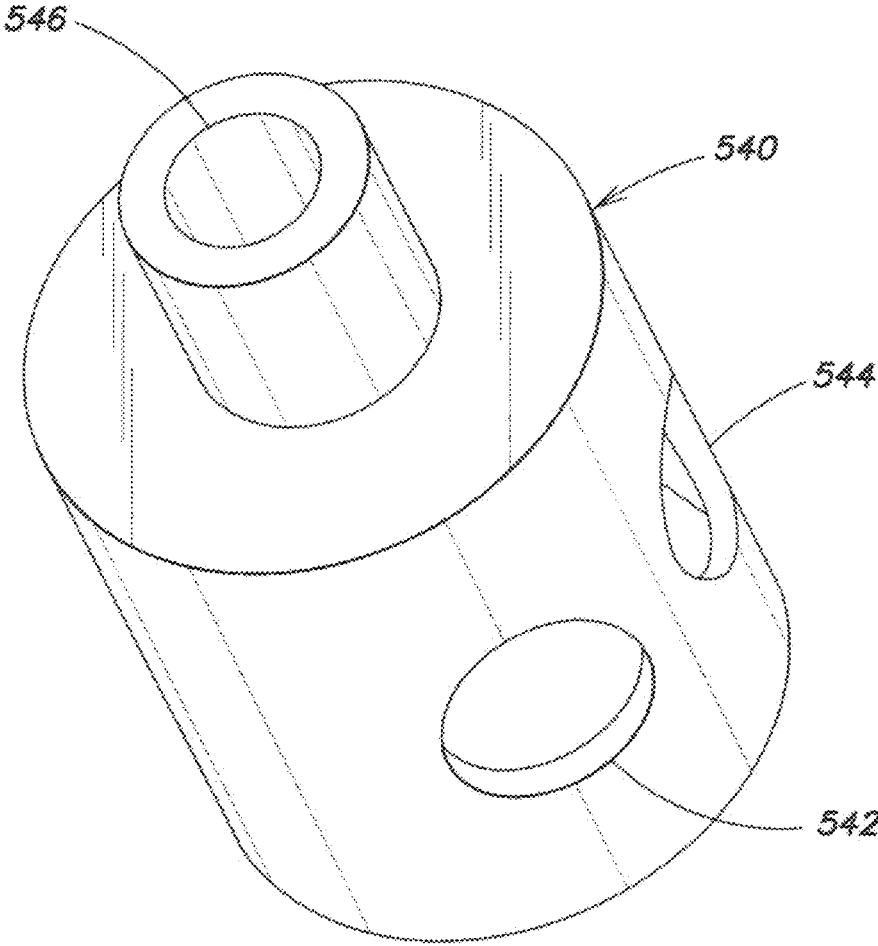

FIG. 8

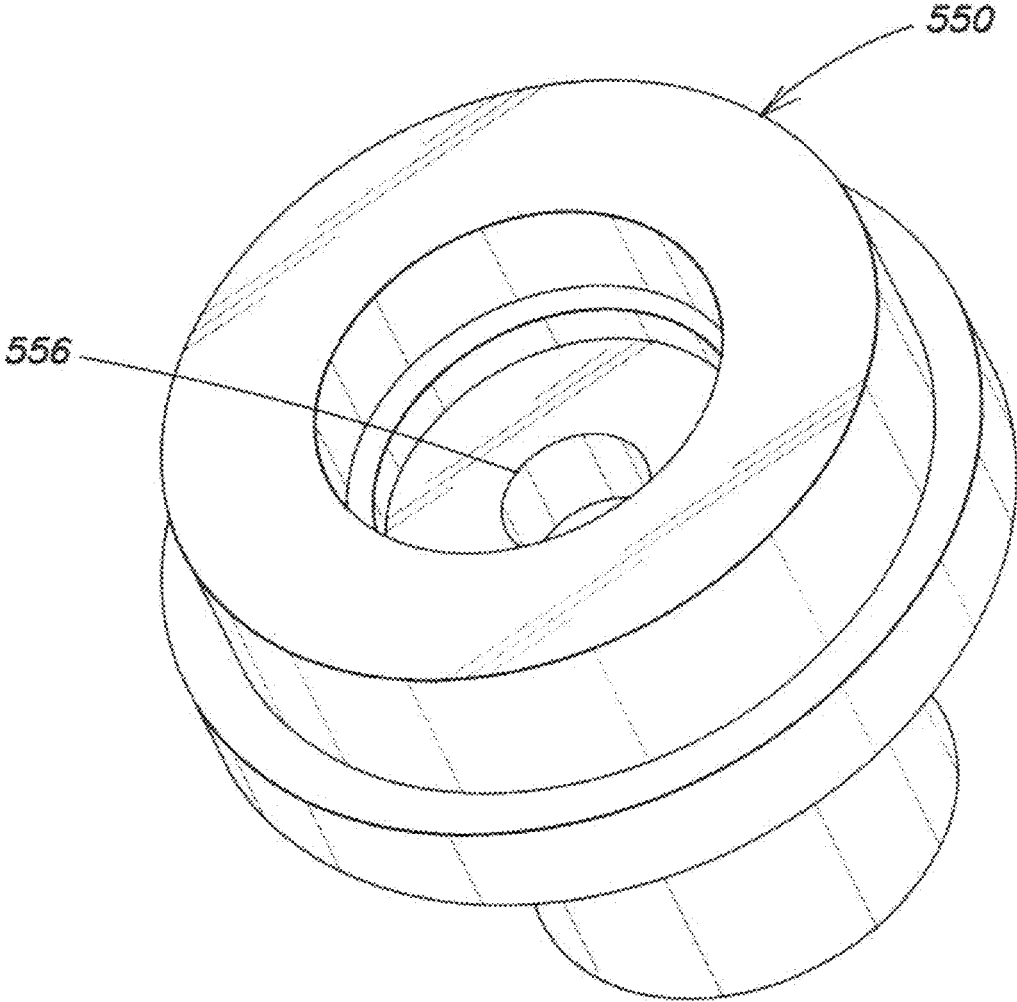

**FIG. 9**

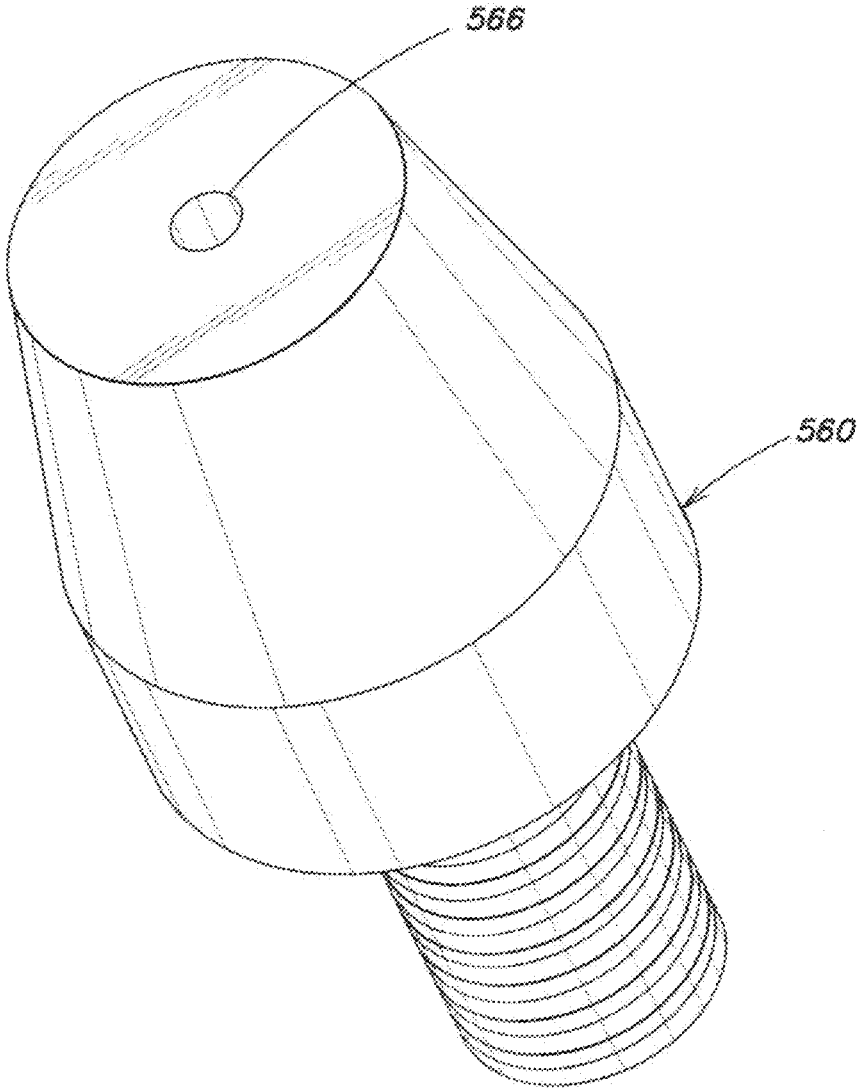



*FIG. 10*



**FIG. 11**



**FIG. 12**

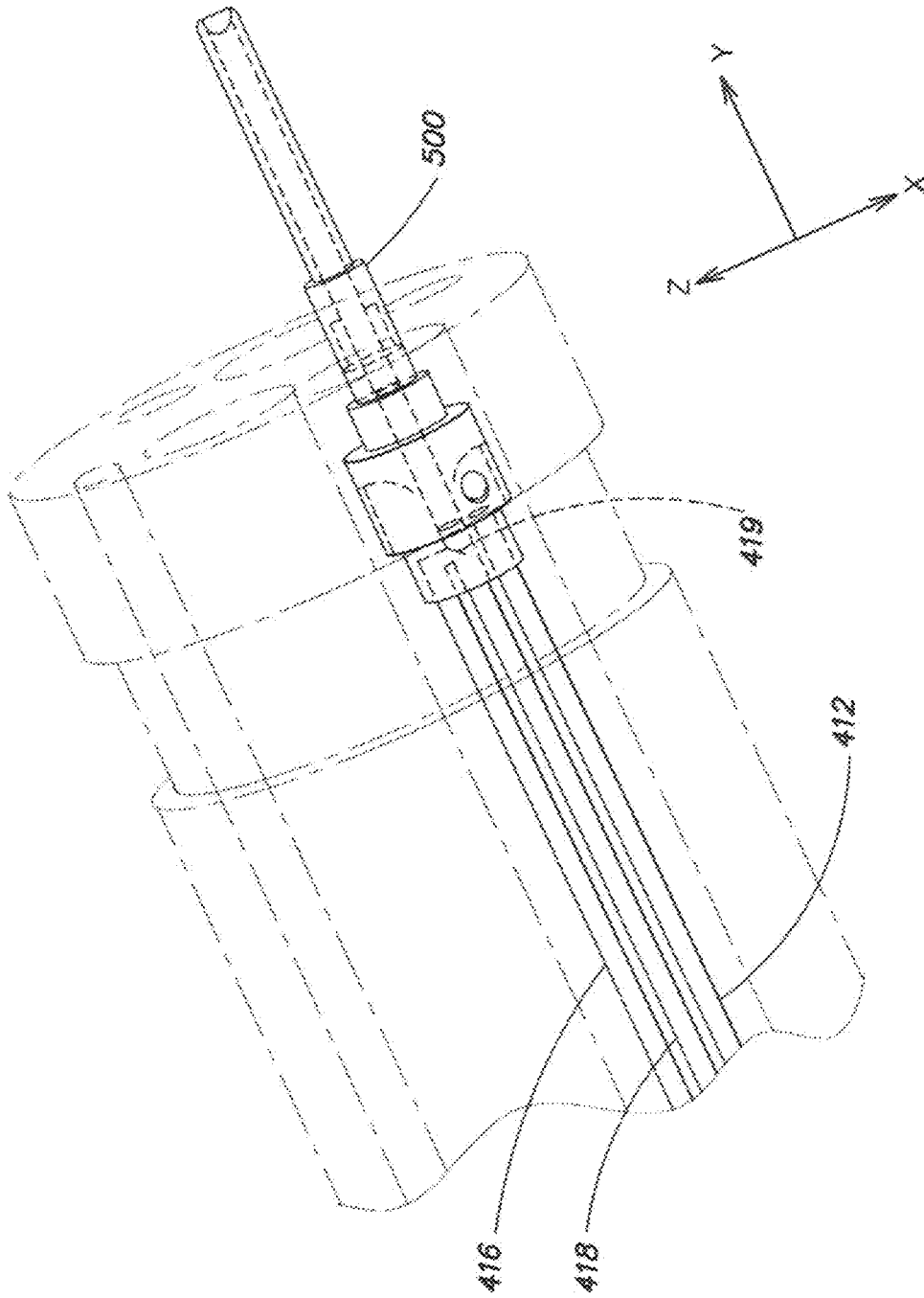

FIG. 13

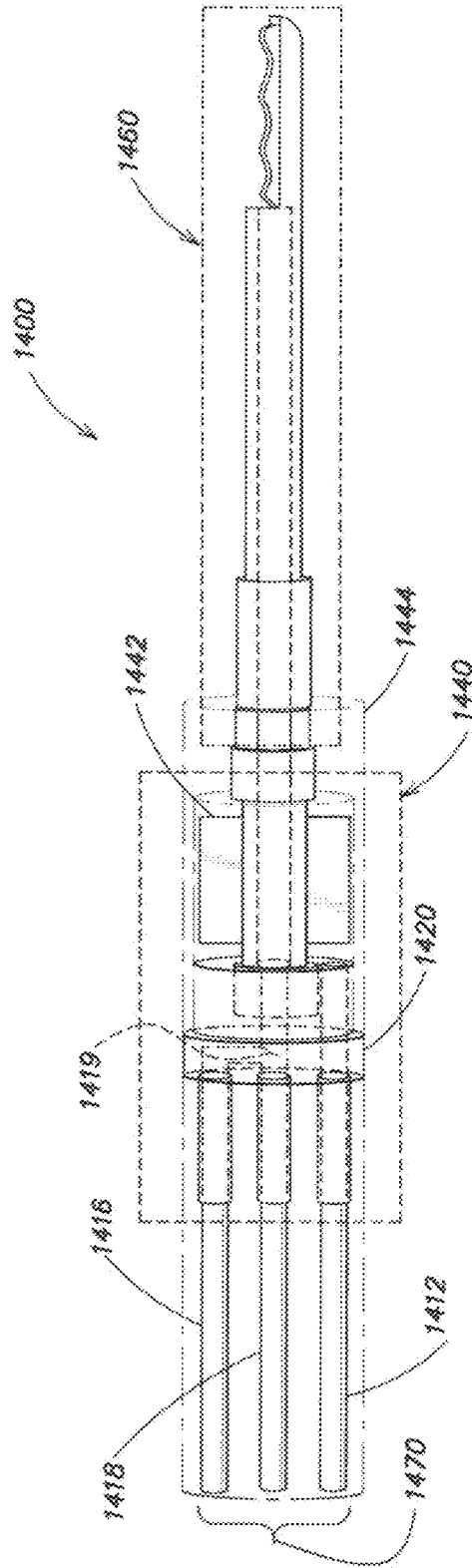

FIG. 14

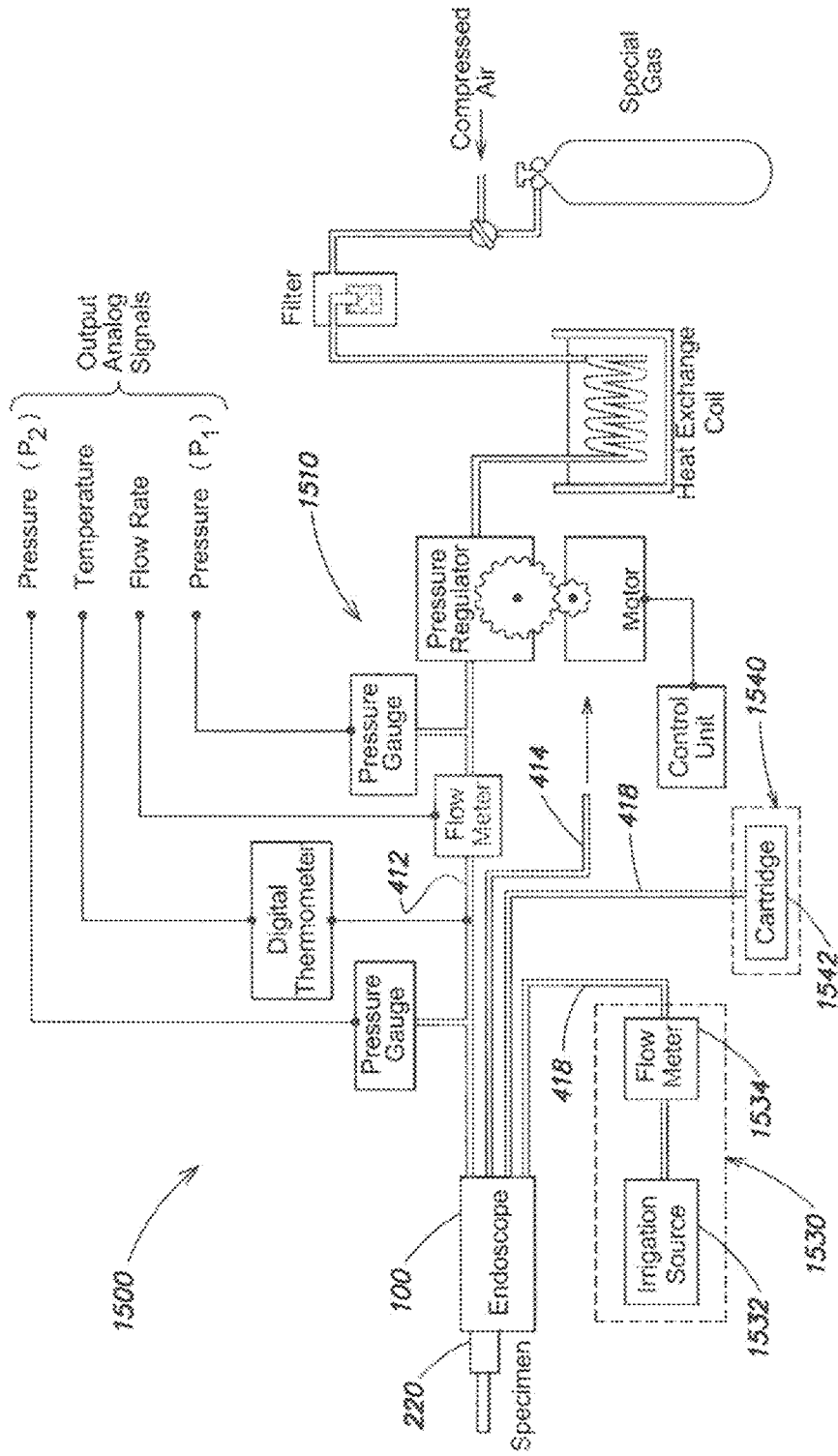

FIG. 15

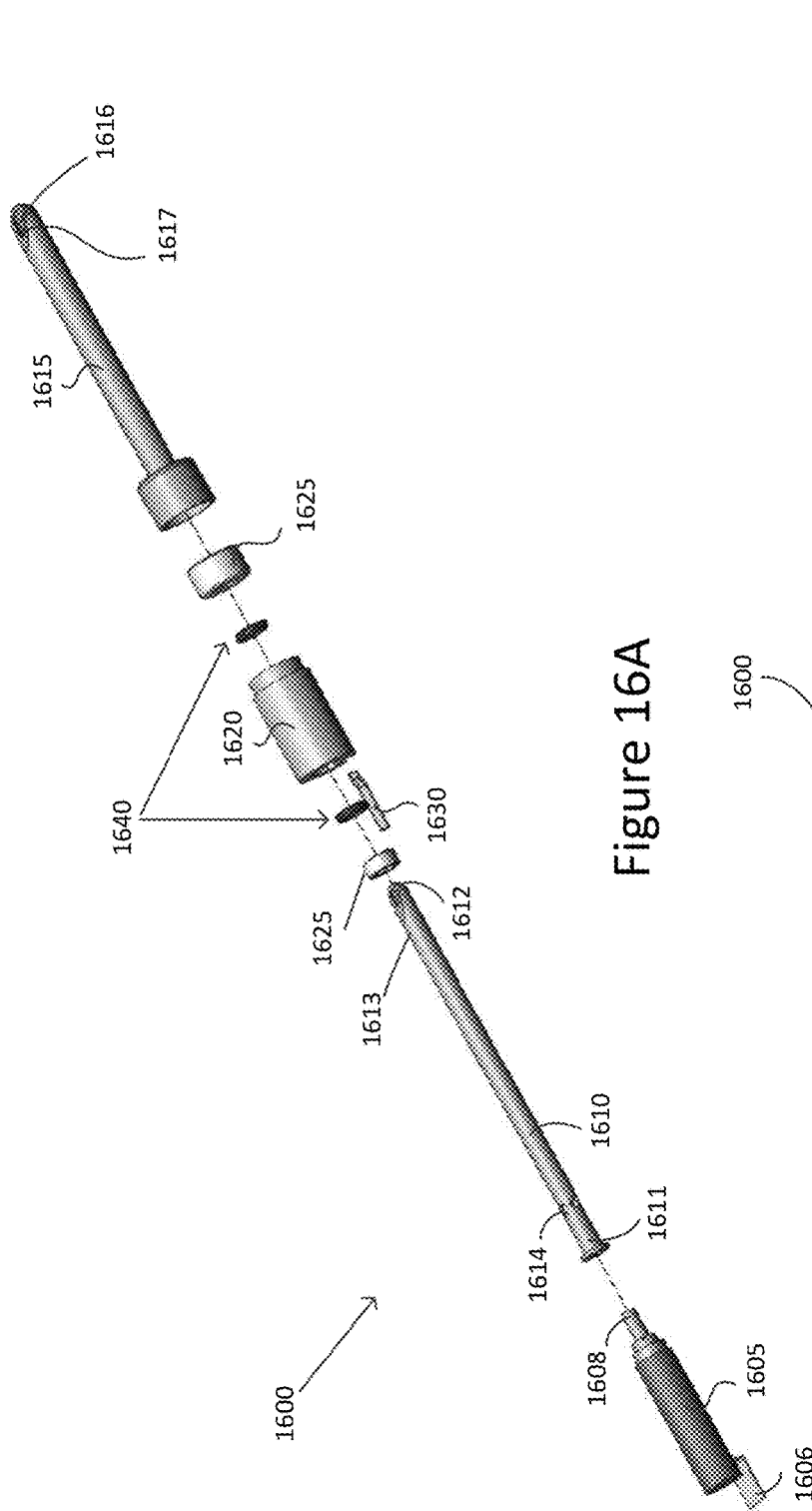

Figure 16A

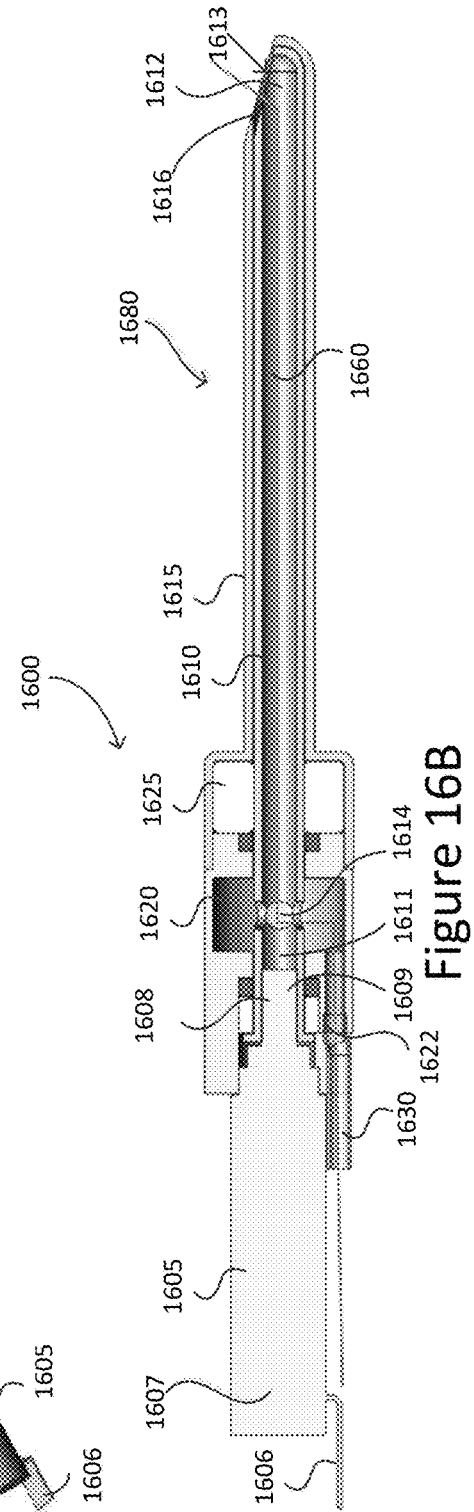
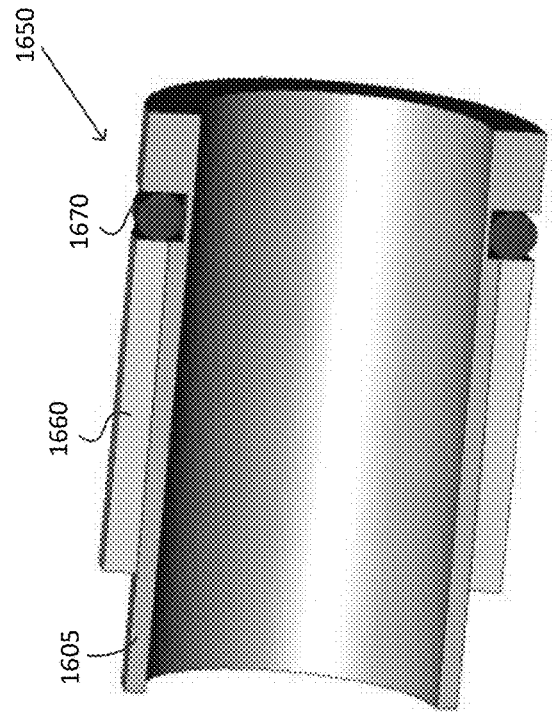
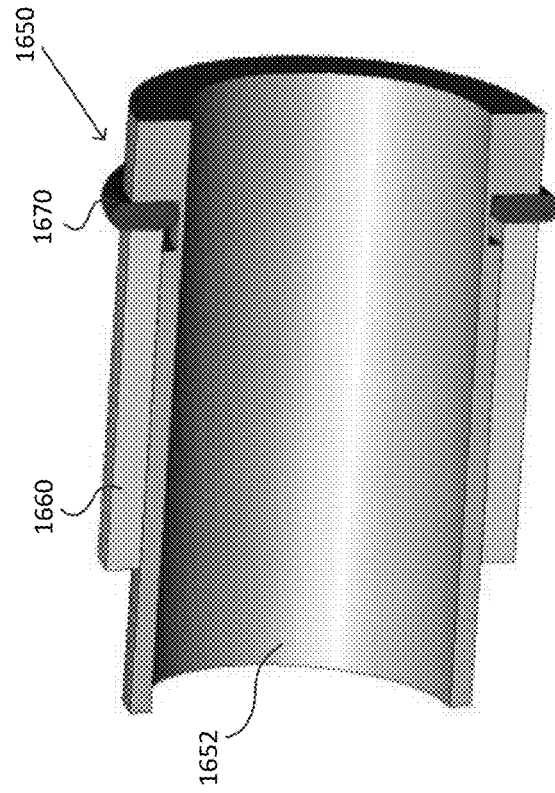
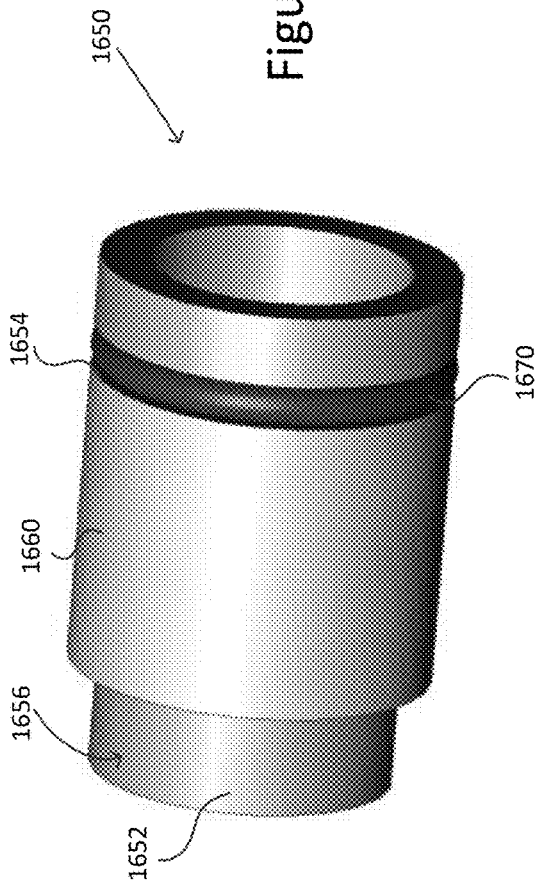

Figure 16B





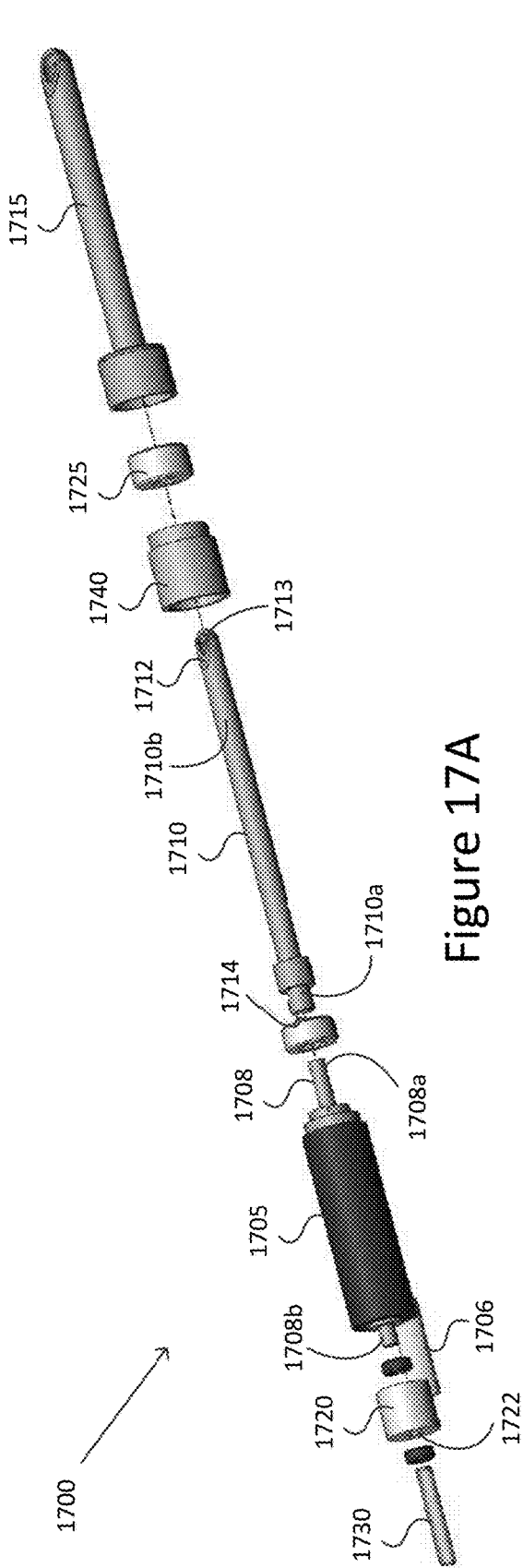

Figure 17A

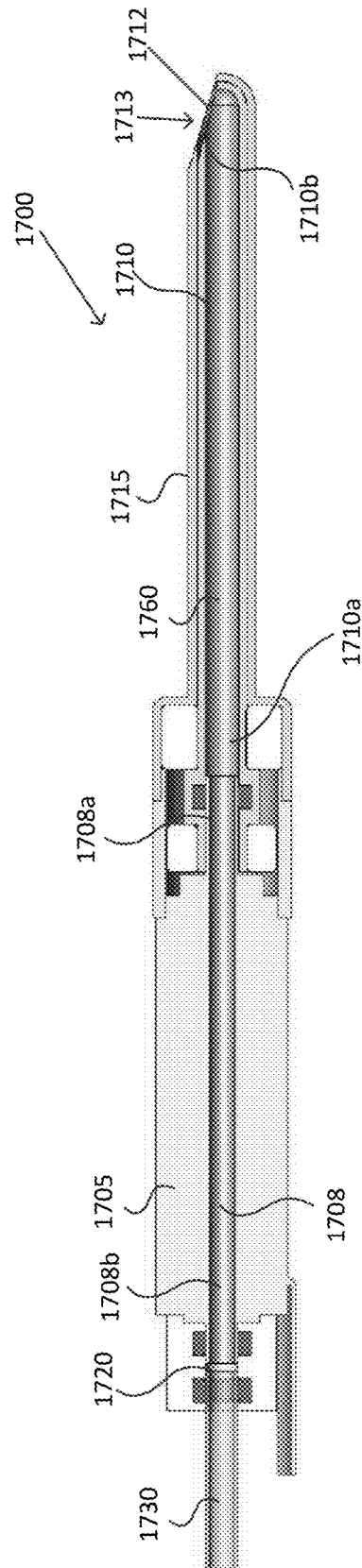

Figure 17B

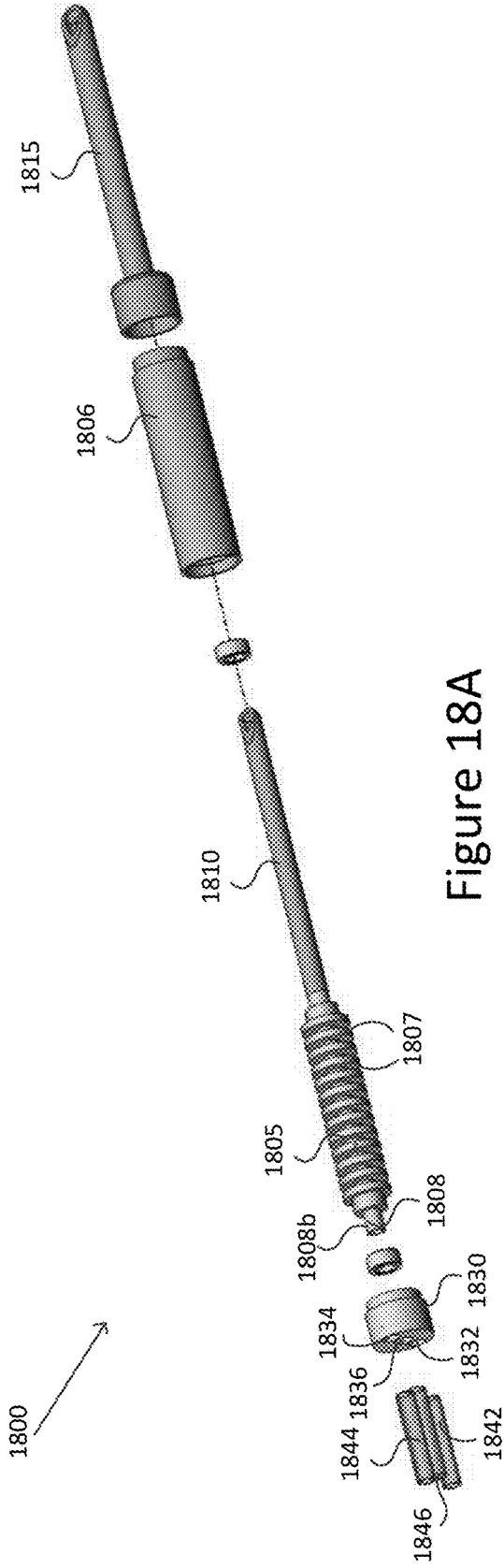

Figure 18A

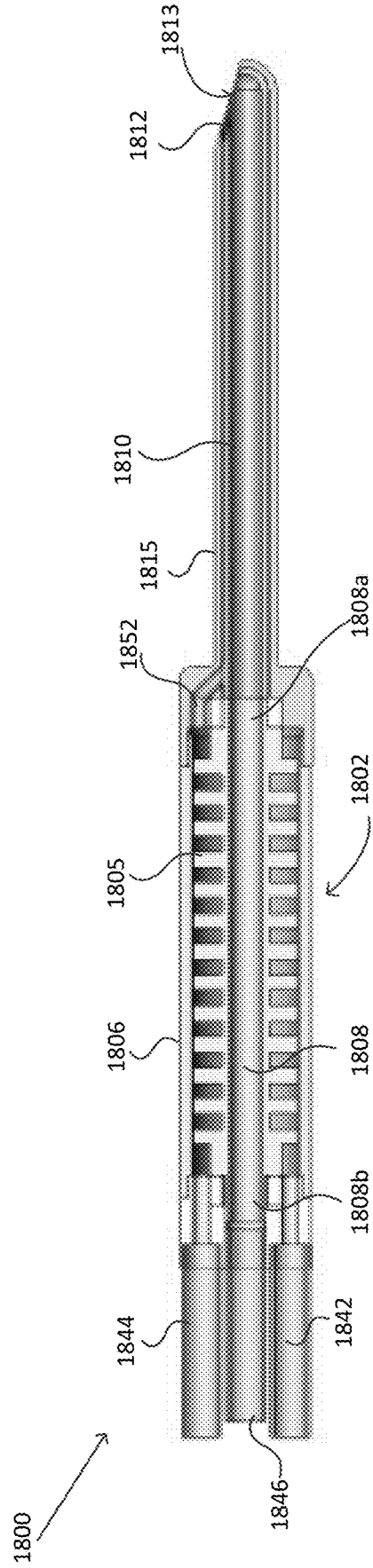

Figure 18B

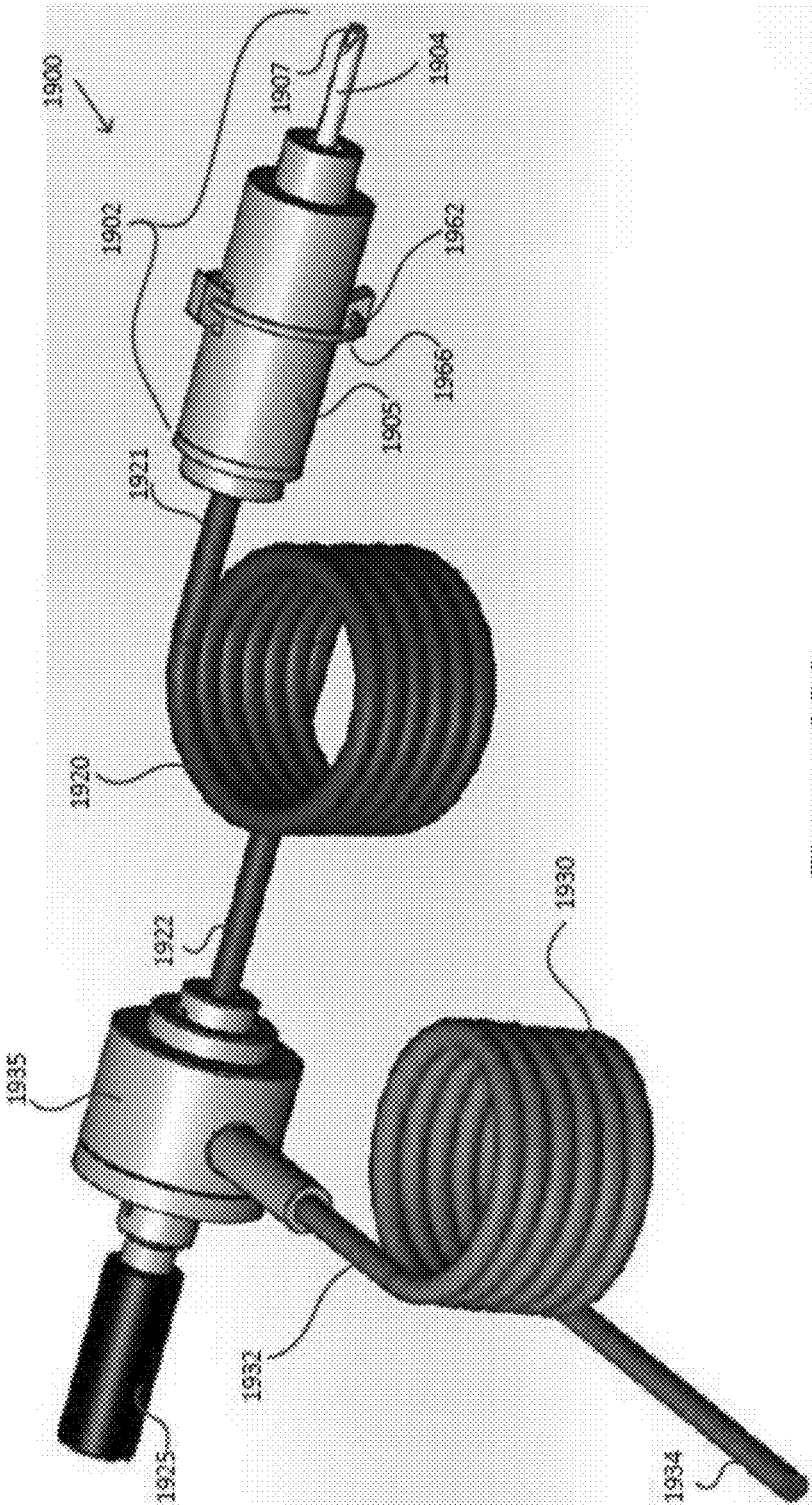

Figure 19A

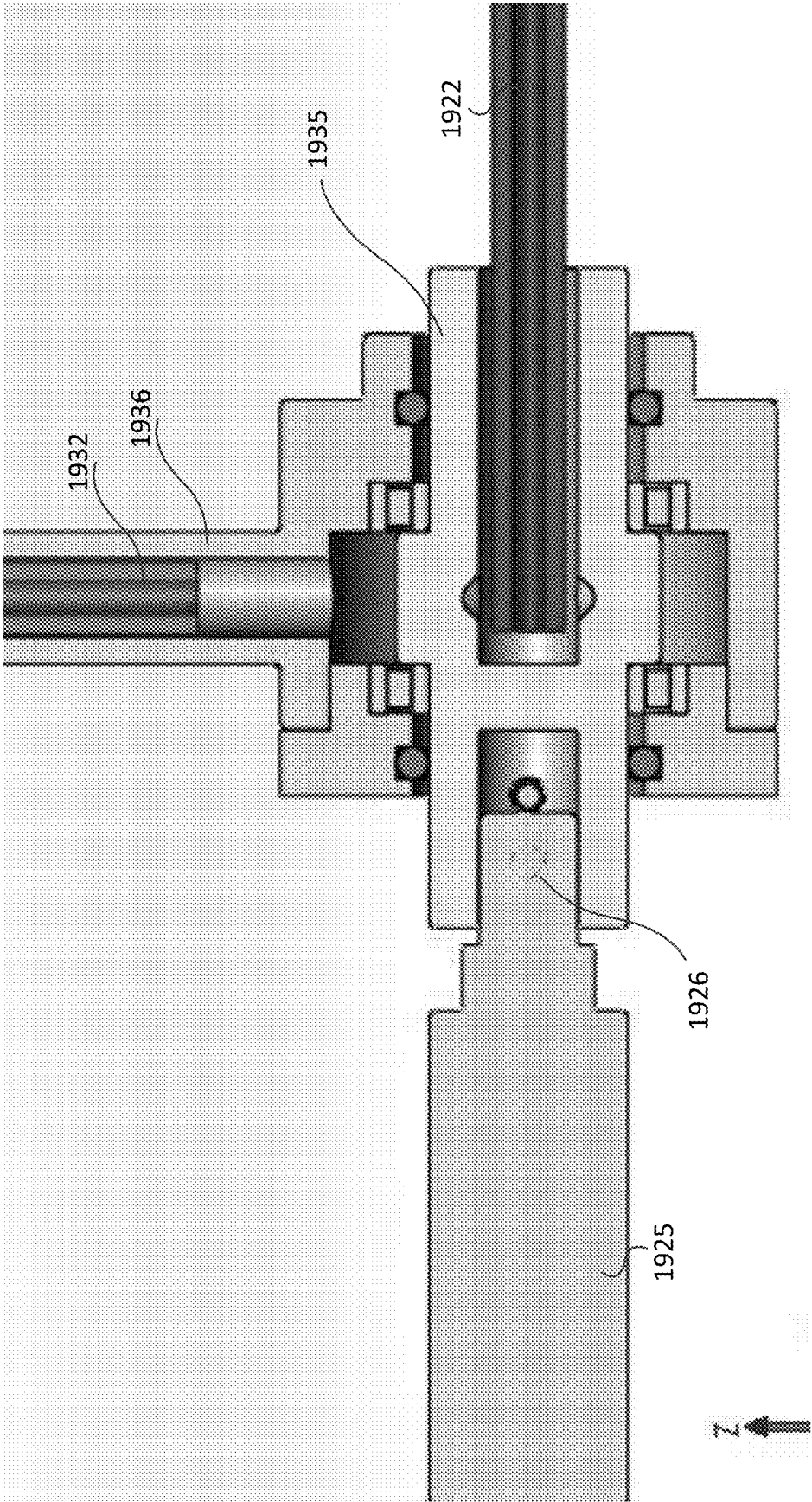

Figure 19B

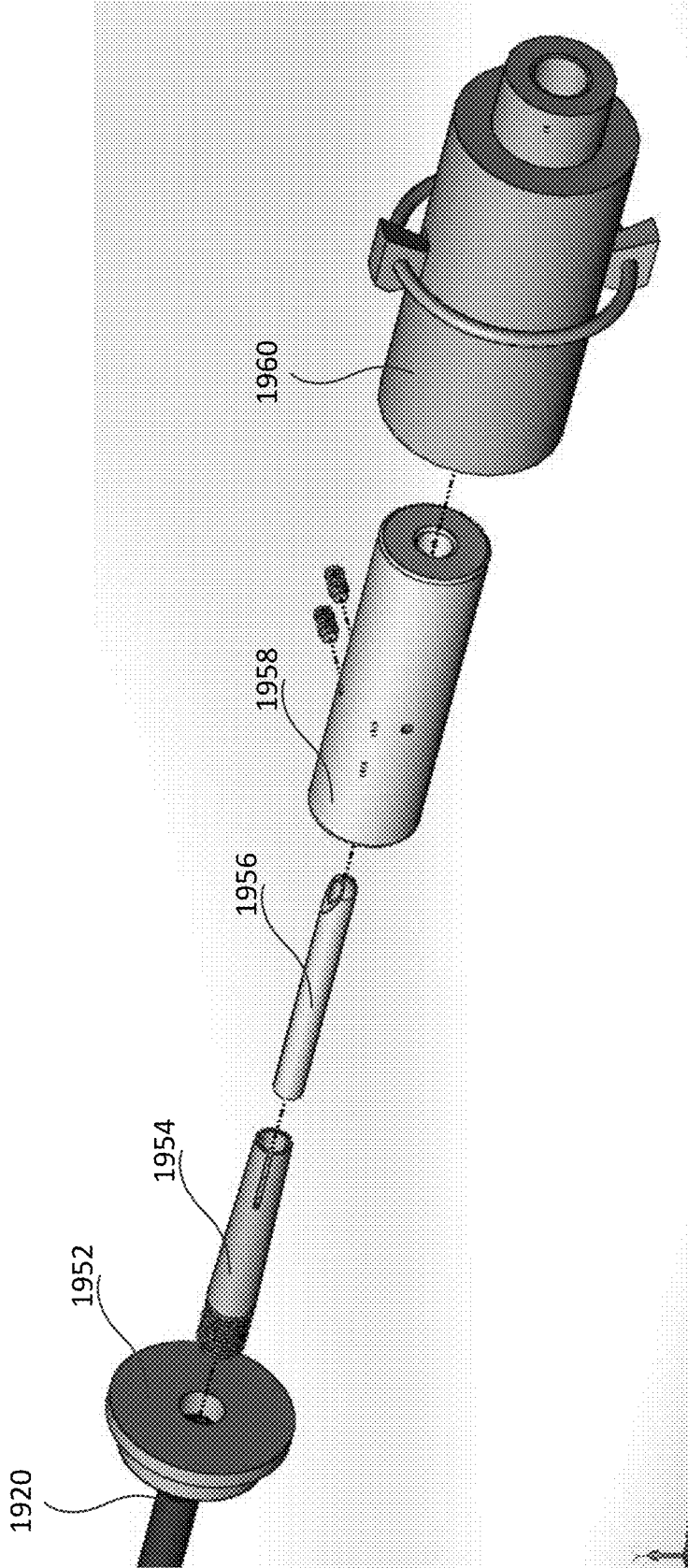

Figure 19C

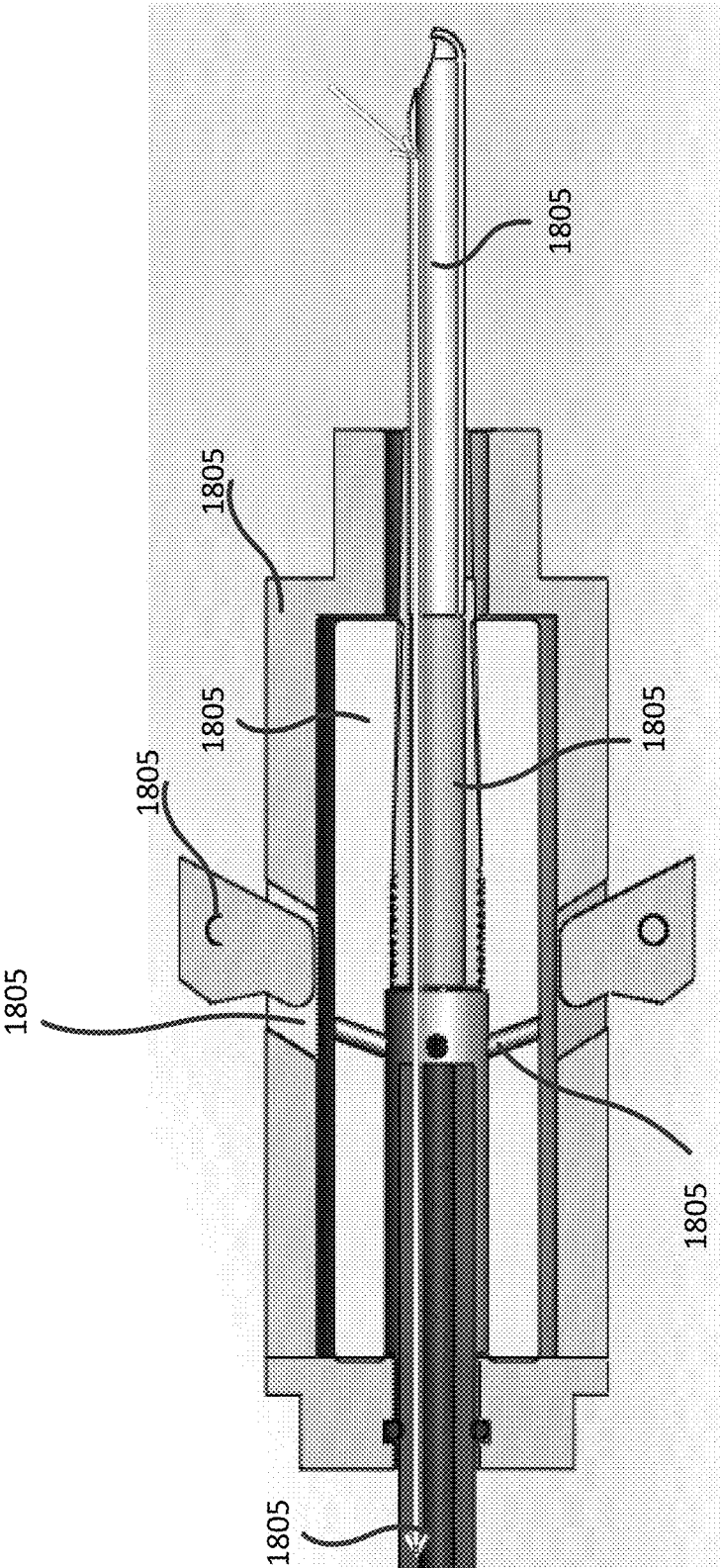
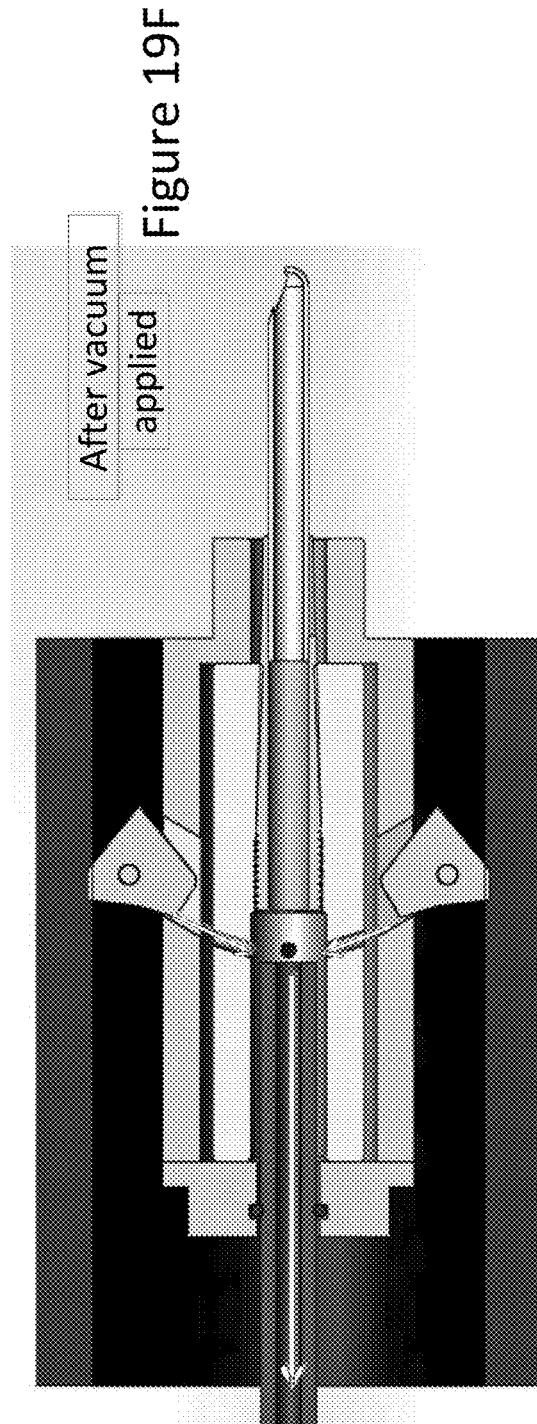
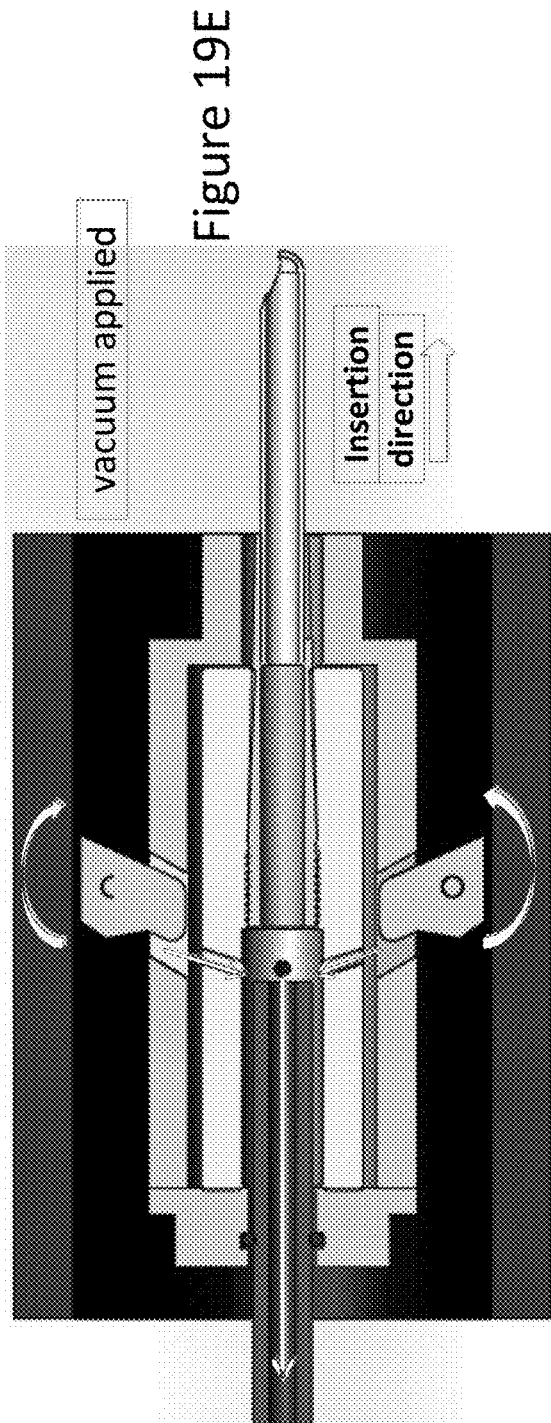

Figure 19D



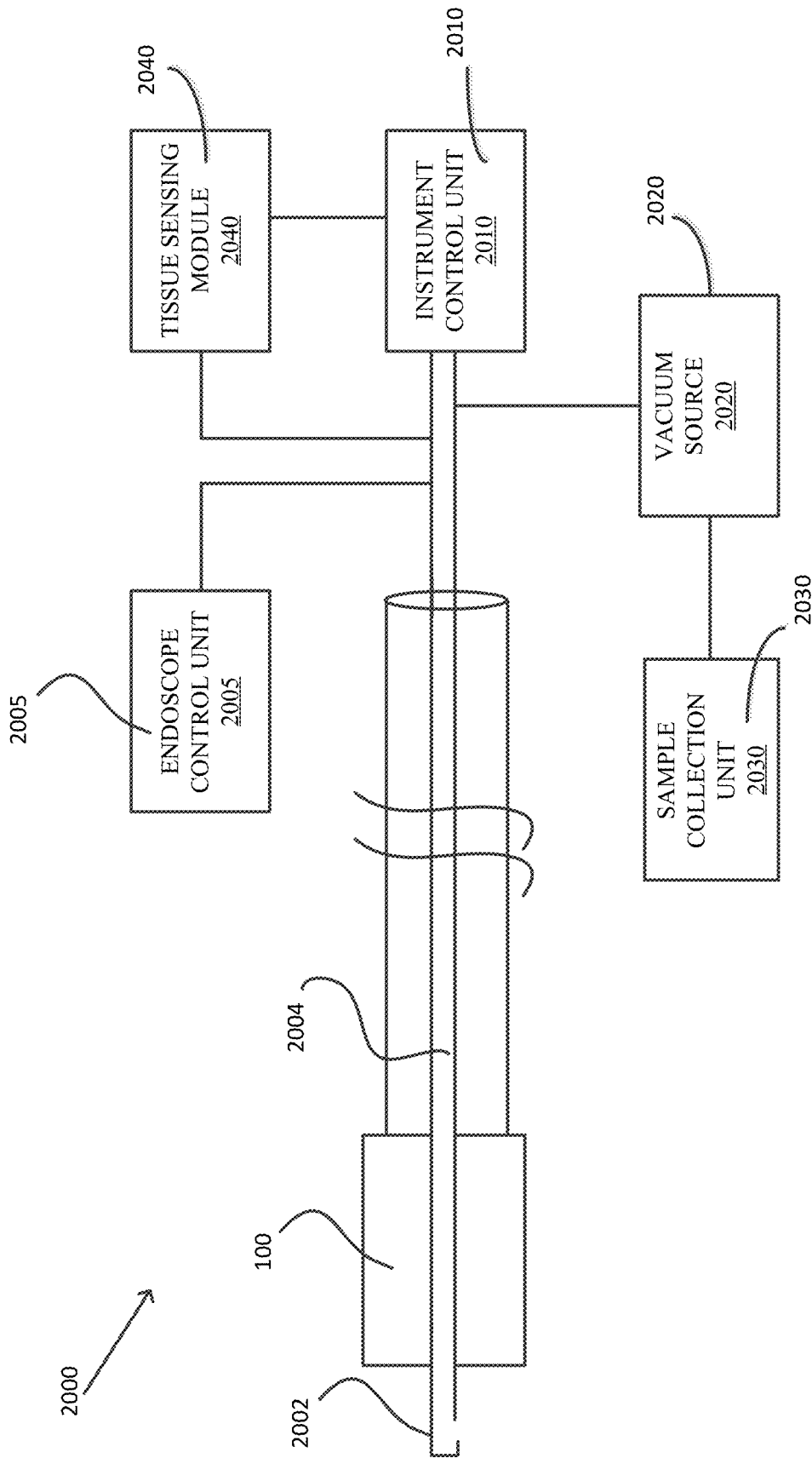

Figure 20



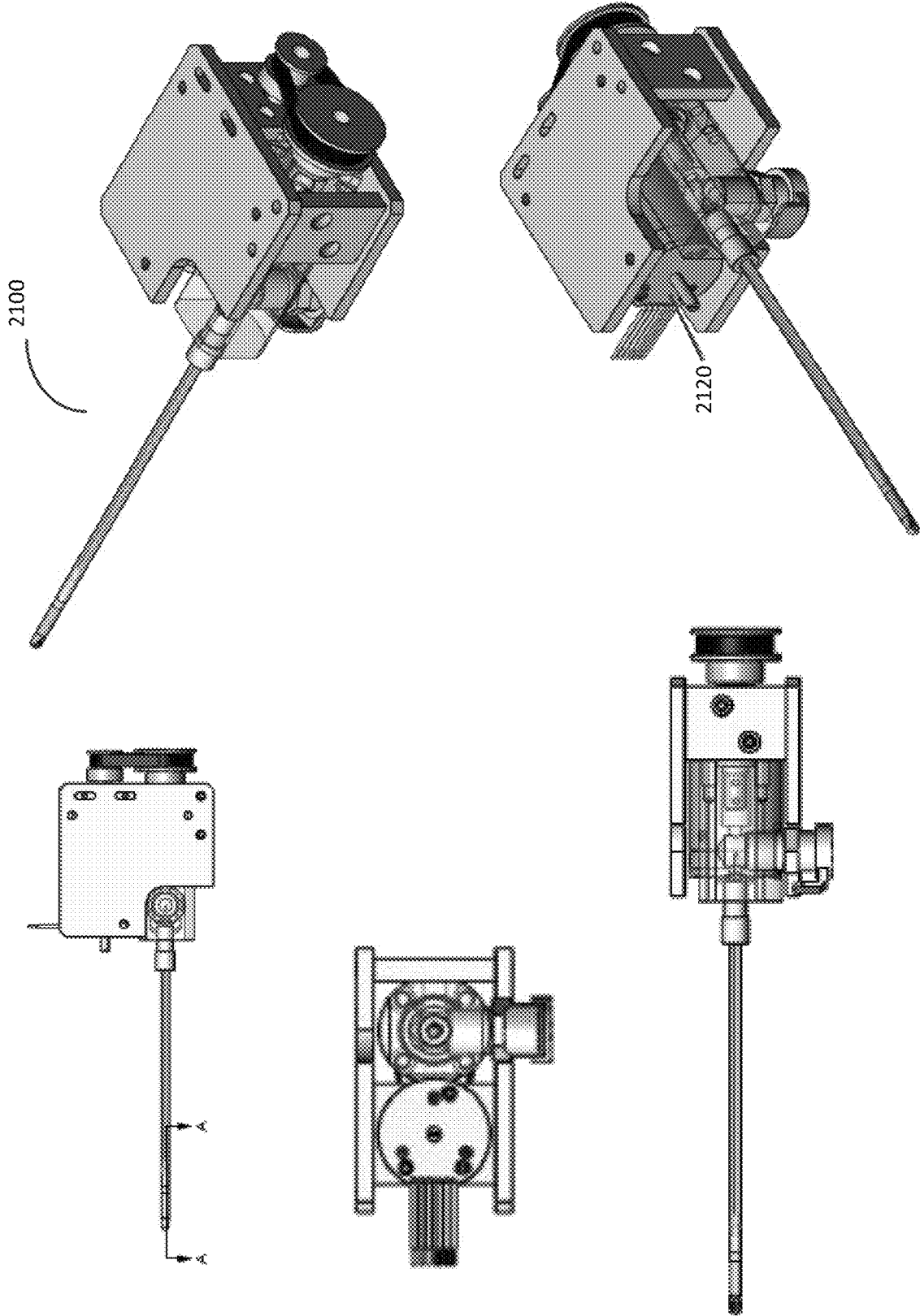

Figure 21A

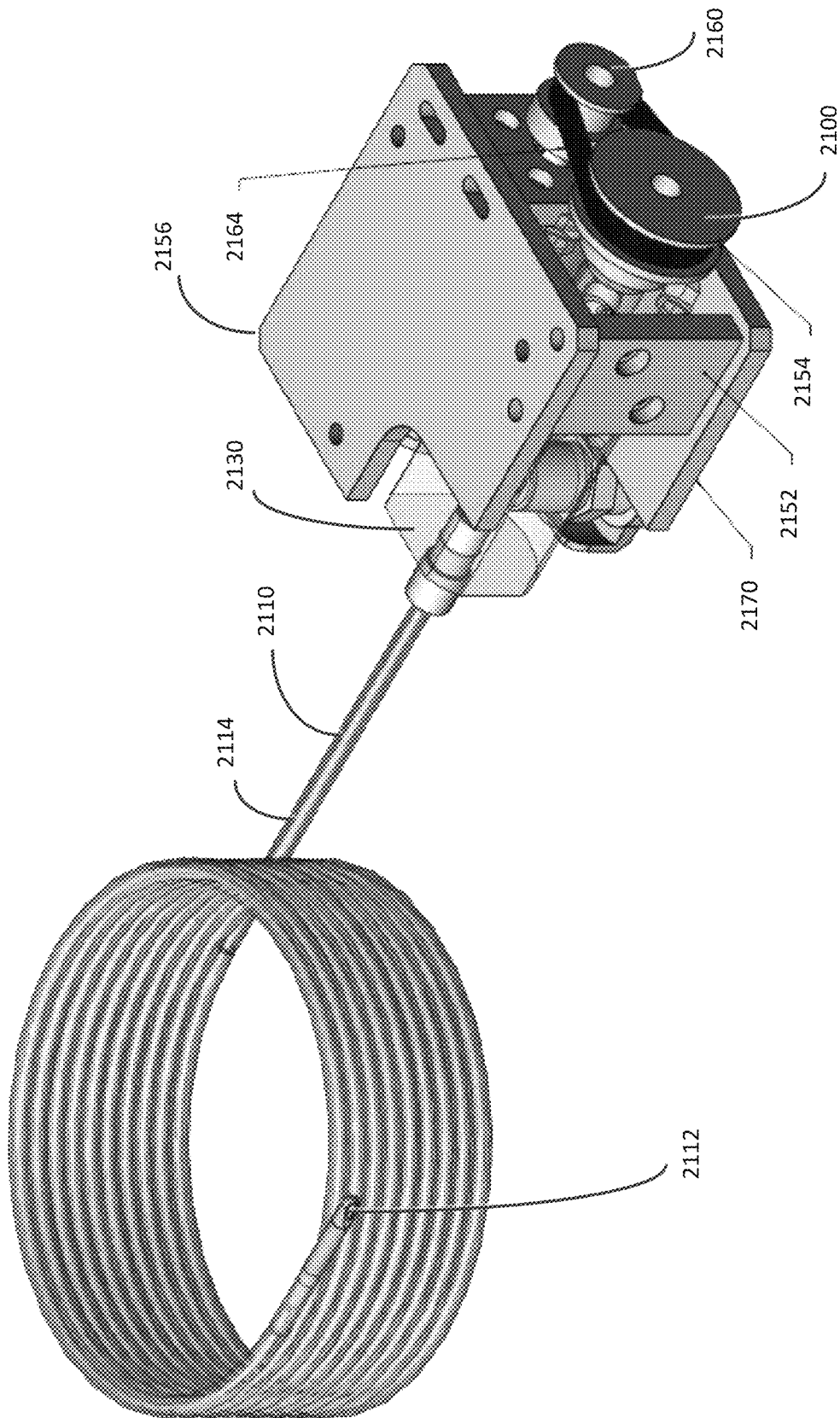

Figure 21B

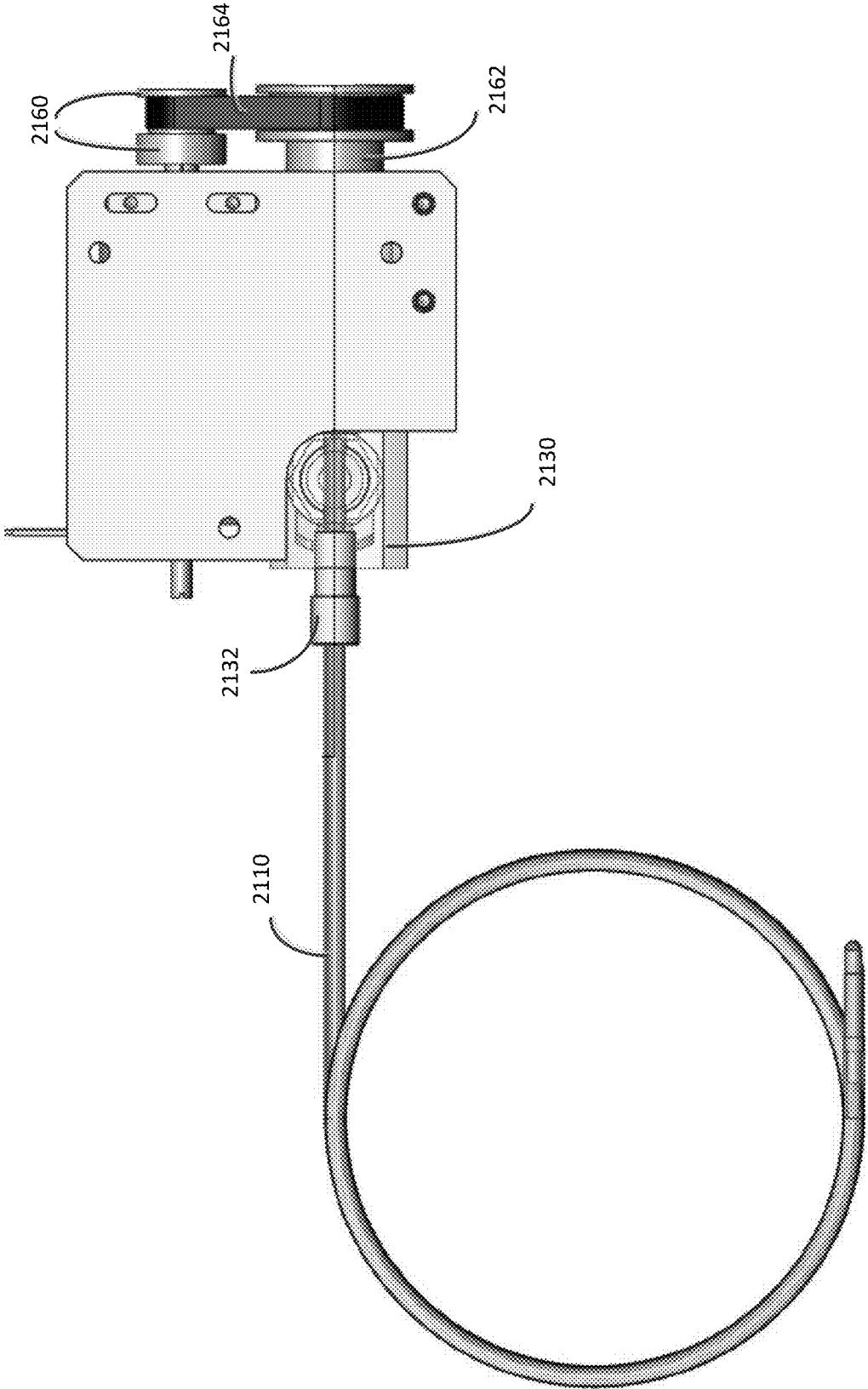

Figure 21C

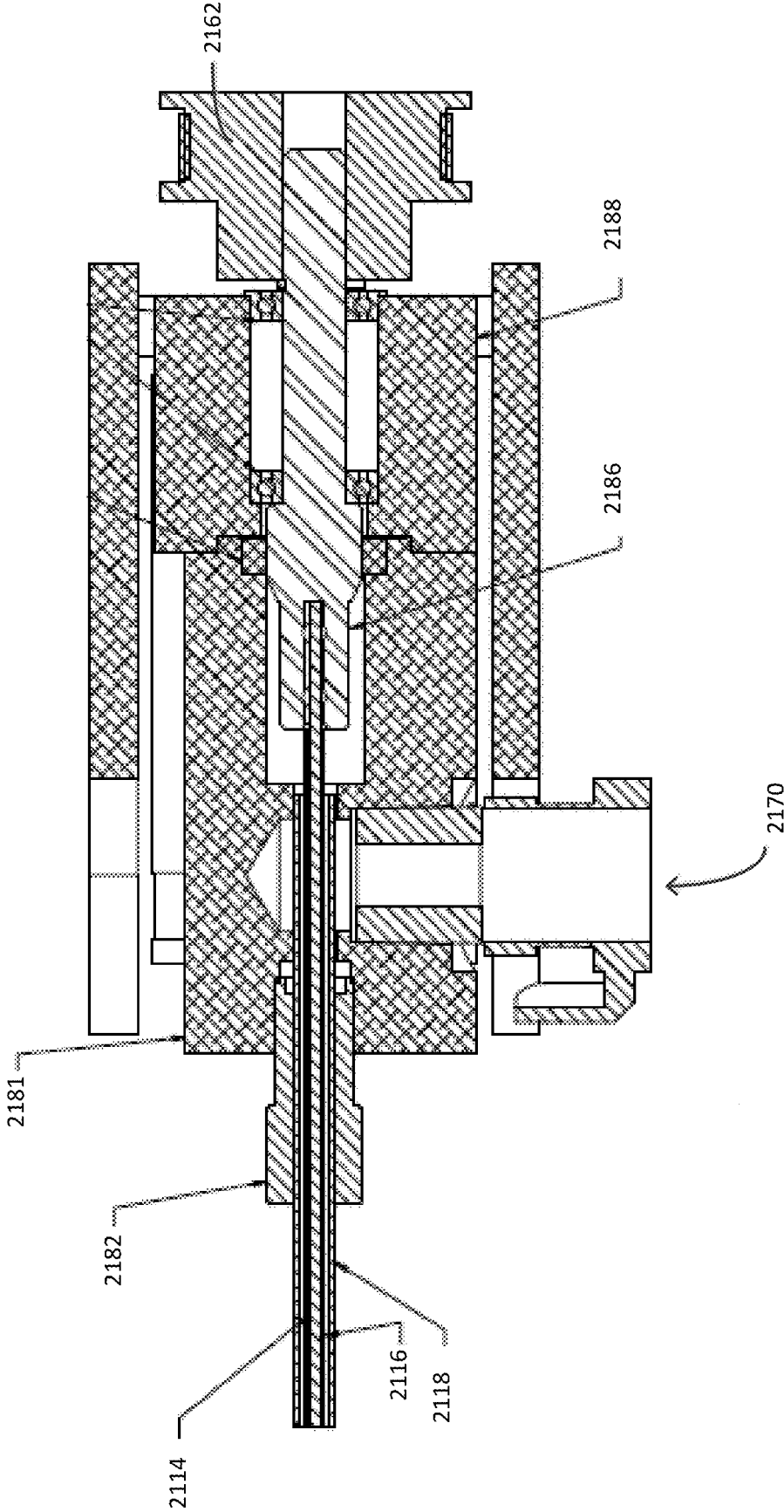

Figure 21D

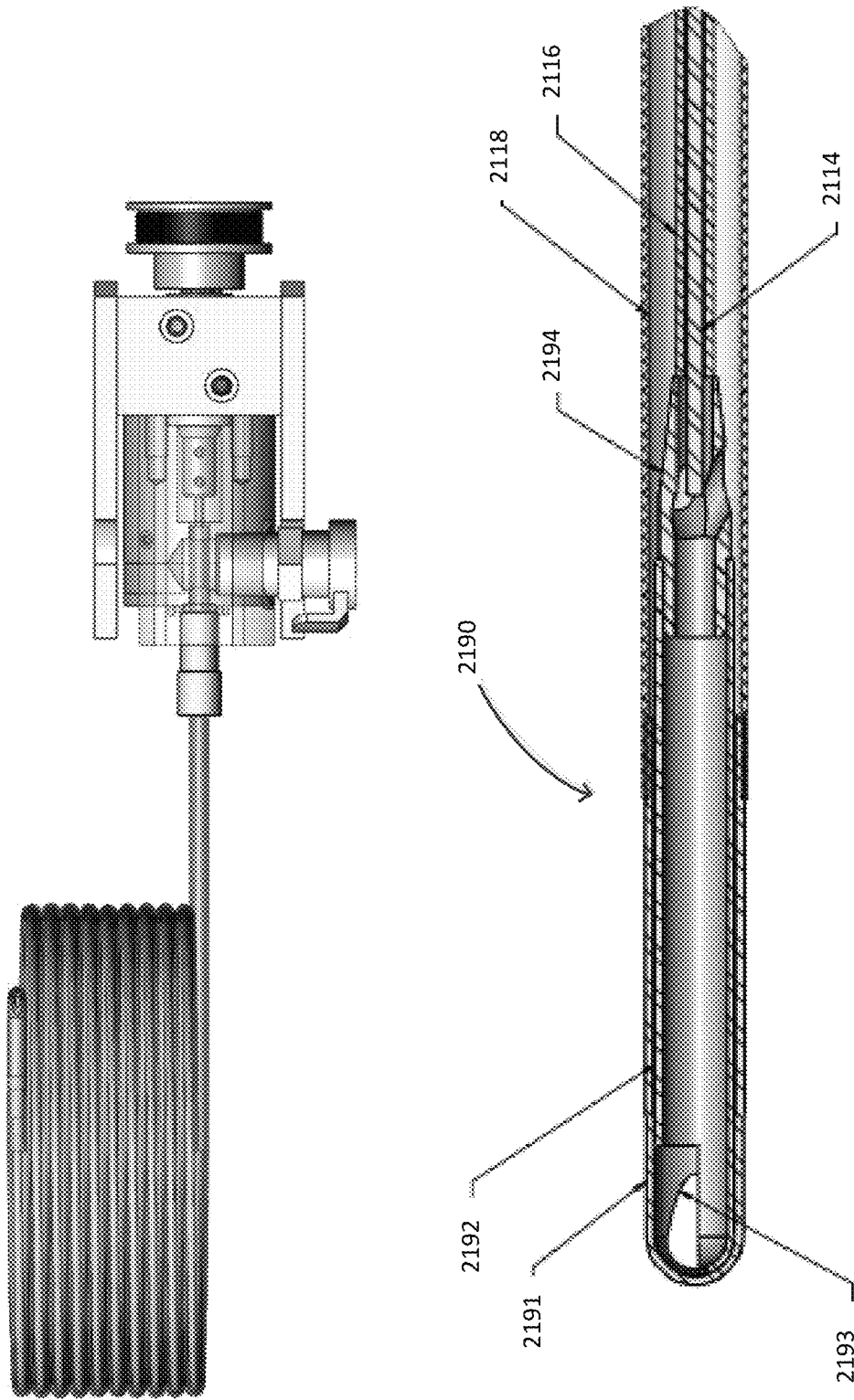

Figure 21E

Figure 22B

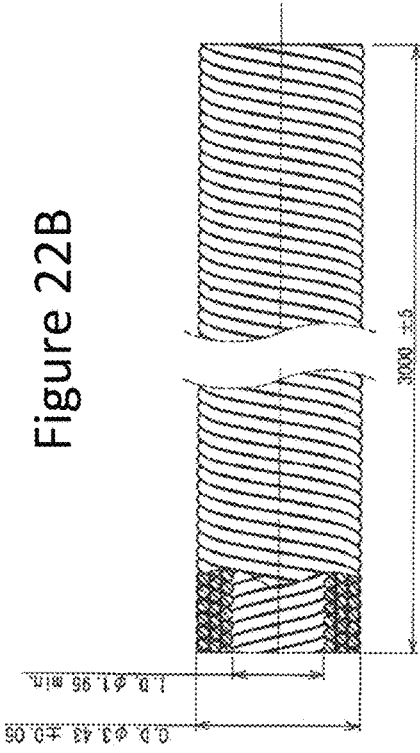

Figure 22D

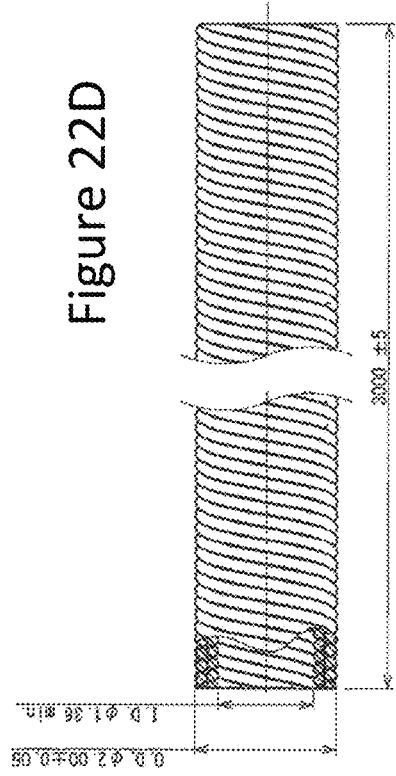

Figure 22A

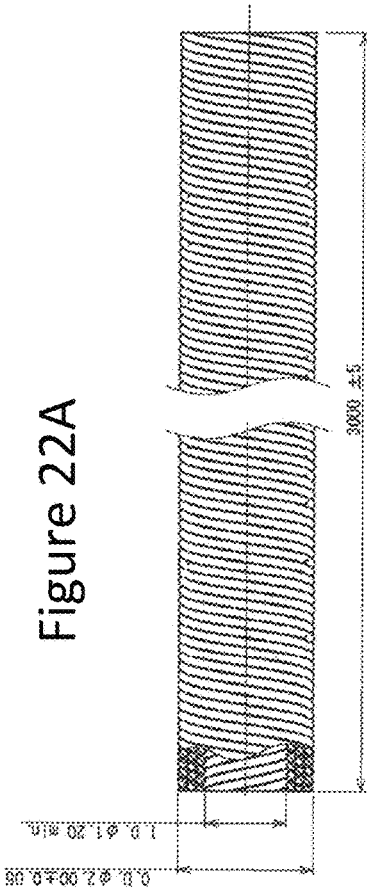
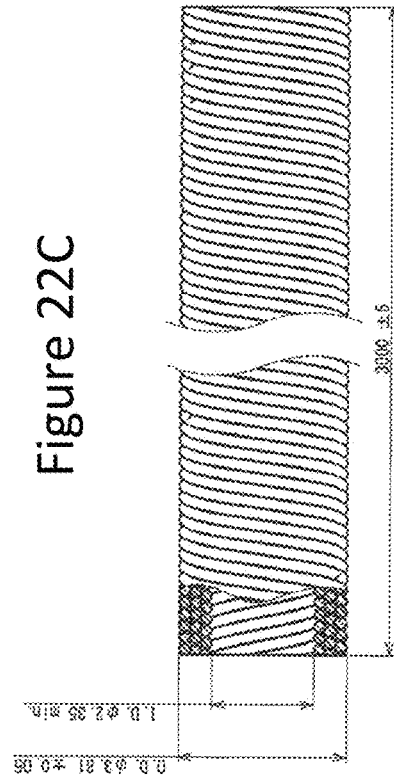

Figure 22C



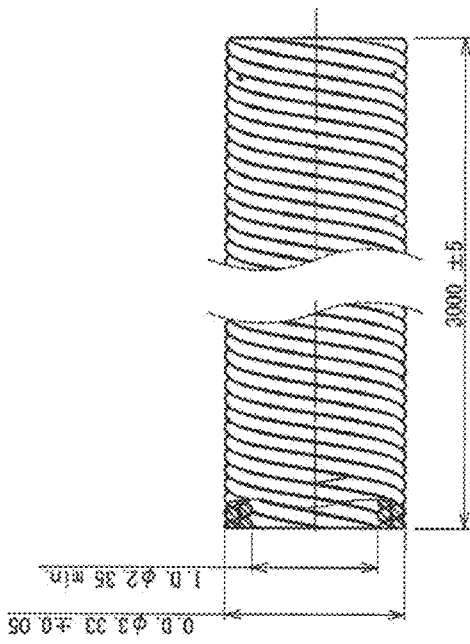

Figure 22E

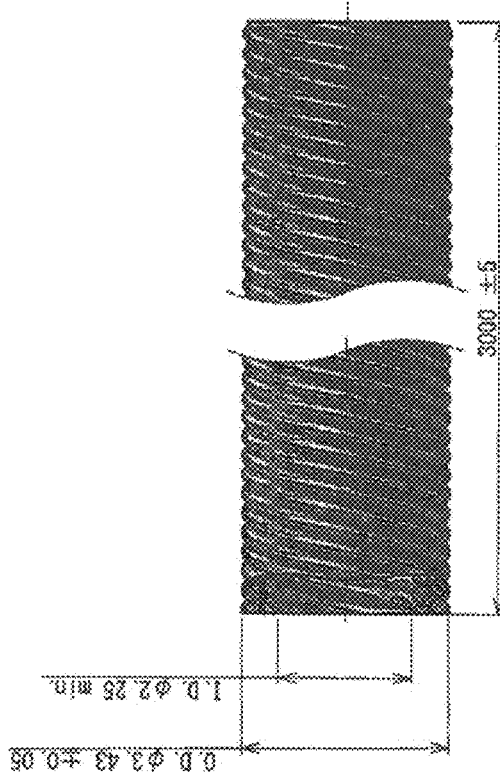

Figure 22F

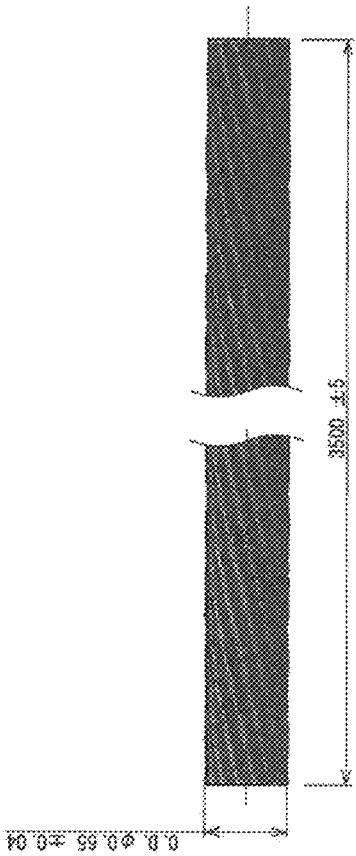

Figure 22G

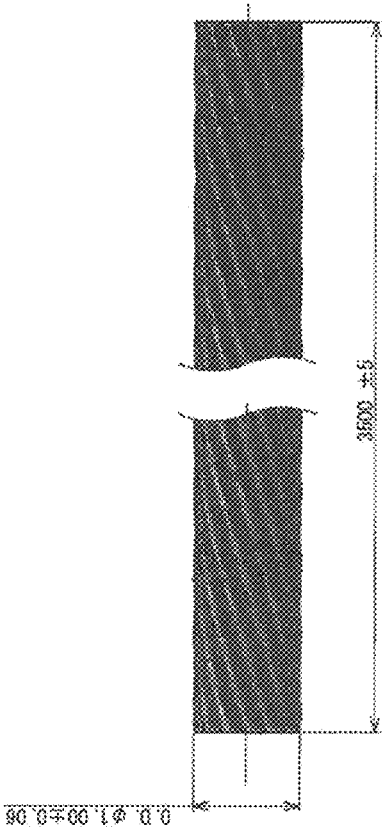

Figure 22H



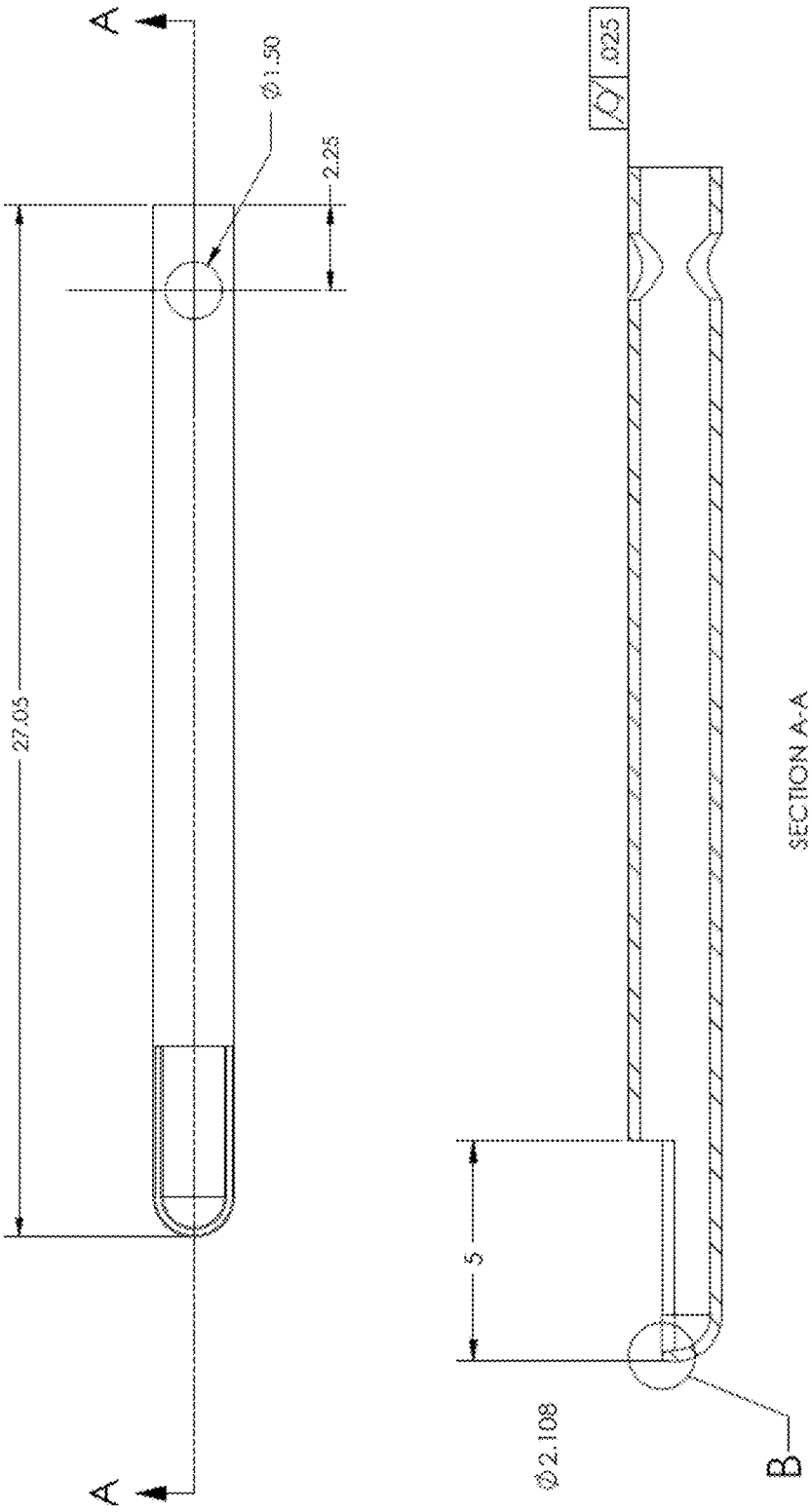

Figure 23A

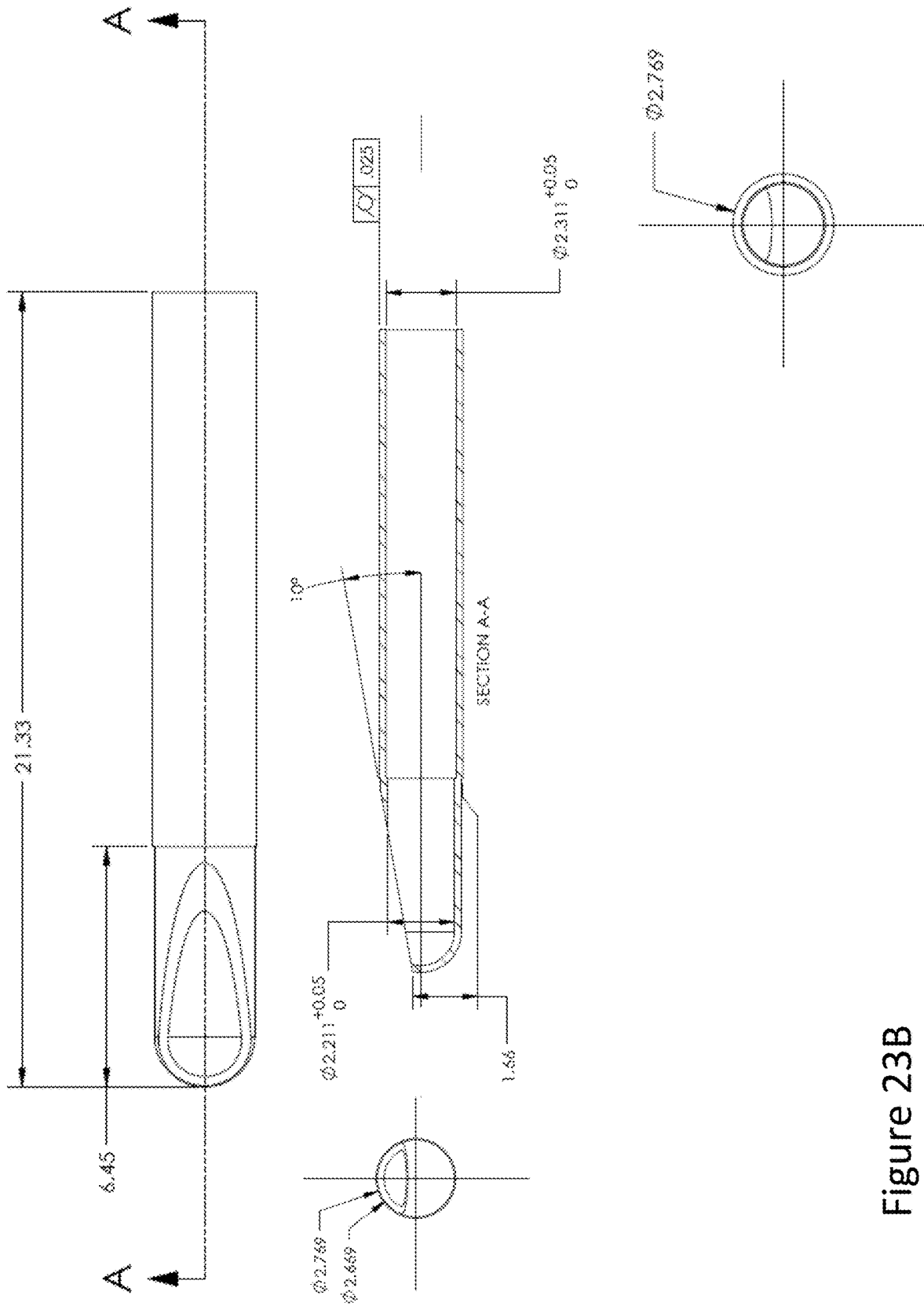

Figure 23B

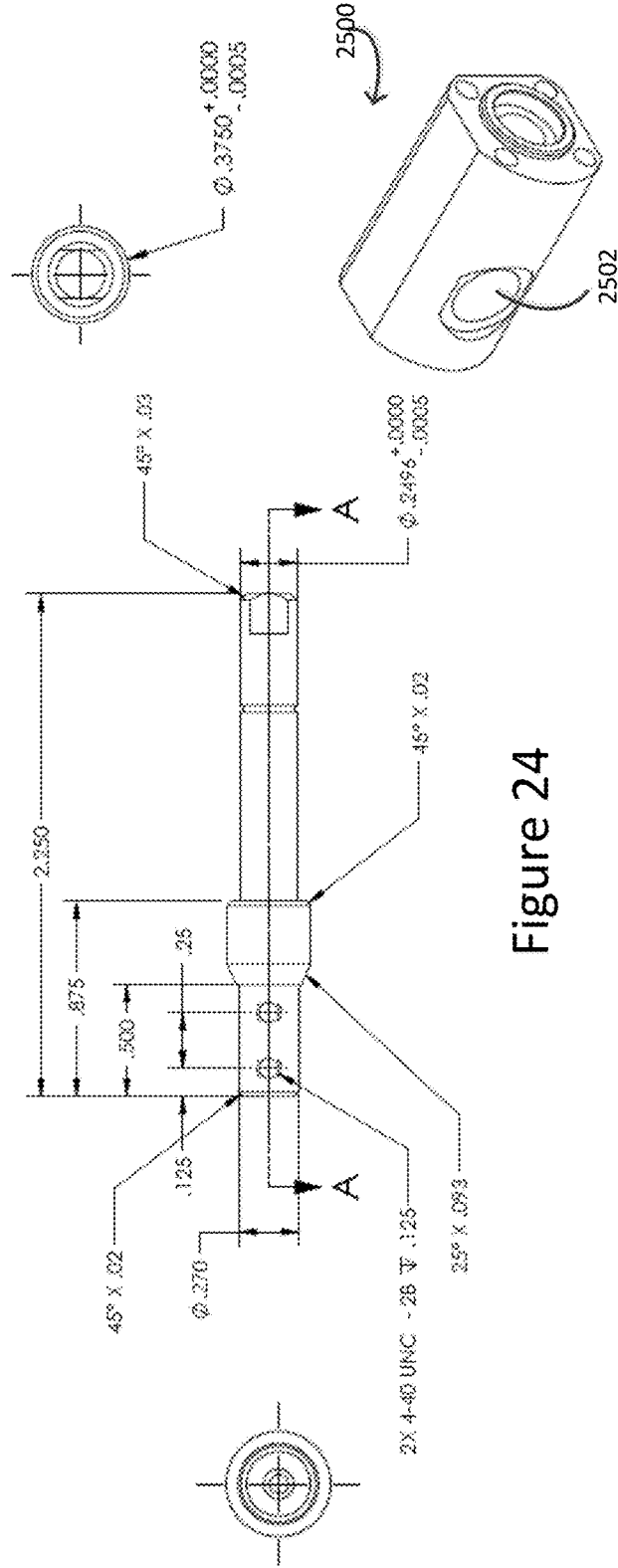
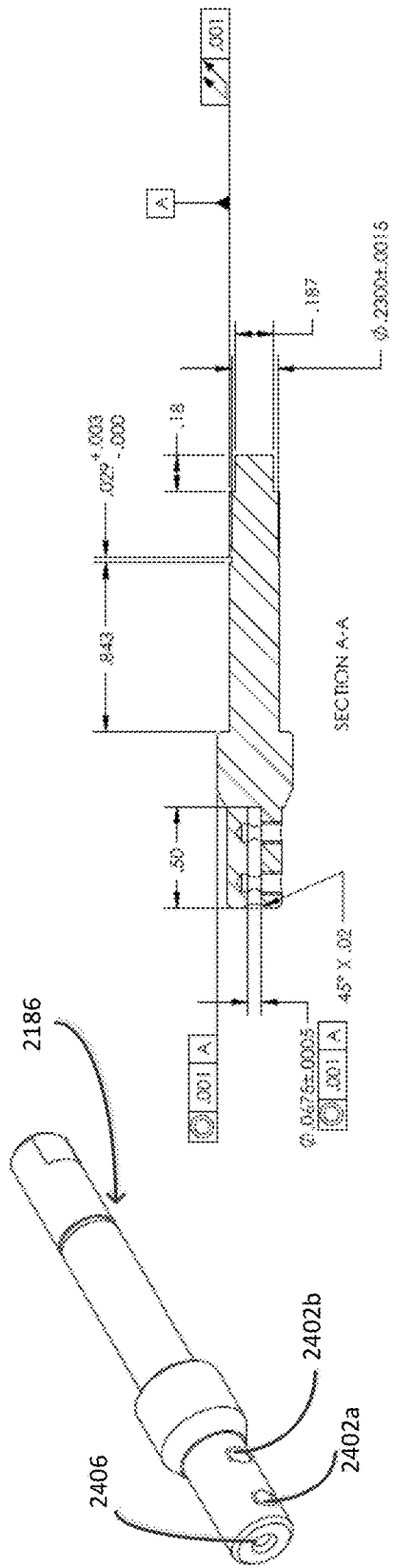

Figure 24

Figure 25

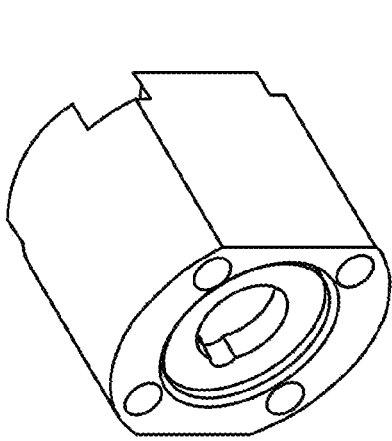

FIG. 26A

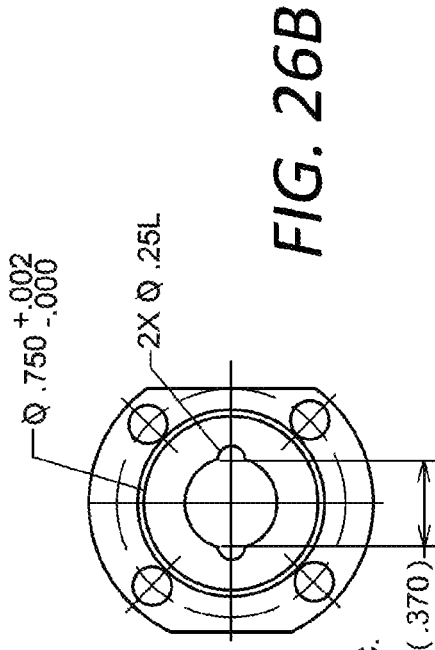

FIG. 26B

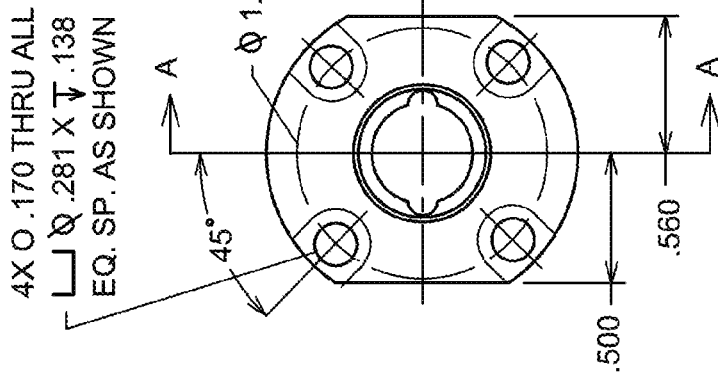

FIG. 26D

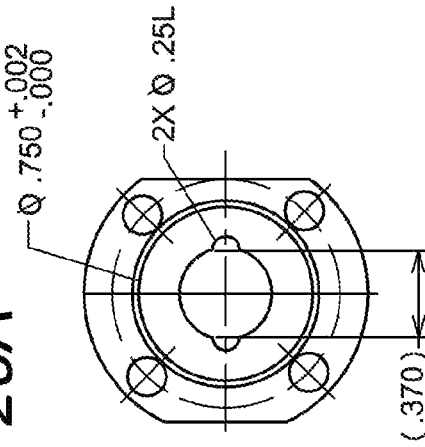

FIG. 26C

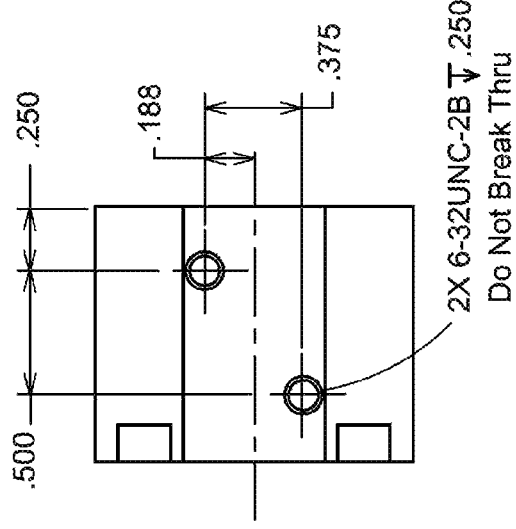

FIG. 26E

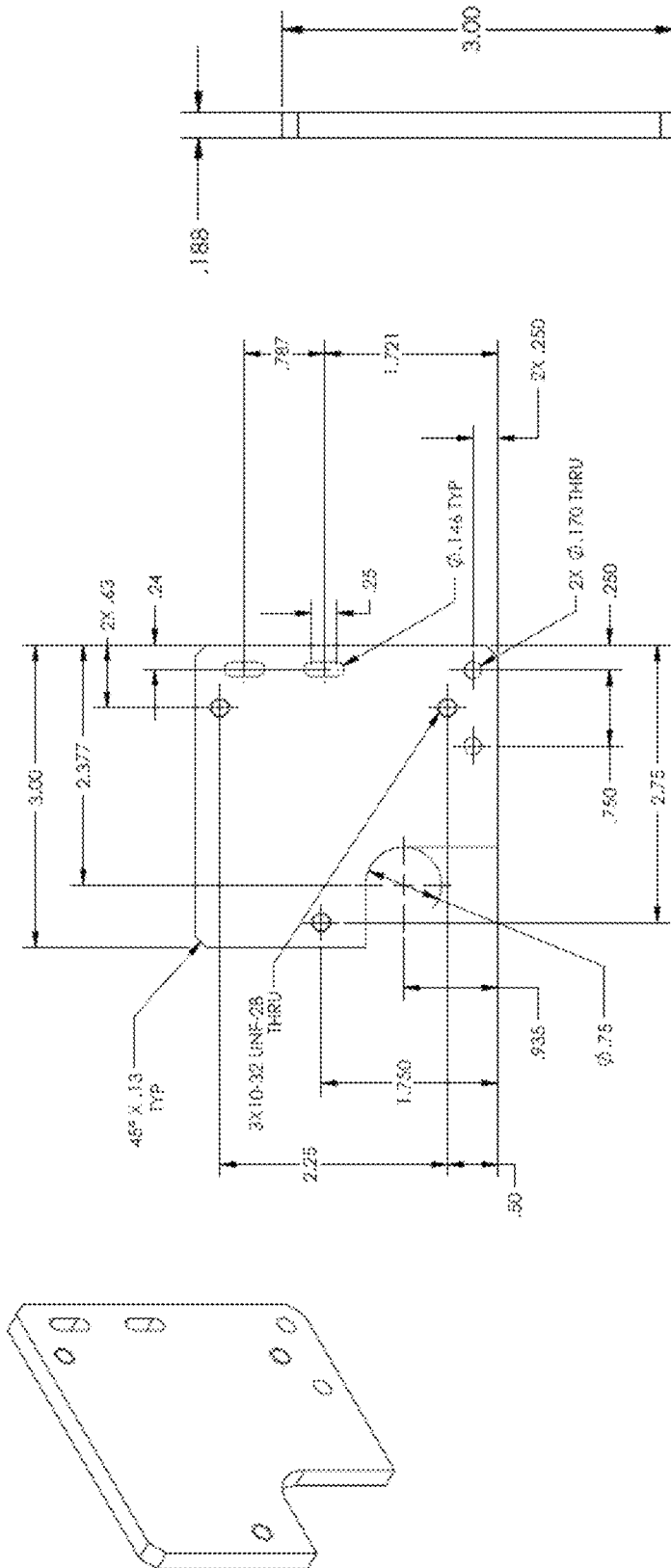

Figure 27

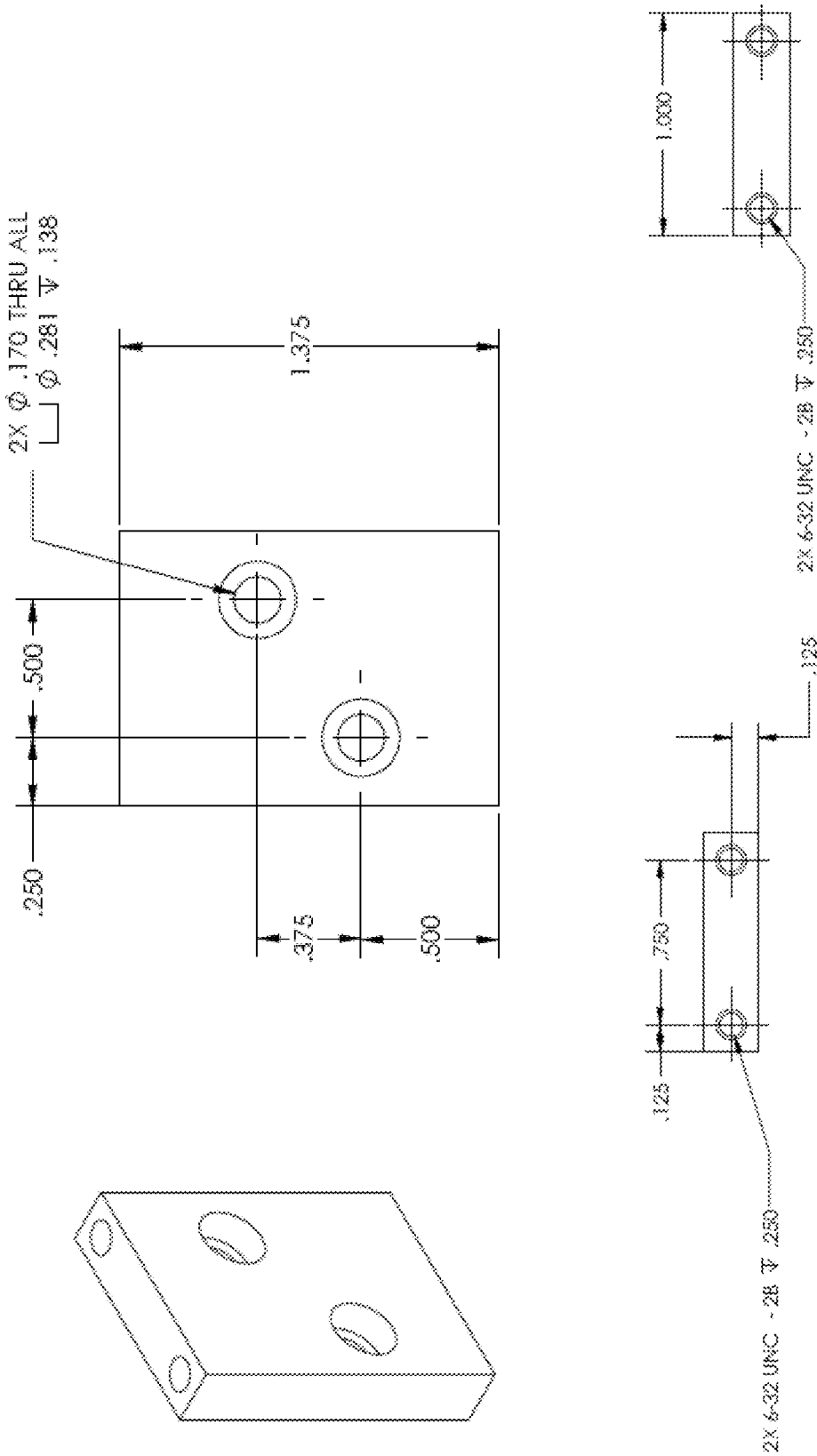

Figure 28

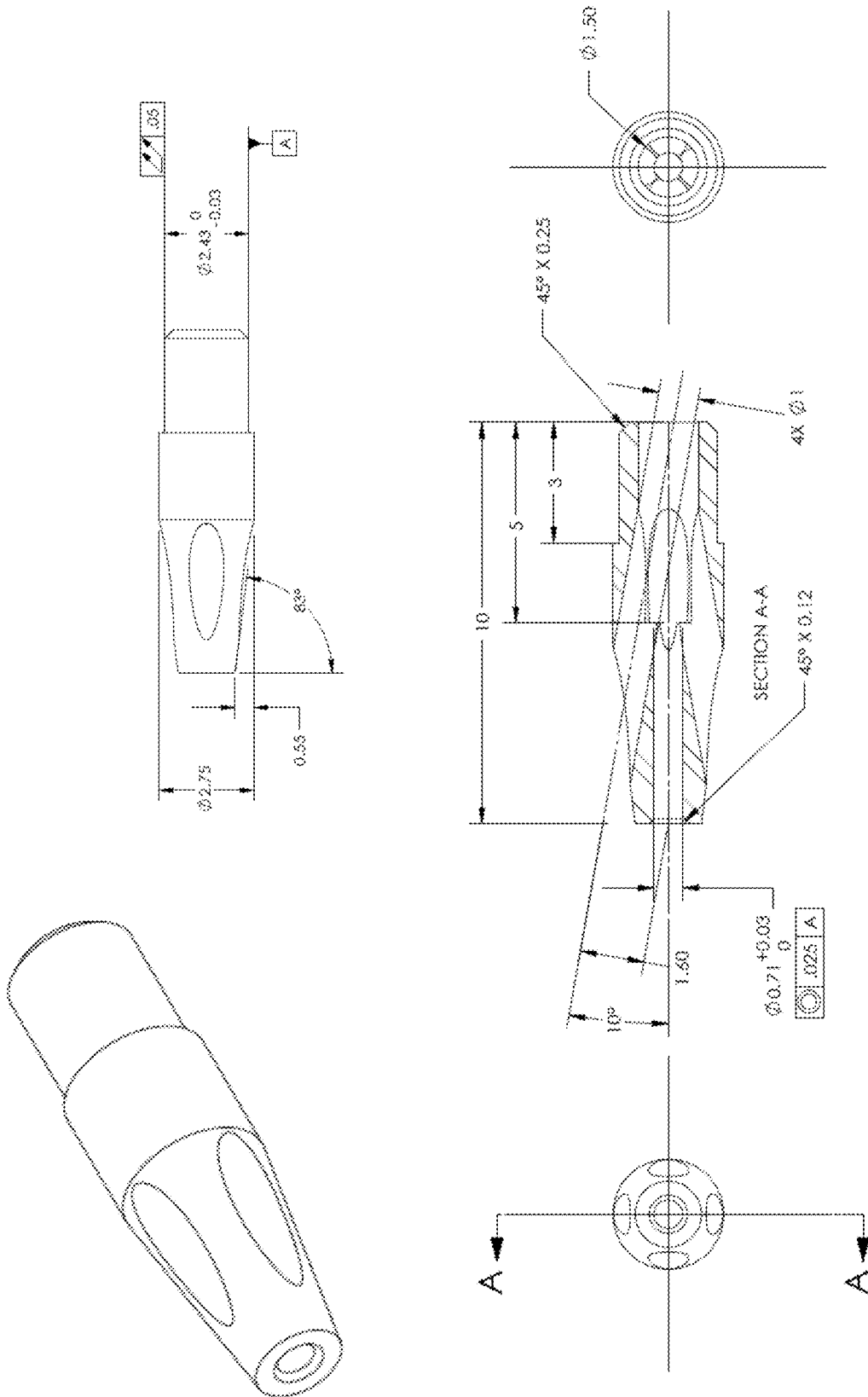

Figure 29A

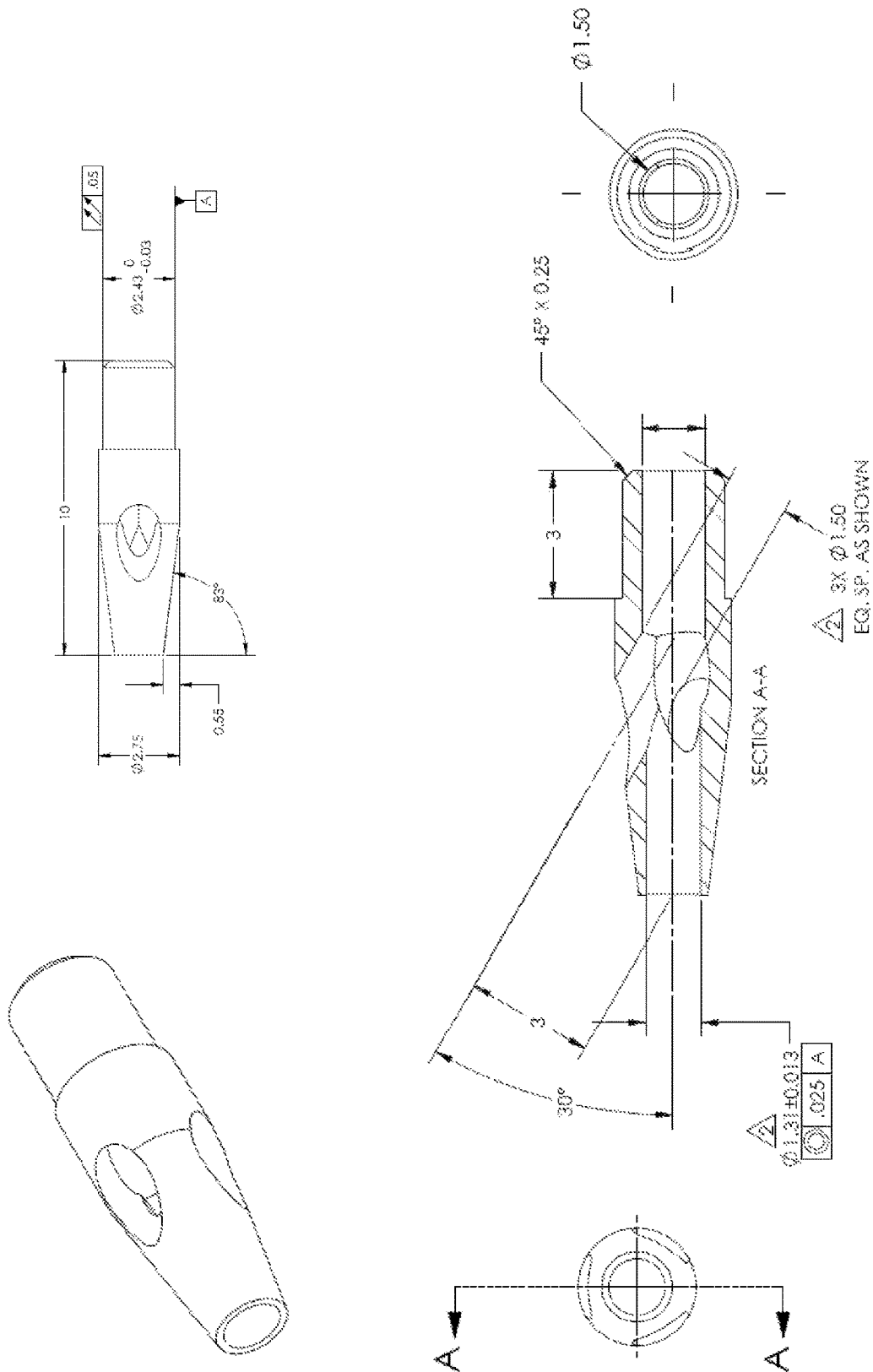

Figure 29B



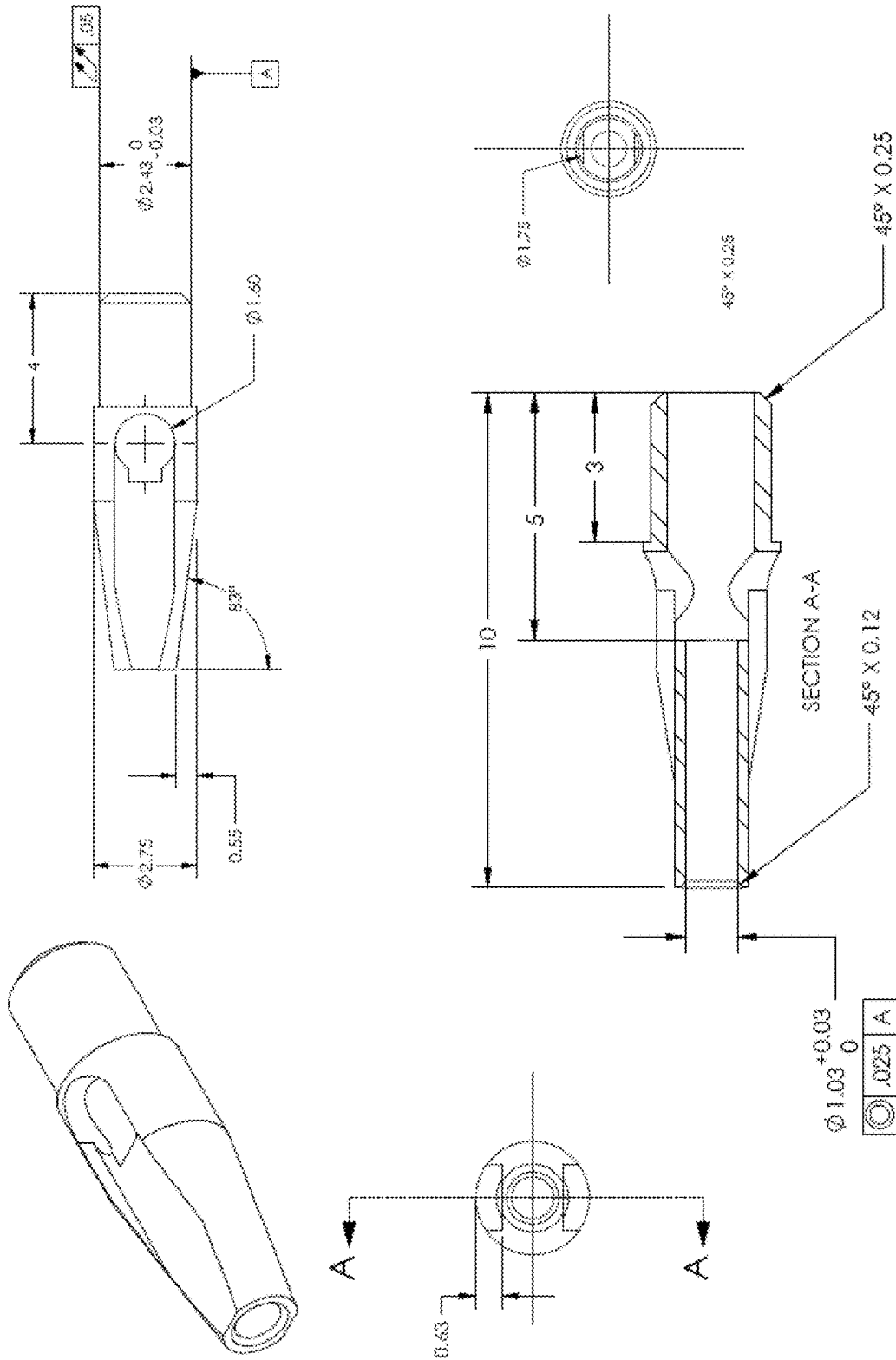

Figure 29C

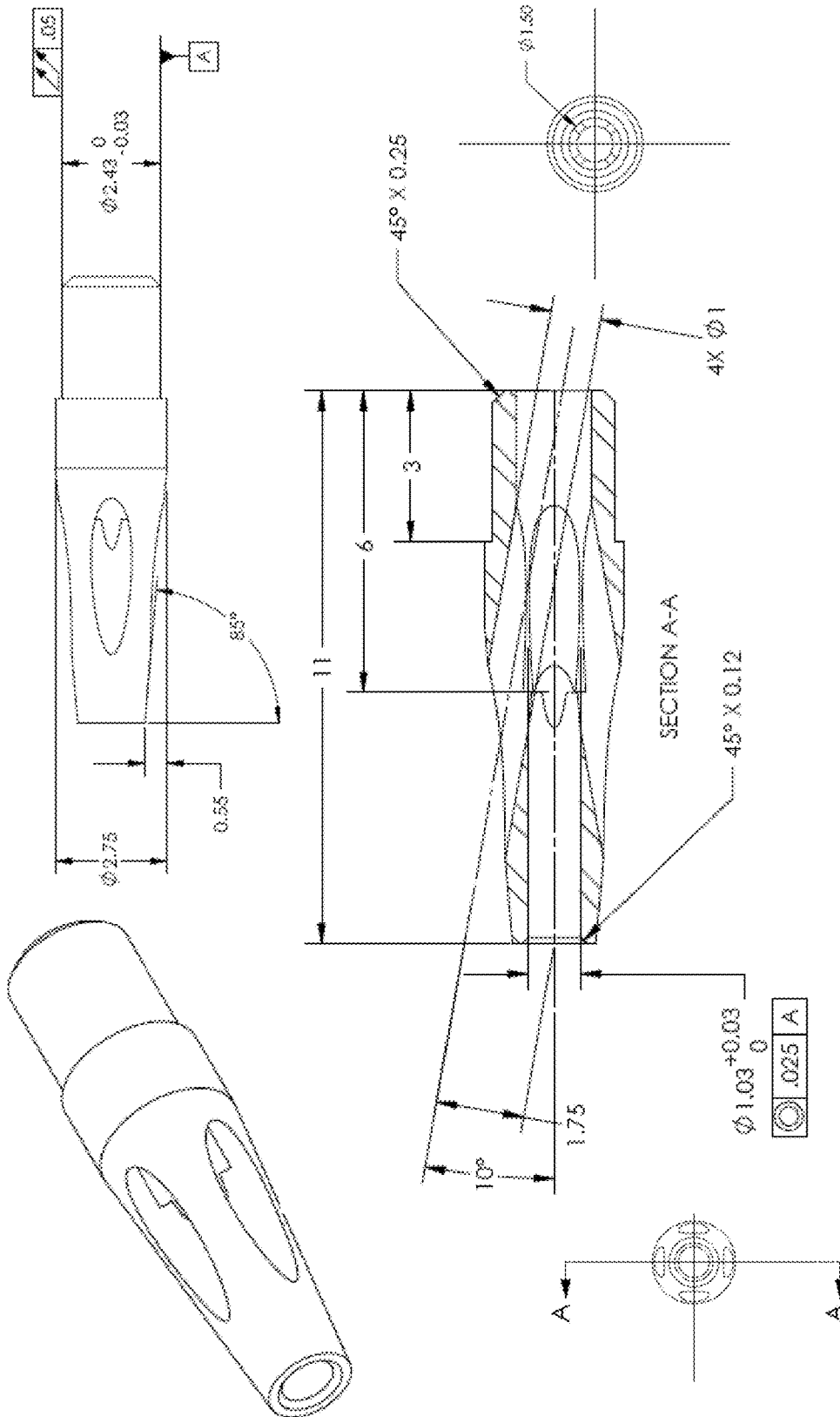

Figure 29D

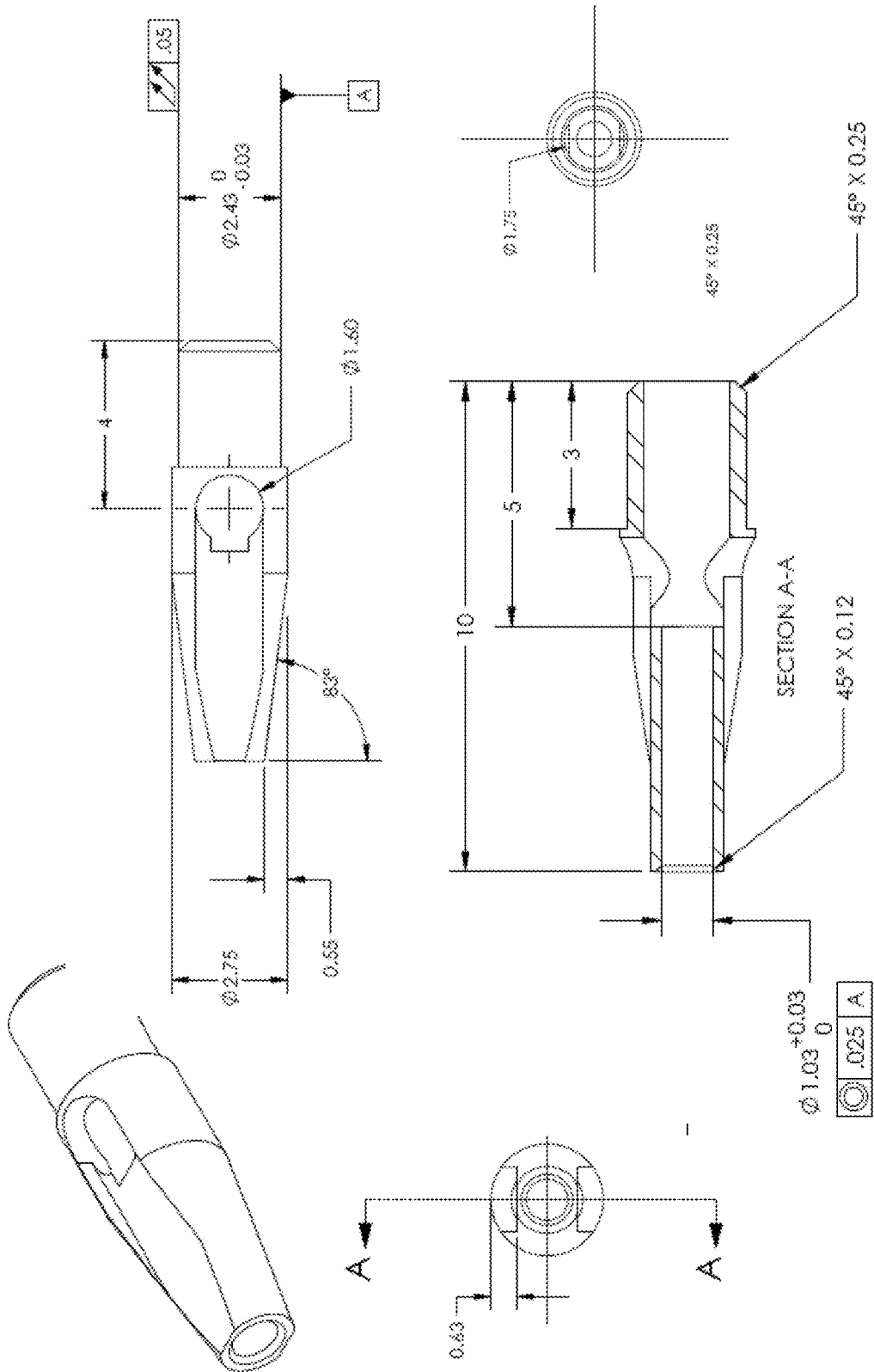

Figure 29E

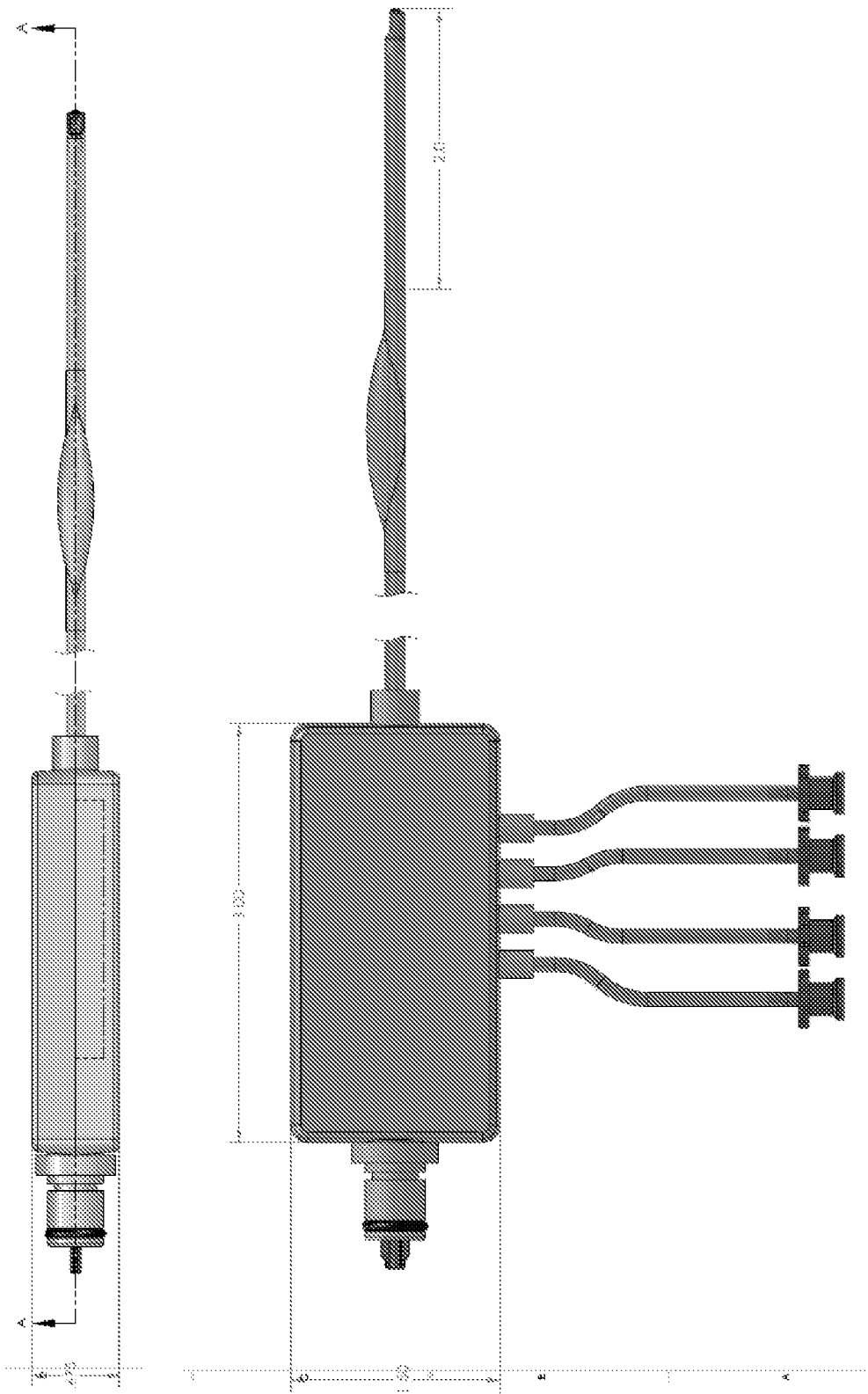

Figure 30A

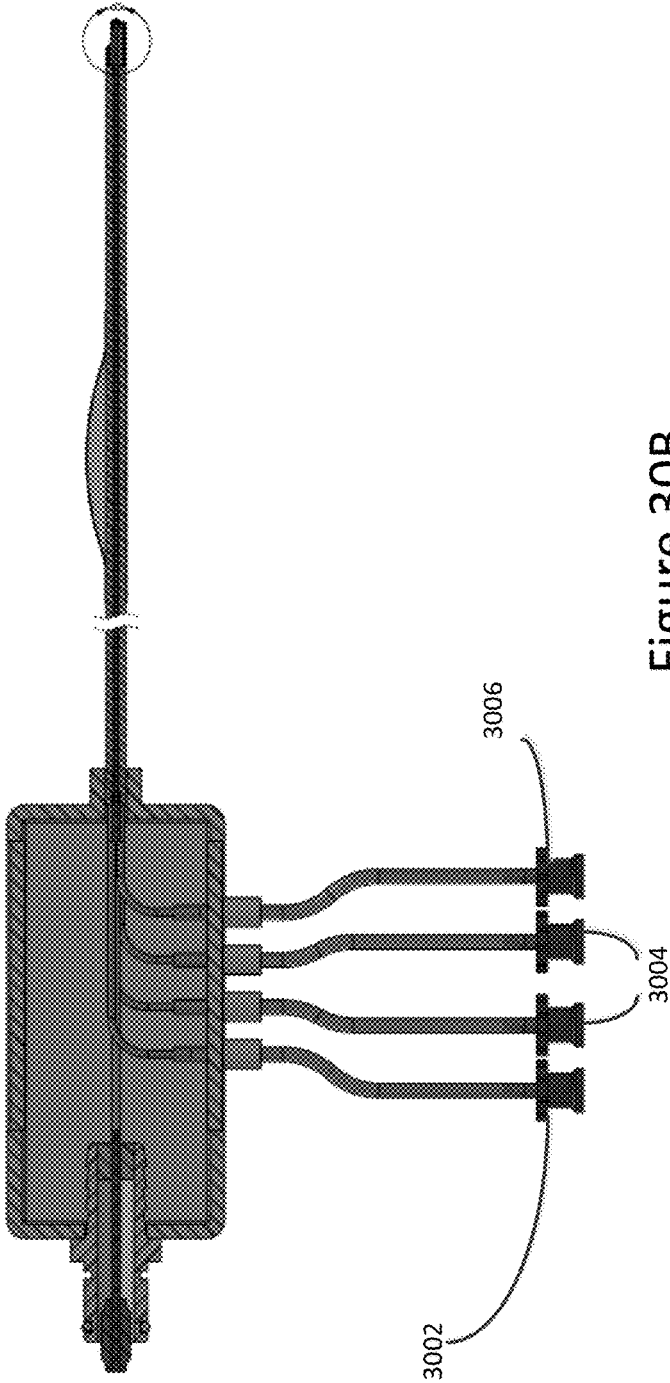

Figure 30B

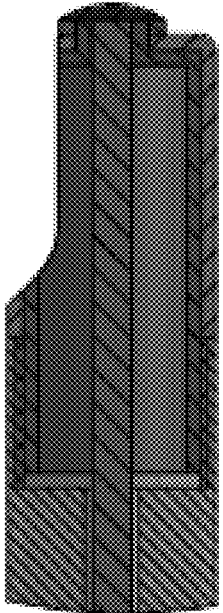

Figure 30C

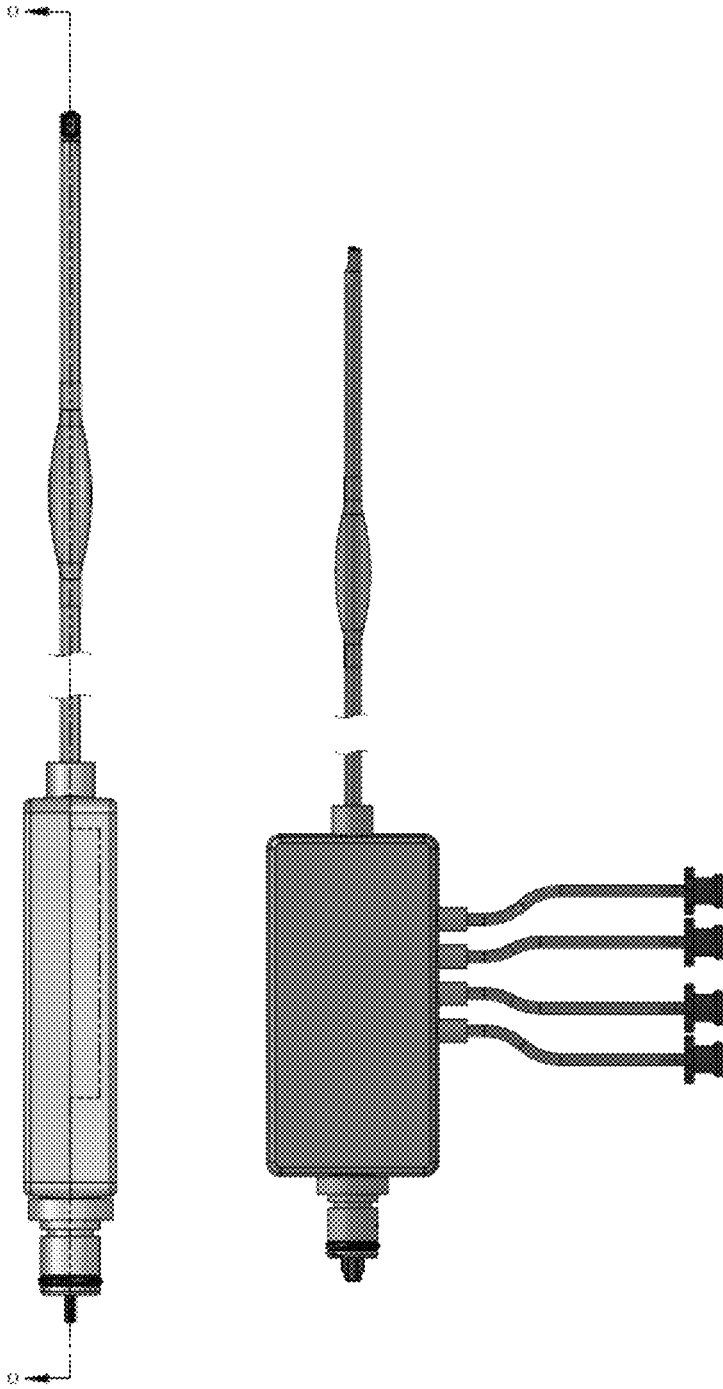

Figure 31A

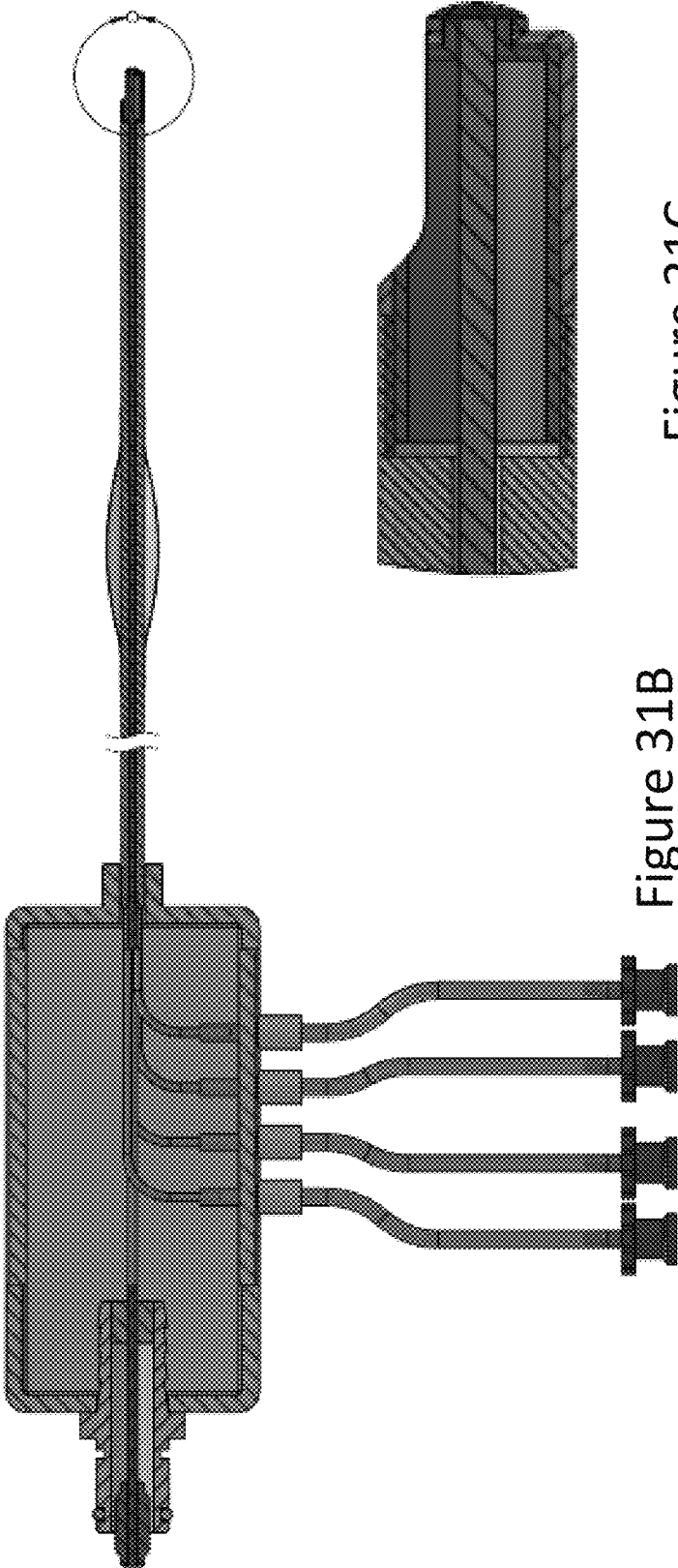

Figure 31B

Figure 31C

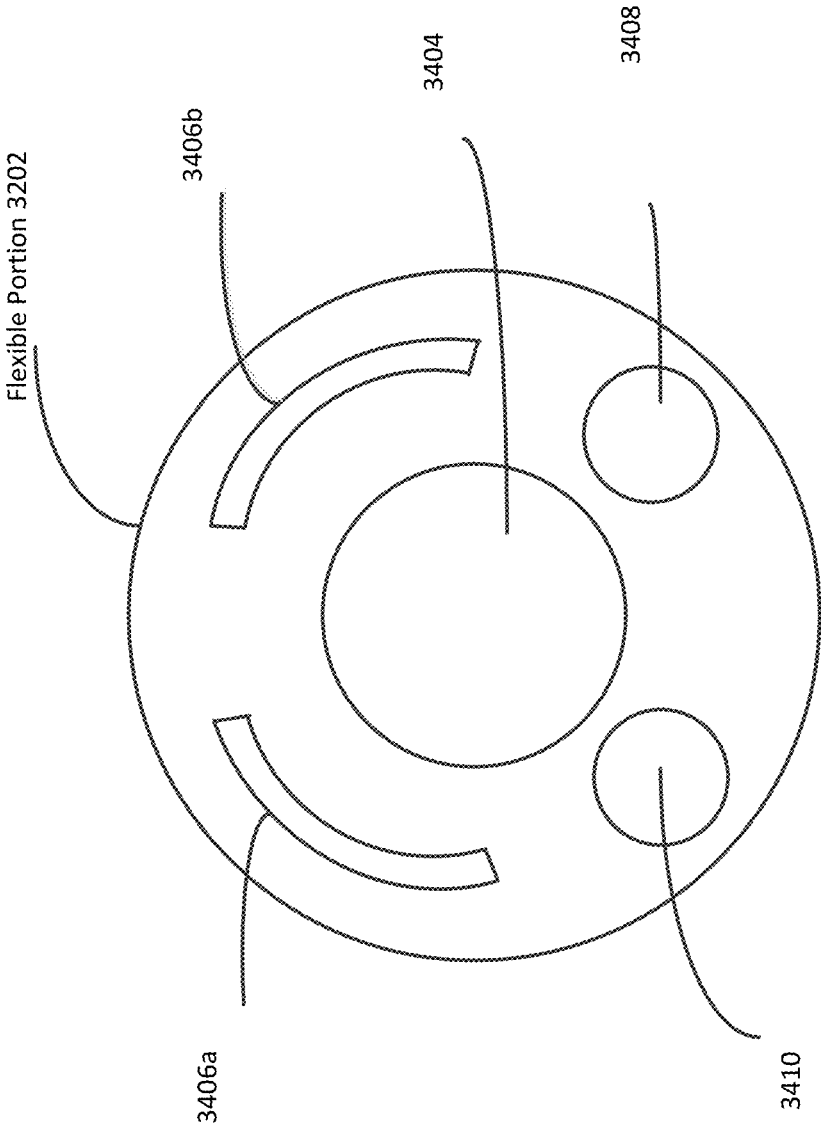

Figure 32



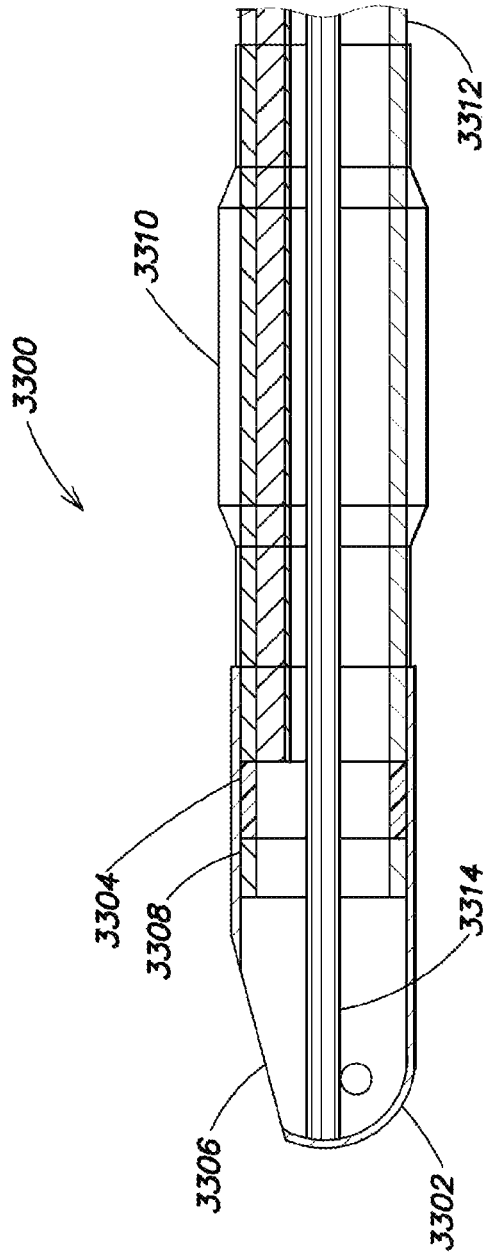

FIG. 33

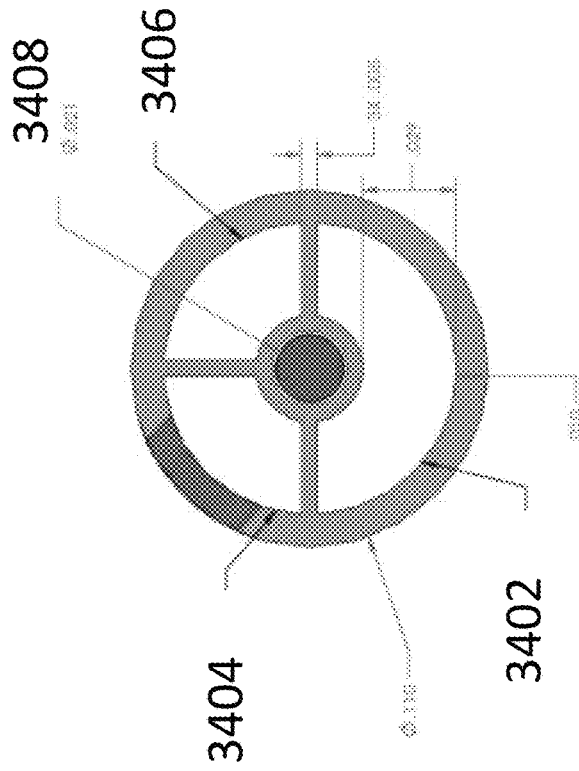

Figure 34A

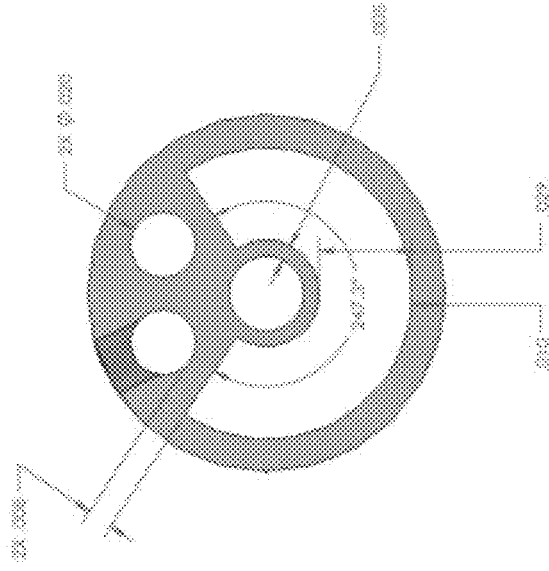

Figure 34B

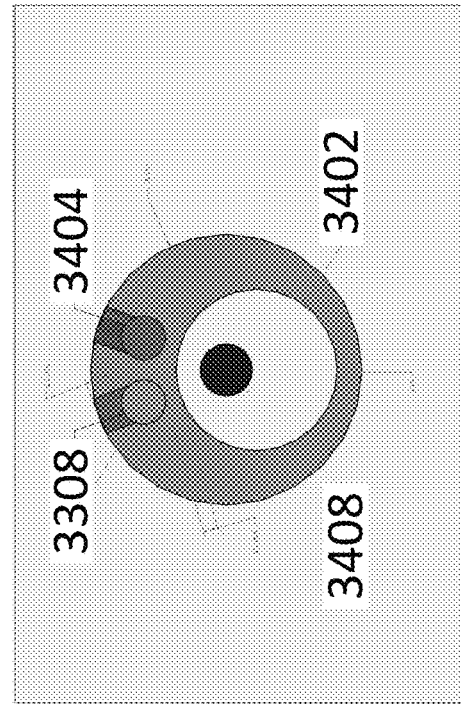

Figure 34C

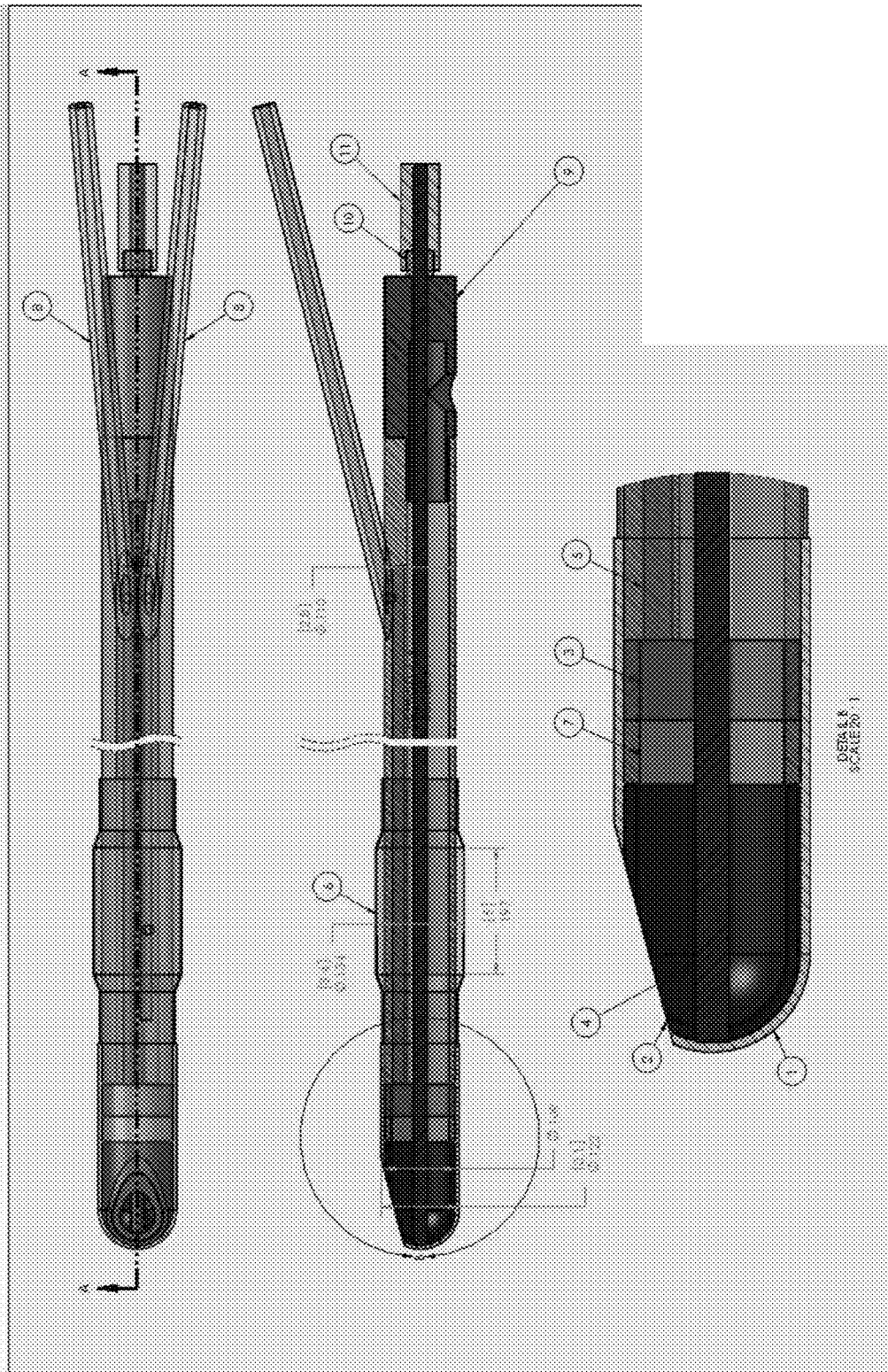

Figure 35

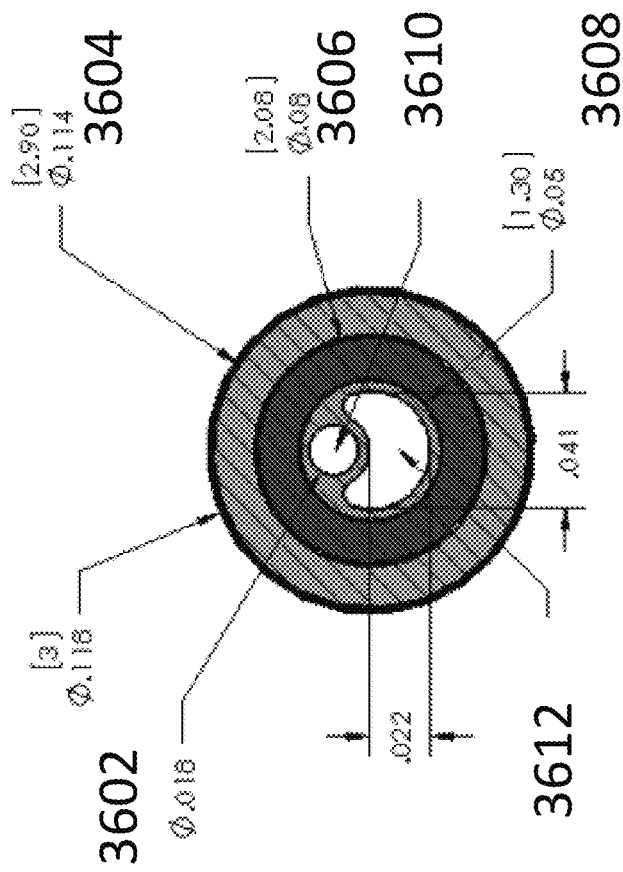

Figure 36

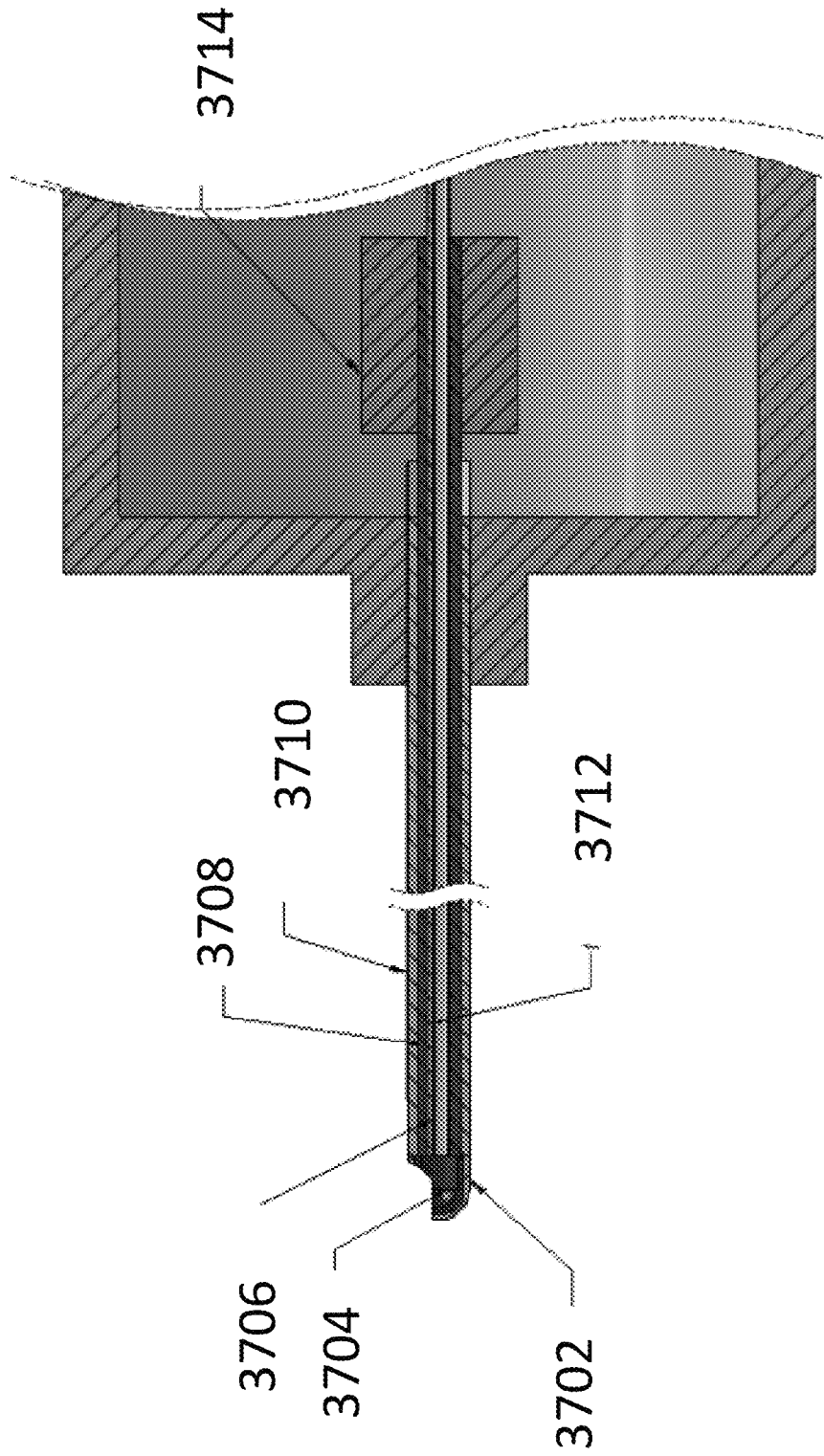

Figure 37

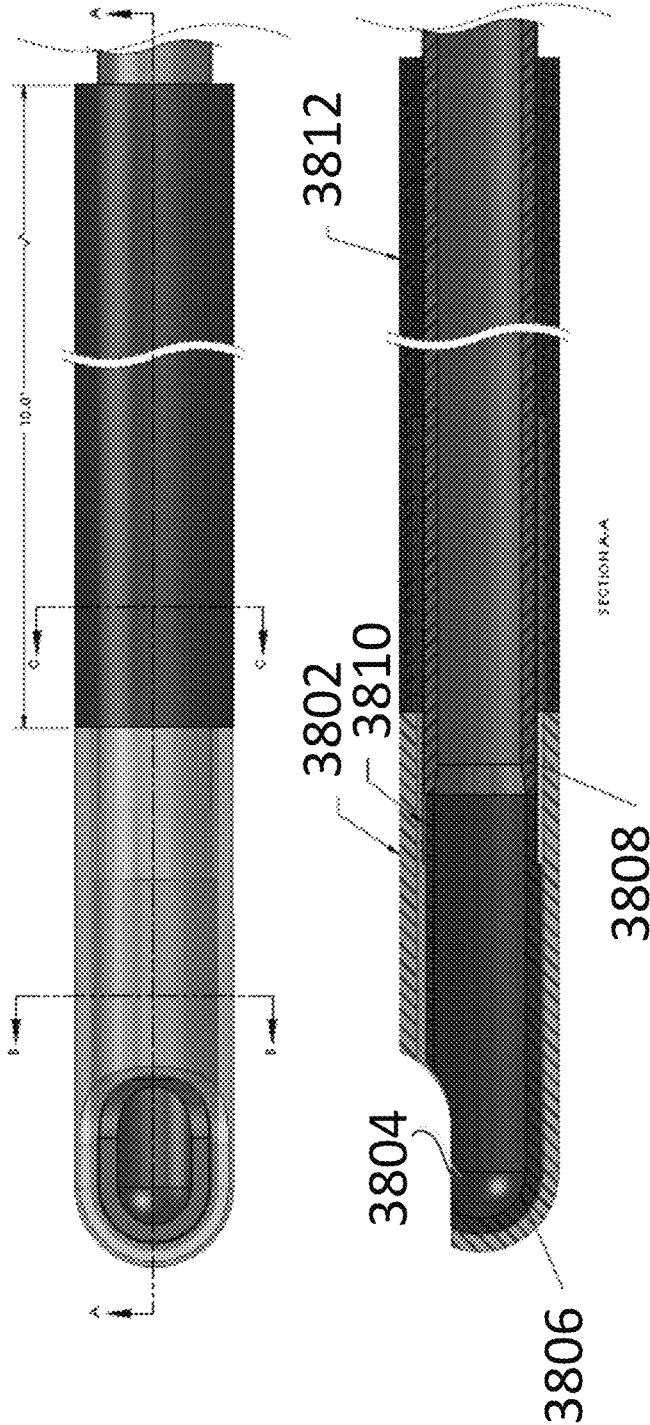

Figure 38

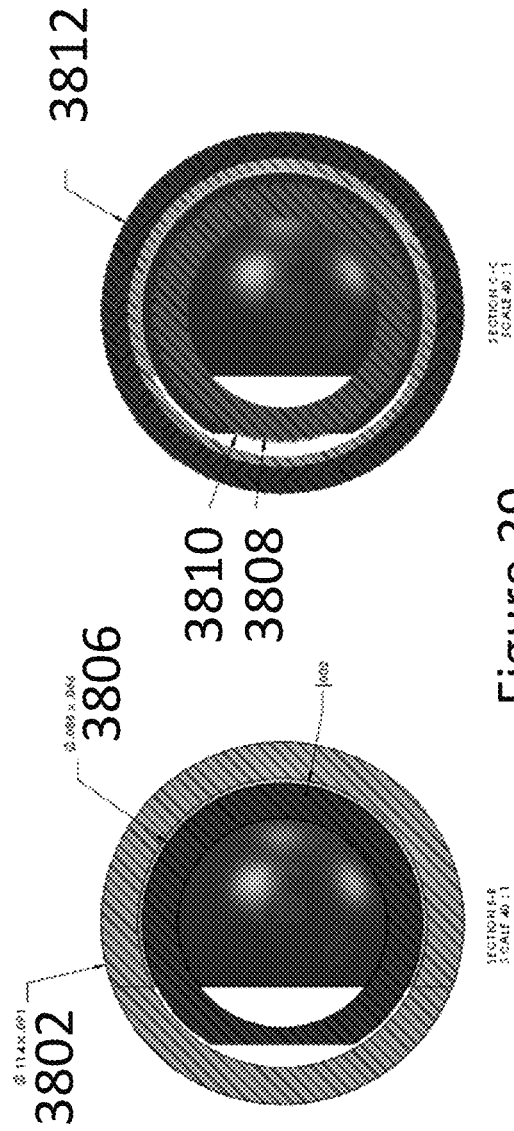

Figure 39

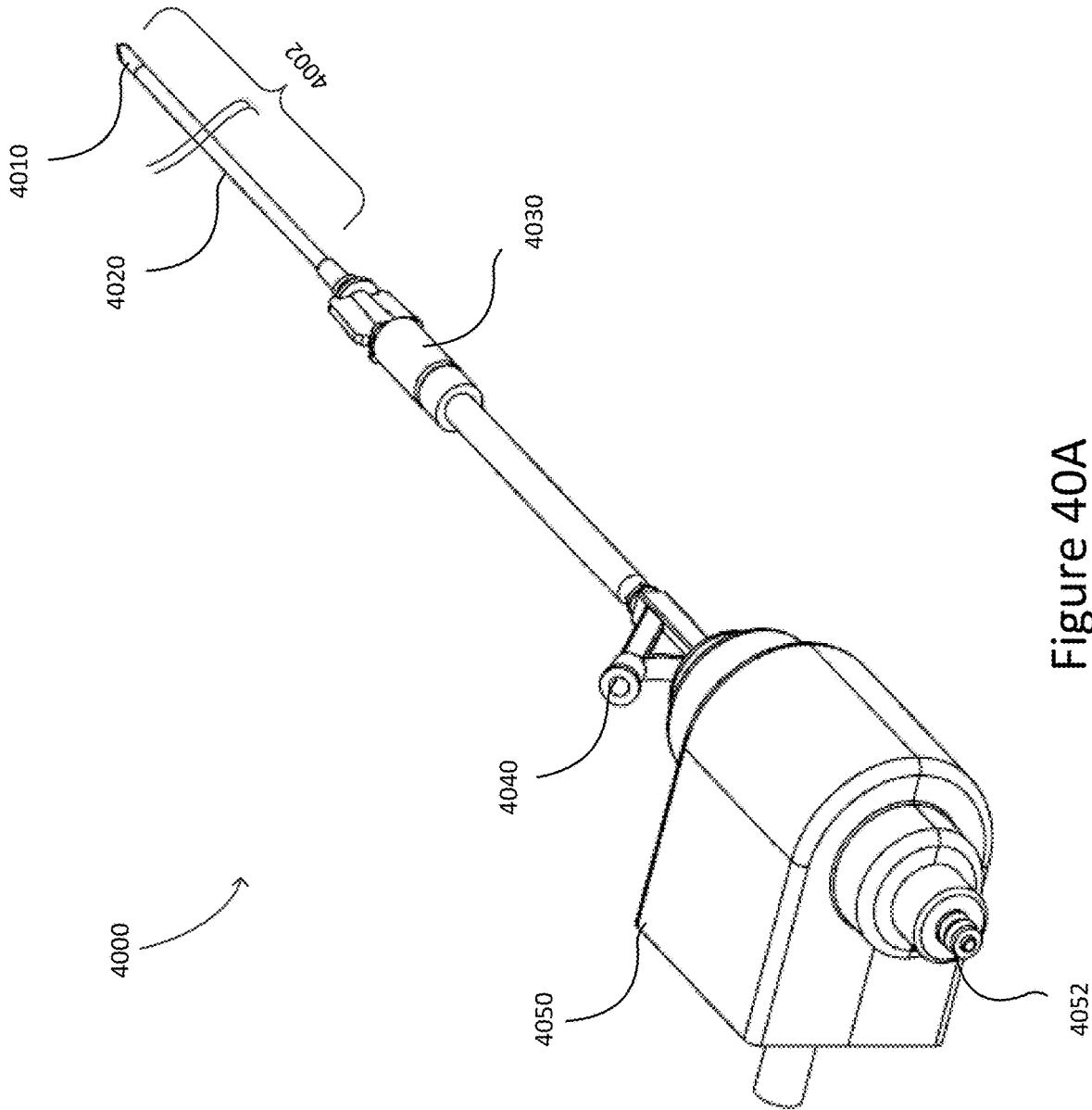

Figure 40A



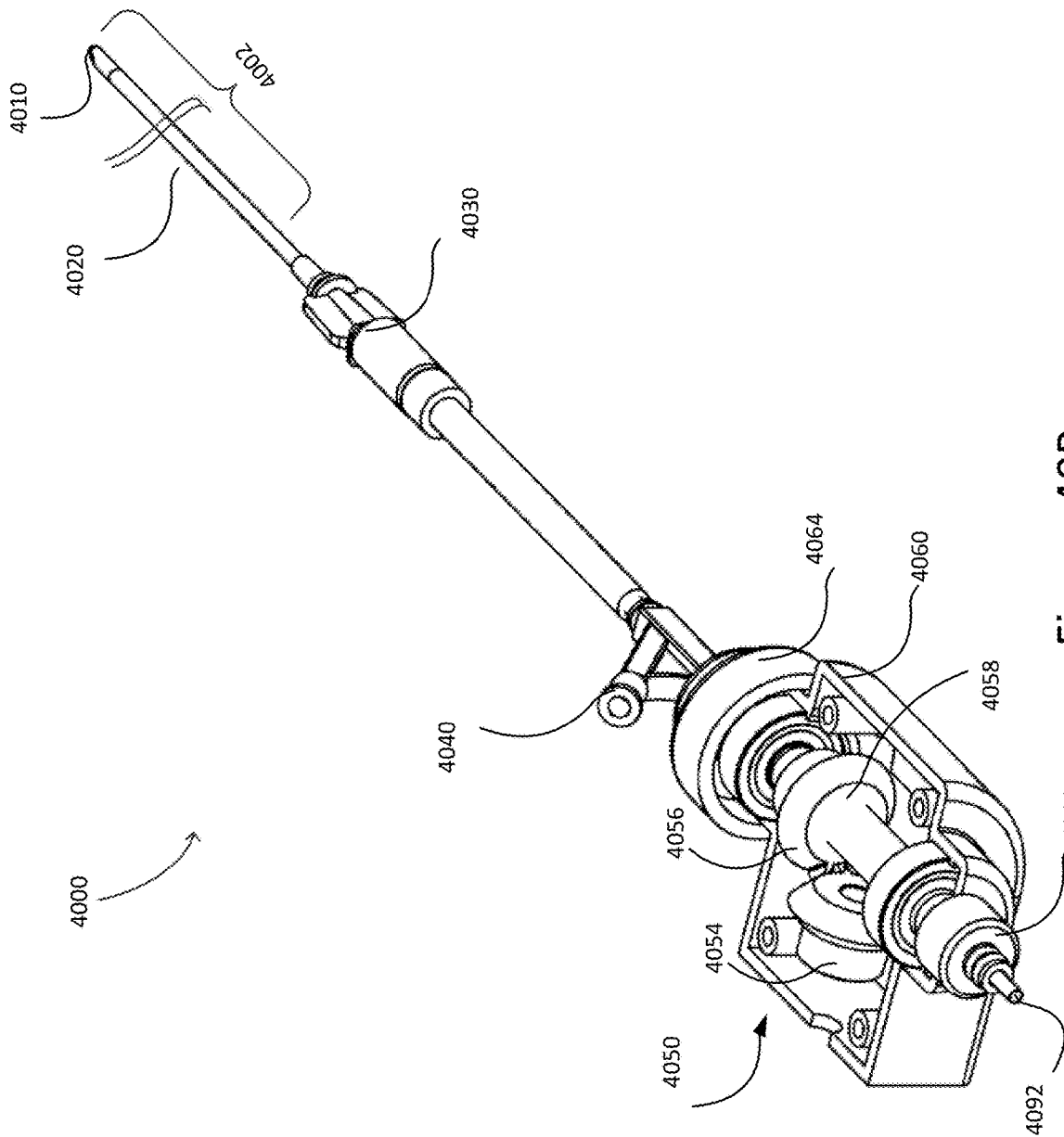

Figure 40B

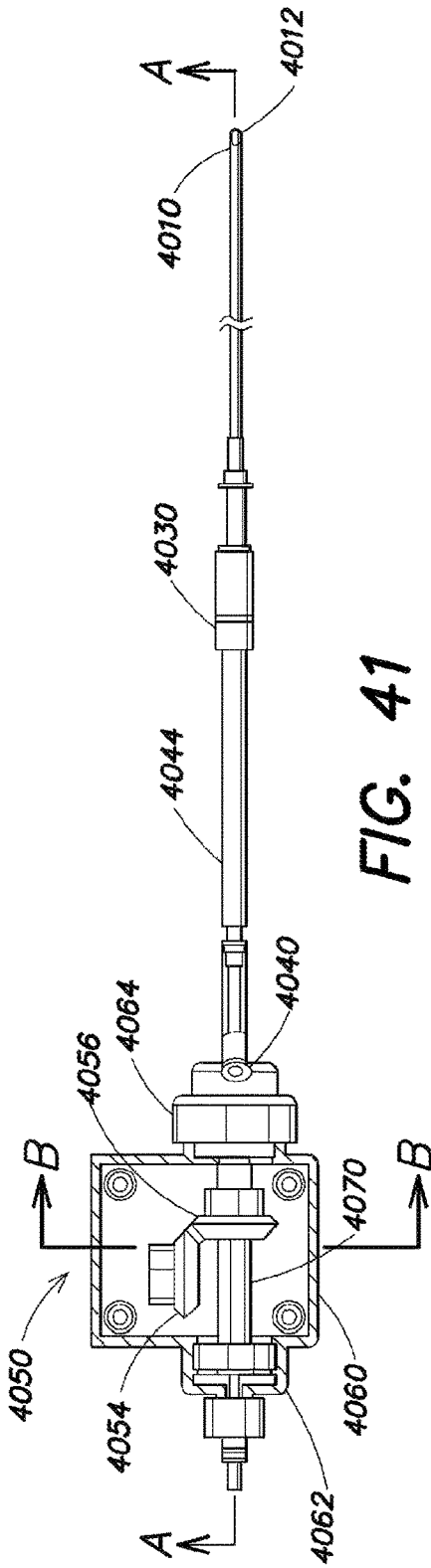

FIG. 41

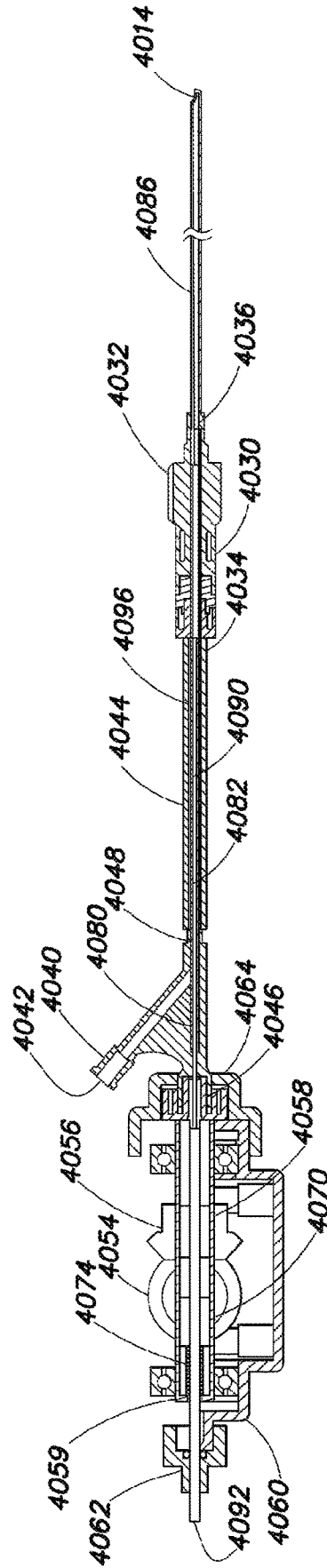

FIG. 42

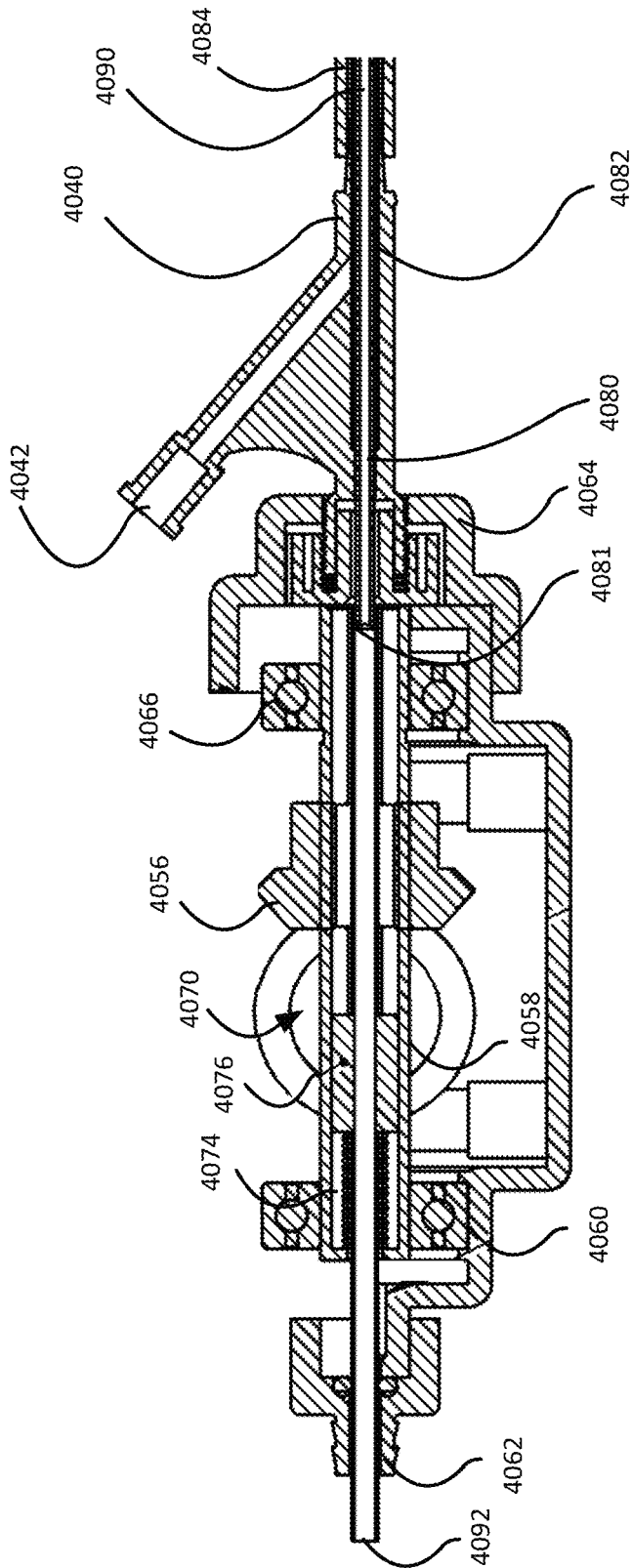

Figure 43

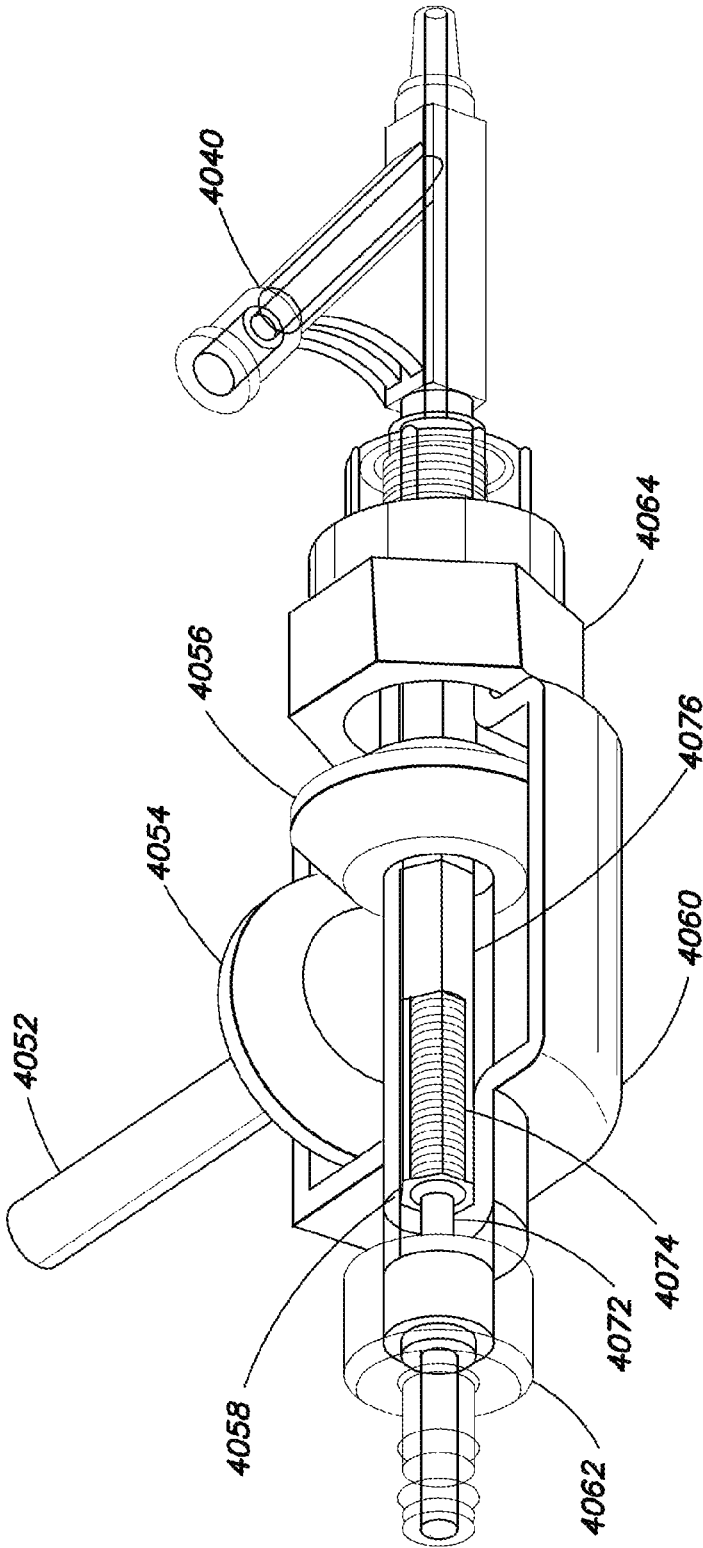

FIG. 44

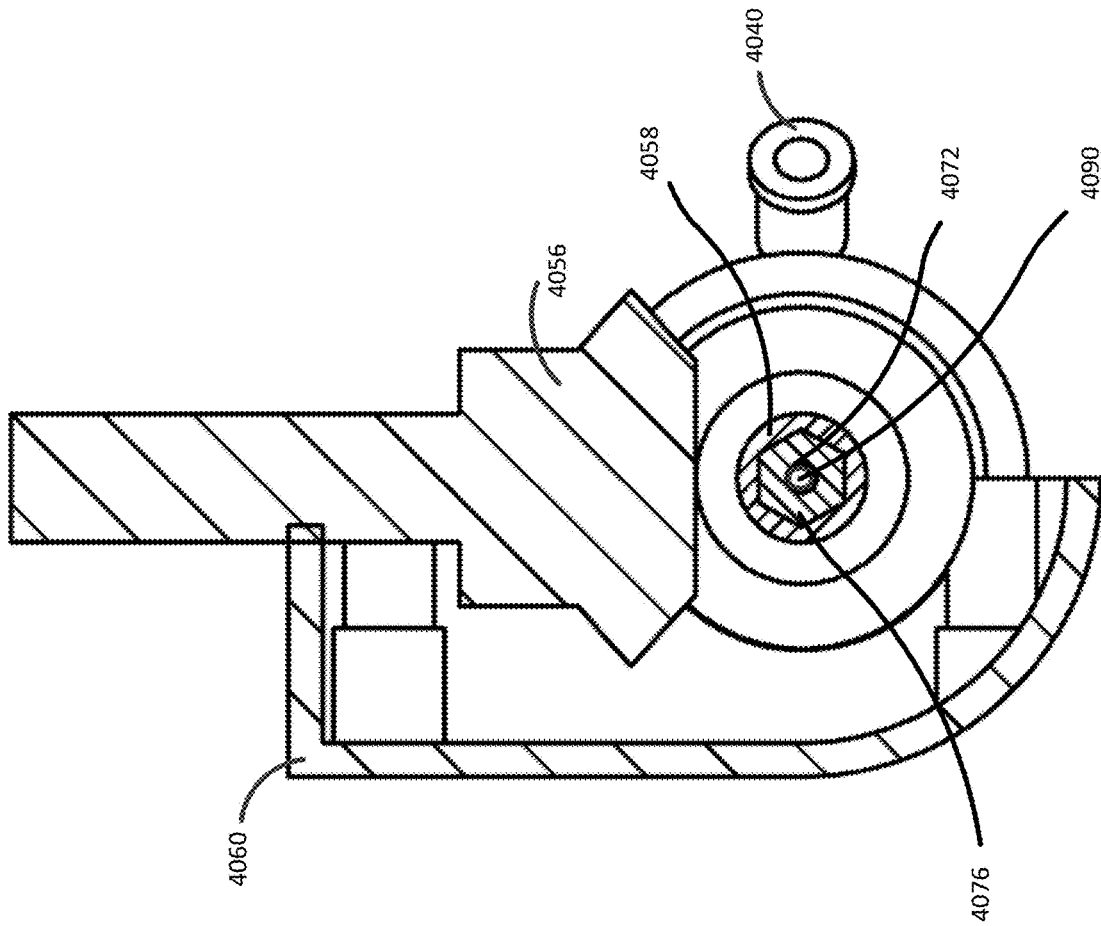

Figure 45

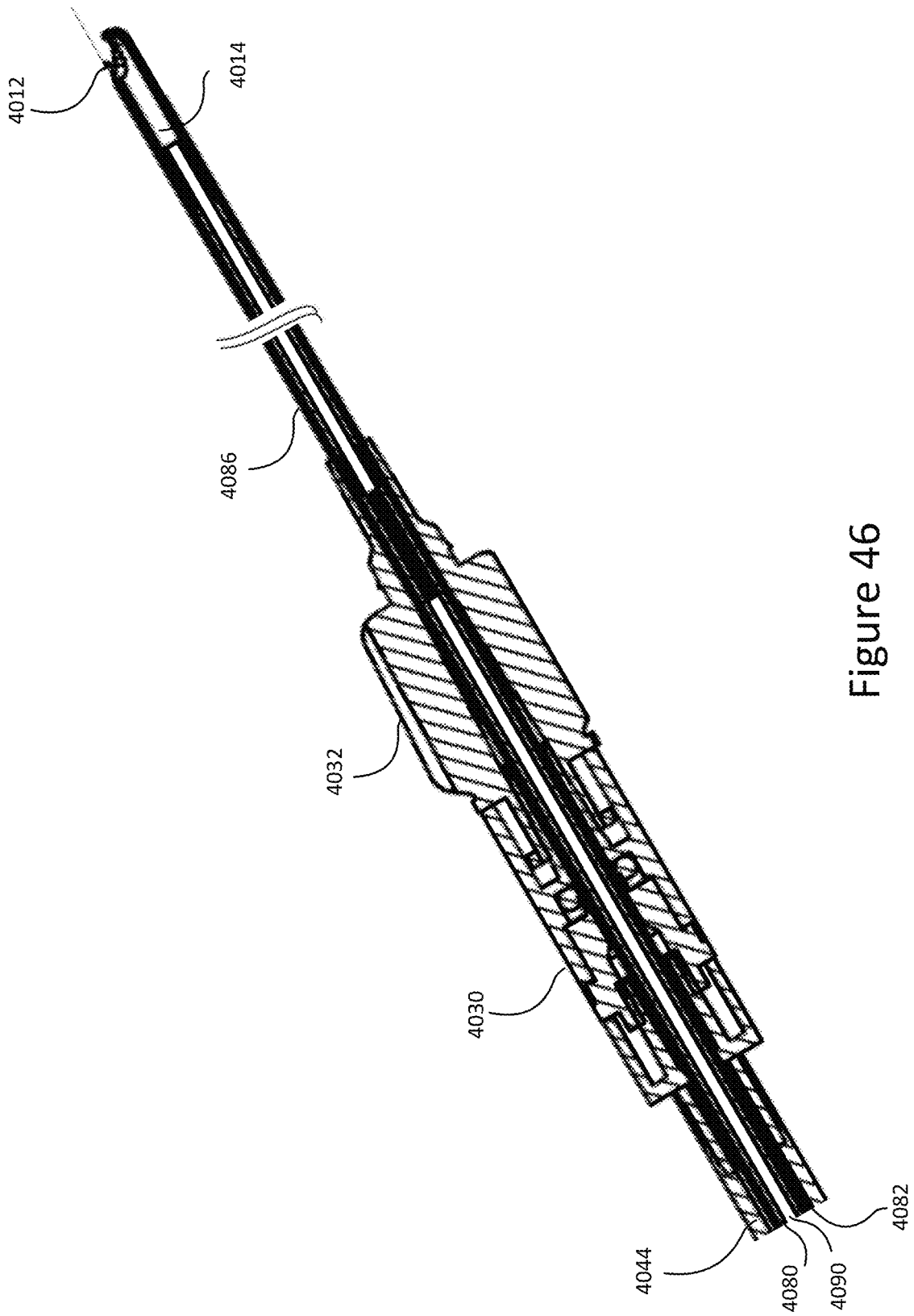

Figure 46

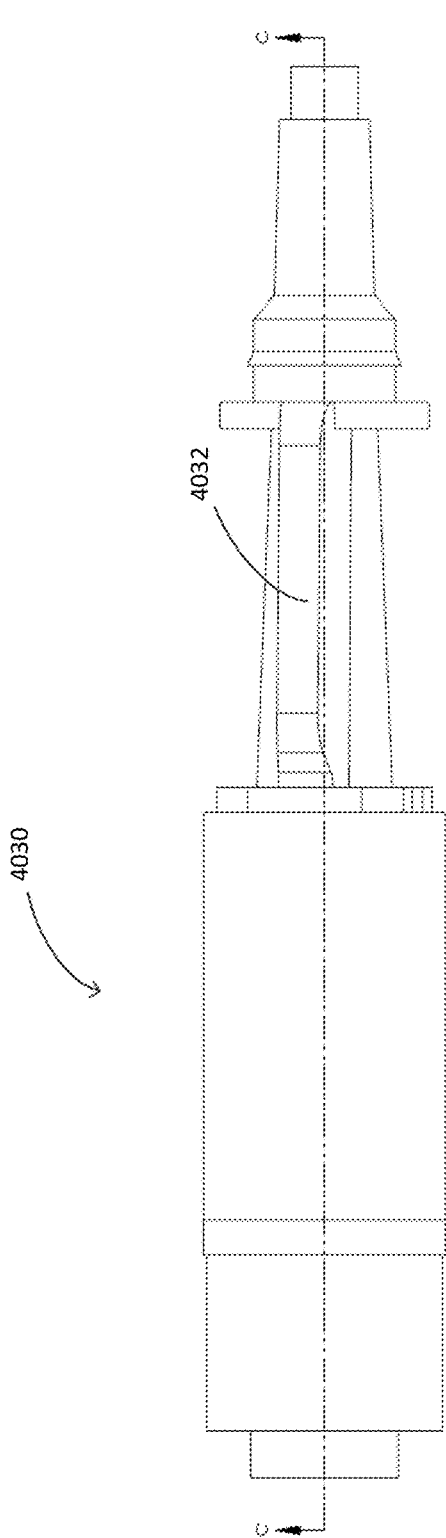

Figure 47A

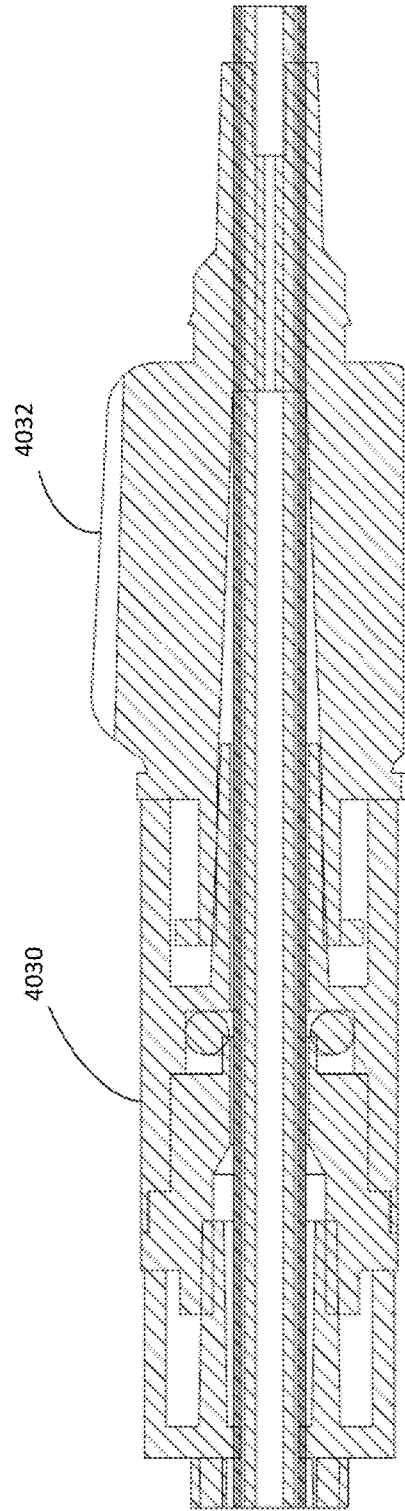

Figure 47B

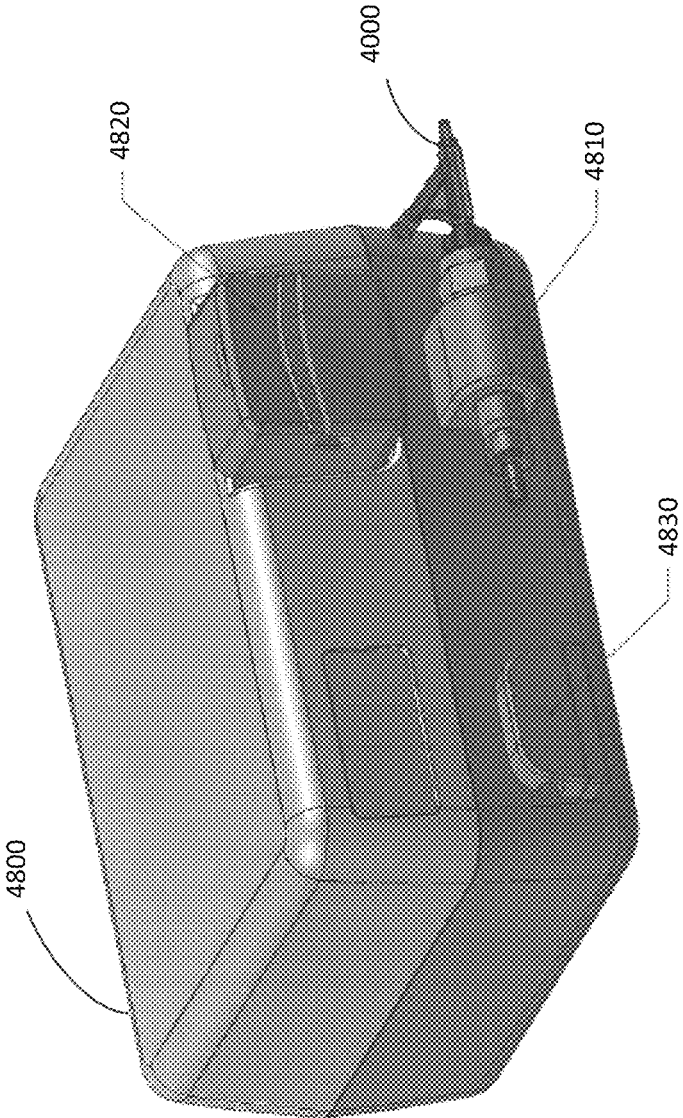

Figure 48



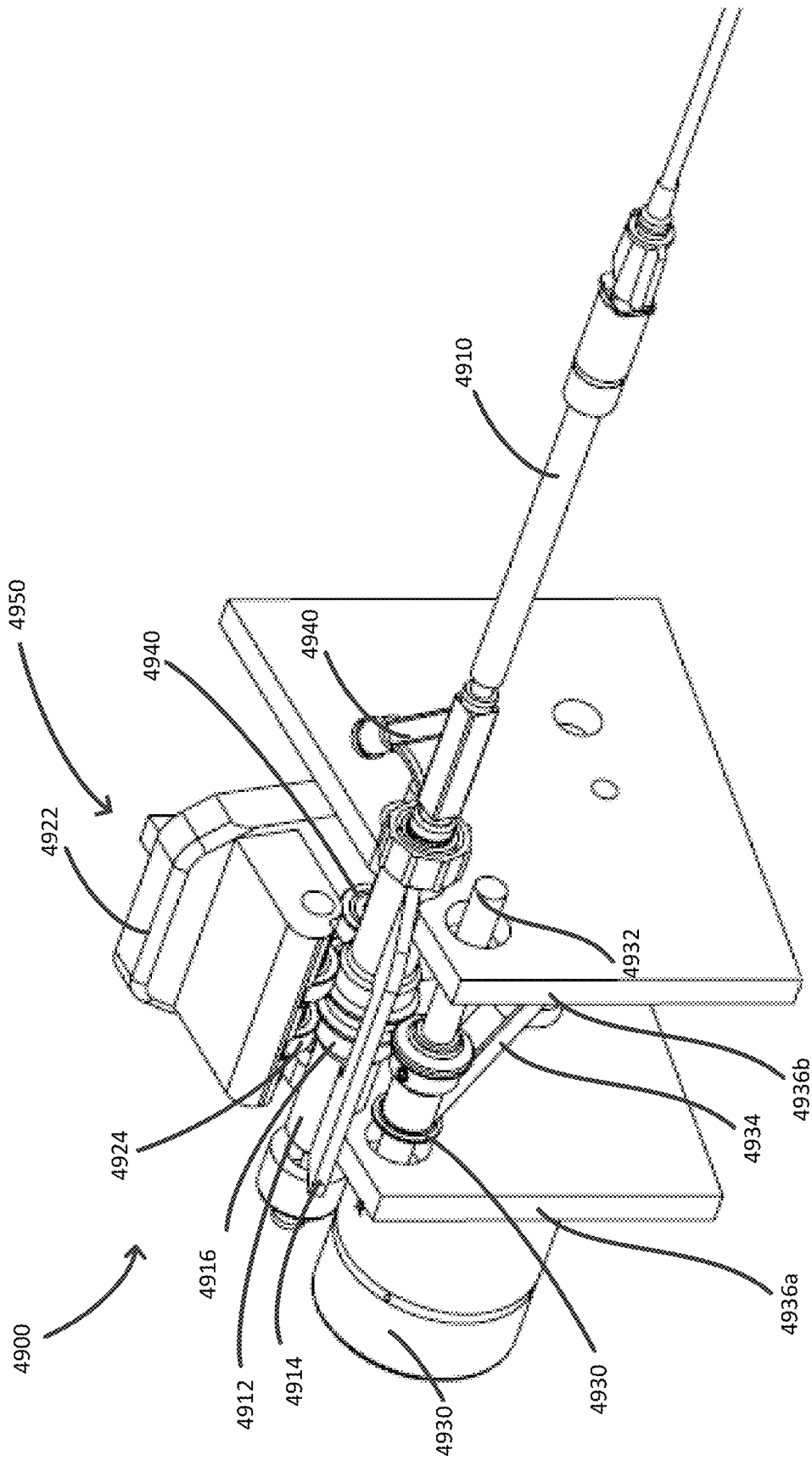

Figure 49

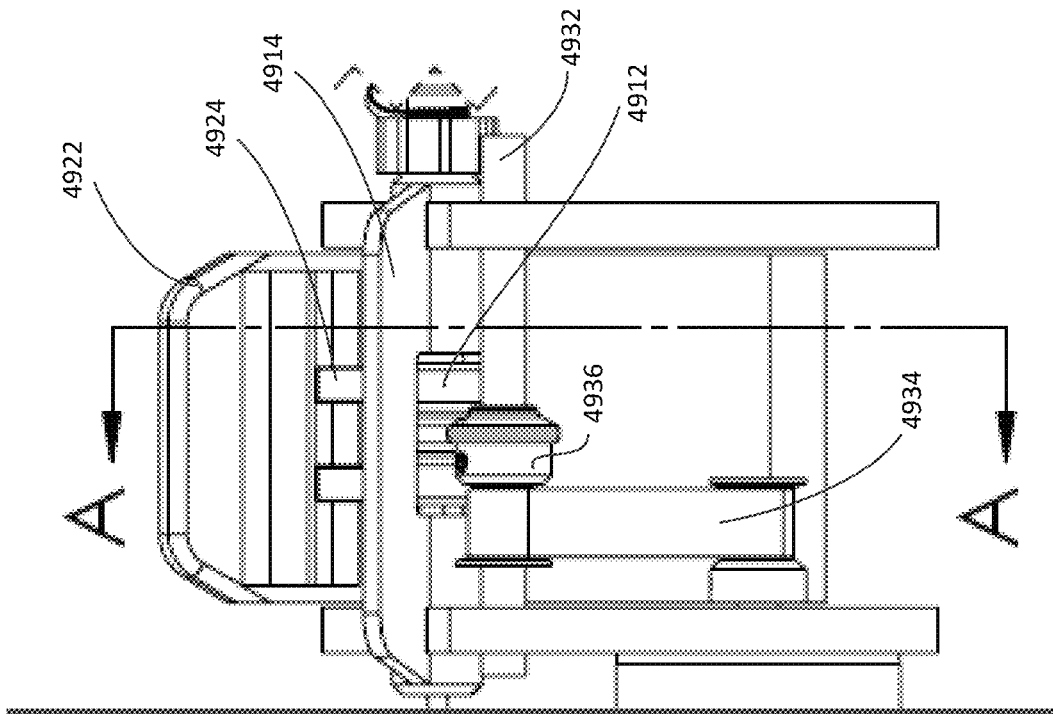

Figure 50A

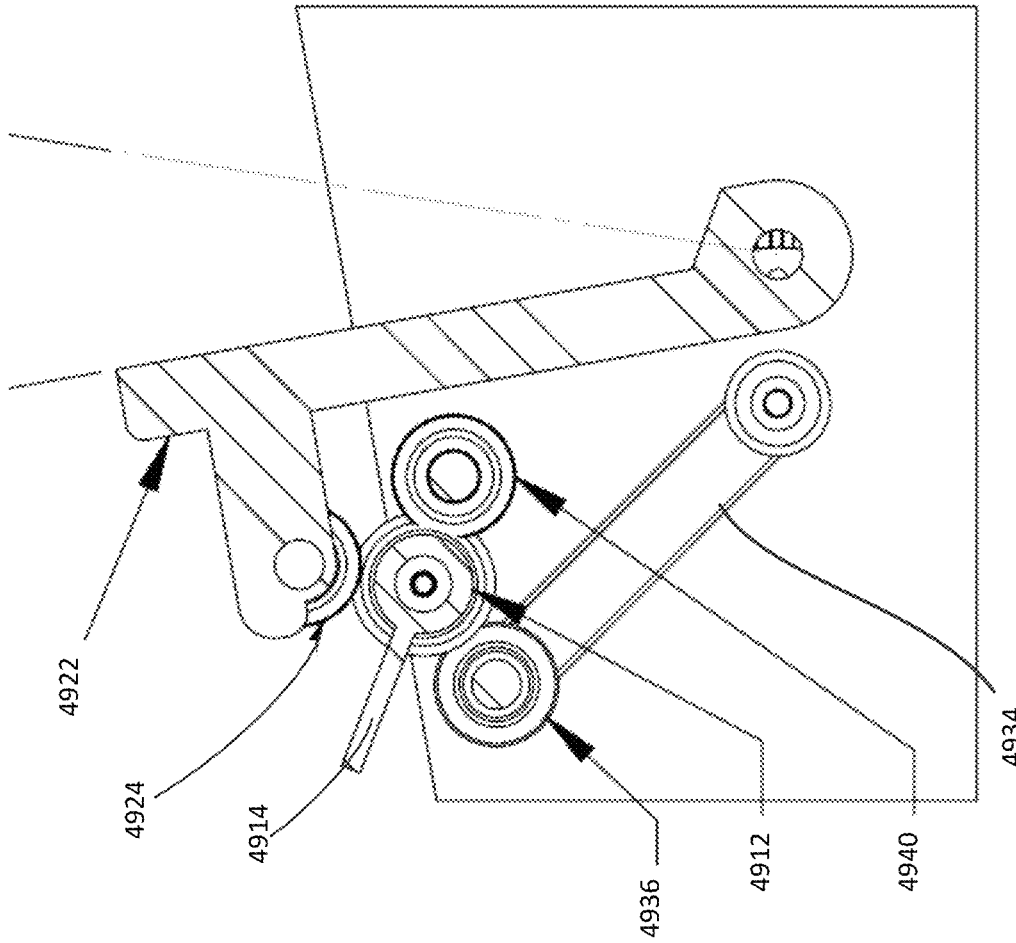

Figure 50B

## INSERTABLE ENDOSCOPIC INSTRUMENT FOR TISSUE REMOVAL

### RELATED APPLICATIONS

This application claims the benefit of and priority to U.S. application Ser. No. 14/316,203, entitled "Insertable Endoscopic Instrument for Tissue Removal," filed on Jun. 26, 2014, which claims the benefit of and priority to U.S. application Ser. No. 14/280,202, entitled "Insertable Endoscopic Instrument for Tissue Removal," filed on May 16, 2014, which claims the benefit of and priority to U.S. Provisional Patent Application 61/824,760, entitled "Insertable Endoscopic Instrument for Tissue Removal," filed on May 17, 2013 and to U.S. patent application Ser. No. 13/336,491, entitled "Endoscopic Tool For Debriding and Removing Polyps," filed on Dec. 23, 2011, which claims the benefit of and priority to U.S. Provisional Patent Application 61/566,472, entitled "Endoscopic Tool For Debriding and Removing Polyps," filed on Dec. 2, 2011, each of which is incorporated herein by reference in its entirety for all purposes.

### BACKGROUND OF THE INVENTION

Colon cancer is the third leading cause of cancer in the United States but is the second leading cause of cancer-related deaths. Colon cancer arises from pre-existing colon polyps (adenomas) that occur in as many as 35% of the US population. Colon polyps can either be benign, precancerous or cancerous. Colonoscopy is widely regarded as an excellent screening tool for colon cancer that is increasing in incidence worldwide. According to the literature, a 1% increase in colonoscopy screening results in a 3% decrease in the incidence of colon cancer. The current demand for colonoscopy exceeds the ability of the medical system to provide adequate screening. Despite the increase in colon cancer screening the past few decades, only 55% of the eligible population is screened, falling far short of the recommended 80%, leaving millions of patients at risk.

Due to the lack of adequate resources, operators performing a colonoscopy typically only sample the largest polyps, exposing the patient to sample bias by typically leaving behind smaller less detectable polyps that could advance to colon cancer prior to future colonoscopy. Because of the sample bias, a negative result from the sampled polyps does not ensure the patient is truly cancer-free. Existing polyps removal techniques lack precision are cumbersome and time consuming.

At present, colon polyps are removed using a snare that is introduced into the patient's body via a working channel defined within an endoscope. The tip of the snare is passed around the stalk of the polyp to cut the polyp from the colon wall. Once the cut has been made, the cut polyp lies on the intestinal wall of the patient until it is retrieved by the operator as a sample. To retrieve the sample, the snare is first removed from the endoscope and a biopsy forceps or suction is fed through the same channel of the endoscope to retrieve the sample.

Accordingly, there is a need for an improved endoscopic instrument that increases the precision and speed of polyp removal for biopsy.

### SUMMARY OF THE INVENTION

An improved endoscopic instrument is provided that can precisely remove sessile polyps and efficiently obtain

samples of multiple polyps from a patient. In particular, the improved endoscopic instrument is capable of debriding one or more polyps and retrieving the debrided polyps without having to alternate between using a separate cutting tool and a separate sample retrieving tool. The sampling can be integrated with colonoscopy inspection. In some implementations, the endoscopic instrument can cut and remove tissue from within a patient. In some such implementations, the endoscopic instrument can cut and remove tissue substantially simultaneously from within a patient accessed through a flexible endoscope.

In one aspect, an endoscopic instrument insertable within a single instrument channel of an endoscope includes a power-driven instrument head configured to resect material at a site within a subject having been reached by a flexible endoscope with working channel. The power-driven instrument head has a first distal end and a first proximal end. The first distal end of the power-driven instrument head defines a material entry port through which the resected material can enter the flexible endoscopic instrument. A body is coupled to the first proximal end of the power-driven instrument head and configured to drive the power-driven instrument head. The body includes a flexible portion that has a second distal end and a second proximal end. The second proximal end of the flexible portion defines a material exit port. An aspiration channel extends from the material entry port of the power-driven instrument head to the material exit port of the flexible portion. The second proximal end of the flexible portion is configured to couple to a vacuum source such that the resected material entering the aspiration channel via the material entry port is removed from the aspiration channel at the material exit port while the endoscopic instrument is disposed within an instrument channel of a flexible endoscope.

In some implementations, the body further includes a powered actuator. The powered actuator is coupled to the first proximal end of the power-driven instrument head and configured to drive the power-driven instrument head. In some implementations, the powered actuator is one of a hydraulically powered actuator, a pneumatically powered actuator or an electrically powered actuator. In some implementations, the powered actuator includes at least one of an electric motor, a tesla rotor, and a vane rotor. In some implementations, the endoscopic instrument includes an energy storage component configured to power the powered actuator. In some implementations, the aspiration channel is defined by the power-driven instrument head, the powered actuator and the flexible portion.

In some implementations, the powered actuator is one of a hydraulically powered actuator or a pneumatically powered actuator. In some such implementations, the flexible portion includes a fluid inlet tubular member configured to supply irrigation to actuate the power actuator and a fluid outlet tubular member configured to remove the fluid being supplied to actuate the actuator. In some implementations, the flexible portion includes an aspiration tubular member that defines a proximal portion of the aspiration channel.

In some implementations, the powered actuator includes a hollow portion, the hollow portion fluidly coupling the material entry port of the power-driven instrument head and the material exit port of the flexible portion.

In some implementations, the instrument includes an engagement assembly configured to contact the walls of the instrument channel of the endoscope when actuated. In some implementations, the engagement assembly includes a compliant ring structure configured to be deformed.

In some implementations, the power-driven instrument head includes an outer structure and a cutting shaft disposed within the outer structure, the cutting shaft coupled to the powered actuator and configured to rotate relative to the outer structure when the powered actuator is actuated. In some implementations, the cutting shaft includes a hollow portion and the material entry port.

In some implementations, the flexible portion includes a hollow flexible torque cable. The flexible torque cable has a distal region configured to couple to the first proximal end of the power-driven instrument head and has a proximal region configured to couple to a powered actuator. In some implementations, the flexible torque cable defines a portion of the aspiration channel. The distal region of the flexible torque cable is fluidly coupled to the material entry port of the power-driven instrument head and the proximal region of the flexible torque cable includes the material exit port.

In some implementations, the instrument has an outer diameter that is less than about 5 mm. In some implementations, the flexible portion is at least 40 times as long as the power-driven instrument head. In some implementations, the outer diameter of the powered actuator is less than about 4 mm.

According to another aspect, an endoscopic instrument includes a power-driven instrument head configured to resect material at a site within a subject. The power-driven instrument head includes a cutting tip and a material entry port configured to allow material to enter a distal end of the endoscopic instrument. A body is coupled to the power-driven instrument head. The body includes an elongated hollow flexible tubular member that includes a material exit port configured to allow material to exit a proximal end of the endoscopic instrument. An aspiration channel extends from the material entry port of the power-driven instrument head to a material exit port of the elongated hollow flexible tubular member. The second proximal end of the flexible portion is configured to fluidly couple to a vacuum source such that the resected material that enters the aspiration channel via the material entry port of the power-driven instrument head is removed from the endoscopic instrument via the material exit port. The endoscopic instrument is configured to travel through a tortuous instrument channel of an endoscope. In some implementations, the instrument has an outer diameter that is less than about 5 mm and wherein the flexible tubular member is at least 72 inches long.

In some implementations, the body further comprises a powered actuator, the powered actuator coupled to the first proximal end of the power-driven instrument head and configured to drive the power-driven instrument head. In some implementations, the powered actuator is an electrically powered actuator and further comprising an electrically conducting wire configured to couple to a power source. In some implementations, the aspiration channel is defined by the power-driven instrument head, the powered actuator and the flexible portion. In some implementations, the flexible tubular member defines a proximal portion of the aspiration channel.

In some implementations, the powered actuator is one of a hydraulically powered actuator or a pneumatically powered actuator, and further includes a fluid inlet tubular member configured to supply fluid to actuate the power actuator and a fluid outlet tubular member configured to remove the fluid being supplied to actuate the actuator.

In some implementations, the instrument includes an engagement assembly configured to contact the walls of the instrument channel of the endoscope when actuated. In some implementations, the engagement assembly includes a

vacuum actuated structure configured to move into an engaged position in which the vacuum actuated structure is not in contact with the instrument channel when the vacuum is actuated and configured to move into a retracted position in which the vacuum actuated structure is not in contact with the instrument channel when the vacuum is not actuated.

In some implementations, the power-driven instrument head includes an outer structure and a cutting shaft disposed within the outer structure, the cutting shaft coupled to the powered actuator and configured to rotate relative to the outer structure when the powered actuator is actuated.

In some implementations, the flexible tubular member includes a hollow flexible torque cable. The flexible torque cable has a distal region configured to couple to the first proximal end of the power-driven instrument head and has a proximal region configured to couple to a powered actuator located external to the endoscopic instrument. In some implementations, the flexible torque cable further defines a portion of the aspiration channel, wherein the distal region of the flexible torque cable is fluidly coupled to the material entry port of the power-driven instrument head and the proximal region of the flexible torque cable includes the material exit port. In some implementations, the instrument includes a sheath surrounding the flexible torque cable.

According to another aspect, a flexible endoscopic biopsy retrieval tool adapted for use with an endoscope includes a housing, a debriding component coupled to the housing, and a sample retrieval conduit disposed within the housing for retrieving debrided material that is debrided by the debriding component. In various embodiments, an improved flexible endoscope may be configured with an integrated endoscopic biopsy retrieval tool that includes a debriding component and a sample retrieval conduit for retrieving debrided material that is debrided by the debriding component.

According to another aspect, a method of retrieving polyps from a patient's body includes disposing an endoscopic instrument within an instrument channel of an endoscope, inserting the endoscope in a patient's body, actuating a debriding component of the endoscopic instrument to cut a polyp within the patient's body, and actuating a sample retrieval component of the endoscopic instrument to remove the cut polyp from within the patient's body.

According to yet another aspect, an endoscope includes a first end and a second end separated by a flexible housing. An instrument channel extends from the first end to the second end and an endoscopic instrument is coupled to the instrument channel at the first end of the endoscope. The endoscopic instrument includes a debriding component and a sample retrieval conduit partially disposed within the instrument channel.

According to yet another aspect, an endoscopic instrument insertable within a single instrument channel of an endoscope includes a cutting assembly that is configured to resect material at a site within a subject. The cutting assembly includes an outer cannula and an inner cannula disposed within the outer cannula. The outer cannula defines an opening through which material to be resected enters the cutting assembly. The endoscopic instrument also includes a flexible outer tubing coupled to the outer cannula and configured to cause the outer cannula to rotate relative to the inner cannula. The flexible outer tubing can have an outer diameter that is smaller than the instrument channel in which the endoscopic instrument is insertable. The endoscopic instrument also includes a flexible torque coil having a portion disposed within the flexible outer tubing. The flexible torque coil having a distal end coupled to the inner cannula. The flexible torque coil is configured to cause the

5

inner cannula to rotate relative to the outer cannula. The endoscopic instrument also includes a proximal connector coupled to a proximal end of the flexible torque coil and configured to engage with a drive assembly that is configured to cause the proximal connector, the flexible torque coil and the inner cannula to rotate upon actuation. The endoscopic instrument also includes an aspiration channel having an aspiration port configured to engage with a vacuum source. The aspiration channel is partially defined by an inner wall of the flexible torque coil and an inner wall of the inner cannula and extends from an opening defined in the inner cannula to the aspiration port. The endoscopic instrument also includes an irrigation channel having a first portion defined between an outer wall of the flexible torque coil and an inner wall of the flexible outer tubing and configured to carry irrigation fluid to the aspiration channel.

In some implementations, the proximal connector is hollow and an inner wall of the proximal connector defines a portion of the aspiration channel. In some implementations, the proximal connector is a rigid cylindrical structure and is configured to be positioned within a drive receptacle of the drive assembly. The proximal connector can include a coupler configured to engage with the drive assembly and a tensioning spring configured to bias the inner cannula towards a distal end of the outer cannula. In some implementations, the tensioning spring is sized and biased such that the tensioning spring causes a cutting portion of the inner cannula to be positioned adjacent to the opening of the outer cannula. In some implementations, the proximal connector is rotationally and fluidly coupled to the flexible torque coil.

In some implementations, the endoscopic instrument also includes a lavage connector including an irrigation entry port and a tubular member coupled to the lavage connector and the flexible outer tubing. An inner wall of the tubular member and the outer wall of the flexible torque coil can define a second portion of the irrigation channel that is fluidly coupled to the first portion of the irrigation channel. In some implementations, the endoscopic instrument also includes a rotational coupler coupling the flexible outer tubing to the tubular member and configured to cause the flexible outer tubing to rotate relative to the tubular member and cause the opening defined in the outer cannula to rotate relative to the inner cannula. In some implementations, the lavage connector defines an inner bore within which the flexible torque coil is disposed.

In some implementations, the endoscopic instrument also includes a lining within which the flexible torque coil is disposed, the outer wall of the lining configured to define a portion of the irrigation channel. In some implementations, the inner cannula is configured to rotate axially relative to the outer cannula and the aspiration channel is configured to provide a suction force at the opening of the inner cannula.

In some implementations, the flexible torque coil includes a plurality of threads. Each of the plurality of threads can be wound in a direction opposite to a direction in which one or more adjacent threads of the plurality of threads is wound. In some implementations, the flexible torque coil includes a plurality of layers. Each of the plurality of layers can be wound in a direction opposite to a direction in which one or more adjacent layers of the plurality of layers is wound. In some implementations, each layer can include one or more threads.

In some implementations, the flexible outer tubing has a length that exceeds the length of the endoscope in which the endoscopic instrument is insertable. In some implementations, the flexible outer tubing has a length that is at least 100

6

times larger than an outer diameter of the flexible outer tubing. In some implementations, the flexible portion is at least 40 times as long as the cutting assembly.

This Summary is provided to introduce a selection of concepts in a simplified form that are further described below in the Detailed Description. This Summary is not intended to identify key features or essential features of the claimed subject matter, nor is it intended that this Summary be used to limit the scope of the claimed subject matter. Furthermore, the claimed subject matter is not limited to implementations that offer any or all advantages or solve any or all state of the art problems.

#### BRIEF DESCRIPTION OF THE DRAWINGS

The present disclosure is illustratively shown and described in reference to the accompanying drawing in which:

FIG. 1A illustrates various types of polyps that can form within a body.

FIG. 1B illustrates a perspective partial view of an endoscope according to embodiments of the present disclosure.

FIG. 1C illustrates a perspective view of an endoscopic instrument according to embodiments of the present disclosure.

FIGS. 2A and 2B illustrate side perspective views of an endoscopic instrument coupled with the endoscope shown in FIG. 1 according to embodiments of the present disclosure.

FIGS. 3A and 3B illustrate side perspective views of an example endoscopic instrument coupled with the endoscope shown in FIG. 1 according to embodiments of the present disclosure.

FIG. 4A illustrates an exploded view of the endoscopic instrument that can be coupled with the endoscope according to embodiments of the present disclosure.

FIG. 4B illustrates a perspective view diagram of the endoscopic instrument coupled to the endoscope illustrating the various conduits associated with the endoscopic instrument.

FIG. 5 illustrates a side perspective view of another example endoscopic instrument coupled with the endoscope shown in FIG. 1 according to embodiments of the present disclosure.

FIG. 6 illustrates an enlarged view of an example endoscopic instrument according to embodiments of the present disclosure.

FIG. 7 illustrates a perspective view of an outer blade of a cutting tool of the endoscopic instrument shown in FIG. 6 according to embodiments of the present disclosure.

FIG. 8 illustrates a perspective view of an inner blade of the cutting tool of the endoscopic instrument shown in FIG. 6 according to embodiments of the present disclosure.

FIG. 9 illustrates a perspective view of a rotor of the endoscopic instrument shown in FIG. 6 according to embodiments of the present disclosure.

FIG. 10 illustrates a perspective view of a casing of the endoscopic instrument shown in FIG. 6 according to embodiments of the present disclosure.

FIG. 11 illustrates a perspective view of a cap of the endoscopic instrument shown in FIG. 6 according to embodiments of the present disclosure.

FIG. 12 illustrates a perspective view of a coupling member of the endoscopic instrument shown in FIG. 6 according to embodiments of the present disclosure.

FIG. 13 illustrates a perspective view diagram of the endoscopic instrument coupled to the endoscope illustrating the various conduits associated with the endoscopic instrument.

FIG. 14 illustrates another perspective view diagram of the endoscopic instrument coupled to the endoscope illustrating the various conduits associated with the endoscopic instrument.

FIG. 15 is a conceptual system architecture diagram illustrating various components for operating the endoscopic instrument according to embodiments of the present disclosure.

FIG. 16A illustrates an exploded view of an example endoscopic instrument according to embodiments of the present disclosure.

FIG. 16B illustrates a cross-sectional view of the endoscopic instrument shown in FIG. 16A according to embodiments of the present disclosure.

FIG. 16C illustrates a schematic view of an example engagement assembly of an example endoscopic instrument according to embodiments of the present disclosure.

FIG. 16D shows a cut-open view of the engagement assembly shown in FIG. 16C when the engagement assembly is disengaged according to embodiments of the present disclosure.

FIG. 16E shows a cut-open view of the engagement assembly shown in FIG. 16A when the engagement assembly is configured to engage with an instrument channel of an endoscope according to embodiments of the present disclosure.

FIG. 17A illustrates an exploded view of an example endoscopic instrument according to embodiments of the present disclosure.

FIG. 17B illustrates a cross-sectional view of the endoscopic instrument shown in FIG. 17A according to embodiments of the present disclosure.

FIG. 18A illustrates an exploded view of an example endoscopic instrument utilizing a tesla rotor according to embodiments of the present disclosure.

FIG. 18B illustrates a cross-sectional view of the endoscopic instrument shown in FIG. 18A according to embodiments of the present disclosure.

FIG. 19A illustrates an example endoscopic instrument that is coupled to a powered actuation and vacuum system according to embodiments of the present disclosure.

FIG. 19B illustrates a cross-section view of the powered actuation and vacuum system shown in FIG. 19A according to embodiments of the present disclosure.

FIG. 19C illustrates an exploded view of an example head portion of the endoscopic instrument shown in FIG. 19A according to embodiments of the present disclosure.

FIG. 19D illustrates a cut-open view of a portion of the endoscopic instrument having an engagement assembly according to embodiments of the present disclosure.

FIG. 19E shows a cut-open view of the engagement assembly shown in FIG. 19D in a disengaged position according to embodiments of the present disclosure.

FIG. 19F shows a cut-open view of the engagement assembly shown in FIG. 19D in an engaged position according to embodiments of the present disclosure.

FIG. 20 is a conceptual system architecture diagram illustrating various components for operating the endoscopic instrument according to embodiments of the present disclosure.

FIGS. 21A-21E illustrate aspects of an endoscopic assembly according to embodiments of the present disclosure.

FIGS. 22A-22H show various implementations of example flexible cables according to embodiments of the present disclosure.

FIGS. 23A-23B show an example implementation of a cutting tool according to embodiments of the present disclosure.

FIG. 24 illustrates various aspects of the drive shaft of the coupling component according to embodiments of the present disclosure.

FIG. 25 illustrates an example housing component according to embodiments of the present disclosure.

FIG. 26 shows an example sleeve bearing according to embodiments of the present disclosure.

FIG. 27 shows an example base plate that forms a portion of the casing according to embodiments of the present disclosure.

FIG. 28 shows an example side plate that forms a portion of the casing according to embodiments of the present disclosure.

FIGS. 29A-29E show various aspects of ferrules according to embodiments of the present disclosure.

FIGS. 30A-30C illustrate aspects of an endoscopic assembly in which the tip is press-fit according to embodiments of the present disclosure.

FIGS. 31A-31C illustrate aspects of an endoscopic assembly in which the tip is press-fit according to embodiments of the present disclosure.

FIG. 32 shows a top view of an example flexible portion of an endoscopic tool according to embodiments of the present disclosure.

FIG. 33 is a cross-sectional view of an example cutting assembly of an endoscopic tool using a torque rope according to embodiments of the present disclosure.

FIGS. 34A-34C are cross-sectional views of different configurations of the flexible portion region of one implementation of an endoscopic tool described herein.

FIG. 35 shows various views of portions of an endoscopic tool according to embodiments of the present disclosure.

FIG. 36 shows a cross-sectional view of the flexible portion region of one implementation of an endoscopic tool according to embodiments of the present disclosure.

FIG. 37 shows a cross-section view of one implementation of the endoscopic tool according to embodiments of the present disclosure.

FIG. 38 shows various views of a distal portion of one implementation of an endoscopic tool according to embodiments of the present disclosure.

FIG. 39 shows cross-sectional views of the distal portion of the endoscopic tool shown in FIG. 38 along the sections B-B and sections C-C according to embodiments of the present disclosure.

FIG. 40A shows a perspective view of an endoscopic tool and a portion of a drive assembly configured to drive the endoscopic tool according to embodiments of the present disclosure.

FIG. 40B shows a perspective view of the endoscopic tool and a perspective exposed view of the portion of the drive assembly configured to drive the endoscopic tool shown in FIG. 40A according to embodiments of the present disclosure.

FIG. 41 shows a top view of the endoscopic tool and a top exposed view of the portion of the drive assembly shown in FIGS. 40A-40B according to embodiments of the present disclosure.

FIG. 42 shows a cross-sectional view of the endoscopic tool and the portion of the drive assembly across the section A-A shown in FIG. 41 according to embodiments of the present disclosure.

FIG. 43 shows an enlarged view of the drive connector of the endoscope and the portion of the drive assembly shown in FIGS. 40A-40B according to embodiments of the present disclosure.

FIG. 44 shows a perspective view of the endoscopic tool and a portion of the drive assembly shown in FIGS. 40A-40B according to embodiments of the present disclosure.

FIG. 45 shows a cross-sectional view of the endoscopic tool and the portion of the drive assembly across the section B-B according to embodiments of the present disclosure.

FIG. 46 shows an enlarged cross-sectional view of the rotational coupler section of the endoscopic tool according to embodiments of the present disclosure.

FIG. 47A and FIG. 47B show a top view and a cross-sectional view of the rotational coupler of the endoscopic tool according to embodiments of the present disclosure.

FIG. 48 is a perspective view of a portion of the endoscopic tool inserted for operation within a drive assembly according to embodiments of the present disclosure.

FIG. 49 illustrates another implementation of the endoscopic tool and a drive assembly configured to drive the endoscopic tool according to embodiments of the present disclosure.

FIG. 50A is a side view of the endoscopic tool and drive assembly shown in FIG. 49 according to embodiments of the present disclosure.

FIG. 50B is a cross-sectional view of the endoscopic tool and drive assembly shown in FIG. 49 taken along the section A-A according to embodiments of the present disclosure.

#### DETAILED DESCRIPTION

Technologies provided herein are directed towards an improved flexible endoscopic instrument that can precisely and efficiently obtain samples of single and multiple polyps and neoplasms from a patient. In particular, the improved endoscopic instrument is capable of debriding samples from one or more polyps and retrieving the debrided samples without having to remove the endoscopic instrument from the treatment site within the patient's body.

FIG. 1A illustrates various types of polyps that can form within a body. Most polyps may be removed by snare polypectomy, though especially large polyps and/or sessile or flat polyps must be removed piecemeal with biopsy forceps or en bloc using endoscopic mucosal resection (EMR). A recent study has concluded that depressed sessile polyps had the highest rate for harboring a malignancy at 33%. The same study has also found that non-polypoid neoplastic lesions (sessile polyps) accounted for 22% of the patients with polyps or 10% of all patients undergoing colonoscopy. There are multiple roadblocks to resecting colon polyps, namely the difficulties in removing sessile polyps, the time involved in removing multiple polyps and the lack of reimbursement differential for resecting more than one polyp. Since resecting less accessible sessile polyps presents challenges and multiple polyps take more time per patient, most polyps are removed piece meal with tissue left behind as polyps increase in size, contributing to a sampling bias where the pathology of remaining tissue is unknown, leading to an increase in the false negative rate.

Colonoscopy is not a perfect screening tool. With current colonoscopy practices the endoscopist exposes the patient to sample bias through removal of the largest polyps (stalked

polyps), leaving behind less detectable and accessible sessile/flat polyps. Sessile polyps are extremely difficult or impossible to remove endoscopically with current techniques and often are left alone. An estimated 28% of stalked polyps and 60% of sessile (flat) polyps are not detected, biopsied or removed under current practice, which contributes to sample bias and a 6% false-negative rate for colonoscopy screening. Current colonoscopy instruments for polyp resection are limited by their inability to adequately remove sessile polyps and inefficiency to completely remove multiple polyps. According to the clinical literature, sessile polyps greater than 10 mm have a greater risk of malignancy. Sessile polyp fragments that are left behind after incomplete resection will grow into new polyps and carry risks for malignancy.

In the recent past, endoscopic mucosal resection (EMR) has been adopted to remove sessile polyps. EMR involves the use of an injection to elevate surrounding mucosa followed by opening of a snare to cut the polyp and lastly use of biopsy forceps or a retrieval device to remove the polyp. The introduction and removal of the injection needle and snare through the length of the colonoscope, which is approximately 5.2 feet, must be repeated for the forceps.

The present disclosure relates to an endoscopic tool that is capable of delivering an innovative alternative to existing polyp removal tools, including snares, hot biopsy and EMR, by introducing a flexible powered instrument that that works with the current generation colonoscopes and can cut and remove any polyp. The endoscopic tool described herein can be designed to enable physicians to better address sessile or large polyps as well as remove multiple polyps in significantly less time. Through the adoption of the endoscopic tool described herein, physicians can become more efficient at early diagnosis of colorectal cancer.

The present disclosure will be more completely understood through the following description, which should be read in conjunction with the drawings. In this description, like numbers refer to similar elements within various embodiments of the present disclosure. Within this description, the claims will be explained with respect to embodiments. The skilled artisan will readily appreciate that the methods, apparatus and systems described herein are merely exemplary and that variations can be made without departing from the spirit and scope of the disclosure.

Referring back to the drawings, FIG. 1B illustrates a perspective partial view of an endoscope according to embodiments of the present disclosure. Although the present disclosure is directed towards endoscopic instruments adapted for use with any type of endoscope, for sake of convenience, the teachings of the present disclosure are directed towards endoscopic instruments used with a lower GI scope, such as a colonoscope. It should, however, be appreciated that the scope of the present disclosure is not limited to endoscopic instruments for use with GI scopes, but extends to any type of flexible endoscope, including but not limited to bronchoscopes, gastroscopes and laryngoscopes, or other medical devices that may be used to treat patients.

According to various embodiments, a typical lower GI scope 100 includes a substantially flexible member that extends from a first end or head portion 102 to a second end or handle portion. The head portion 102 may be configured to swivel so as to orient a tip 104 of the head portion 102 in any direction within a hemispherical space. The handle portion has controls that allows the operator of the endoscope 100 to steer the colonoscope towards an area of

interest within the colon and turn the corners between colon segments with two steering wheels.

A series of instruments reside on the face **106** of the scope's tip **104**, including but not limited to, one or more water channels **108A-108N**, generally referred to as water channels **108**, for irrigating the area with water, one or more light sources **110A-110N**, generally referred to as light sources **110**, a camera lens **112**, and an instrument channel **120** through which an endoscopic instrument can be passed through to conduct a number of operations. The instrument channel **120** can vary in size based on the type of endoscope **100** being used. In various embodiments, the diameter of the instrument channel **120** can range from about 2 mm to 6 mm, or more specifically, from about 3.2 mm to 4.3 mm. Some larger scopes may have two instrument channels **120** so that two tools can be passed into the patient simultaneously. However, larger scopes may cause discomfort to the patient and may be too large to enter the patient's body through some of the smaller cavities.

FIG. 1C illustrates a perspective view of an endoscopic instrument **150** according to embodiments of the present disclosure. The endoscopic instrument **150** is configured to be fed through the instrument channel **120** of the endoscope **100** depicted in FIG. 1B. The endoscopic instrument **150** is configured to be inserted within an instrument channel of an endoscope, such as the instrument channel **120** of the endoscope **100** depicted in FIG. 1B. In some implementations, the portion of the endoscopic instrument **150** that is configured to be inserted within the instrument channel **120** may be sized to have an outer diameter that is smaller than the inner diameter of the instrument channel **120** of the endoscope. In some such implementations, the endoscopic instrument **150** can be sized to have an outer diameter that is sufficiently small to be slidably inserted within the instrument channel while the endoscope is coiled or bent. When the endoscope is coiled or bent, the instrument channel can form a tortuous path that includes one or more curves and bends. In one example implementations, an endoscope includes an instrument channel that has an inner diameter of about 4.3 mm when the endoscope is straightened. However, when the endoscope is coiled or bent, portions of the endoscope near the bends can have clearances that are smaller than the inner diameter of about 4.3 mm. In some implementations, the endoscope can have clearances that may be about 3.8 mm instead of the 4.3 mm achieved when the endoscope is straightened. In some implementations, the endoscope can have clearances that may be about 3.2 mm. As such, in some implementations, the endoscopic instrument **150** may be sized such that it can be slidably inserted within the instrument channel of the endoscope with which it is to be used even when the endoscope is coiled or bent.

In some implementations, the endoscopic instrument **150** includes a power-driven instrument head **160** configured to resect material at a site within a subject. The power-driven instrument head **160** has a distal end **162** and a proximal end **161**. The distal end **162** of the power-driven instrument head **160** defines a material entry port **170** through which the resected material can enter the endoscopic instrument **150**. The power-driven instrument head **160** can include a cutting section at the distal end **162** that is configured to cut tissue and other material. As used herein, a port can include any opening, aperture, or gap through which material can either enter or exit. In some implementations, the material entry port can be an opening through which resected material can enter the endoscopic instrument **150**. In some implementa-

tions, material to be resected can be suctioned into the material entry port where the instrument head can then resect the material.

A body **152** includes a head portion **155** and a flexible portion **165**. A distal end **156** of the head portion **155** of the body **152** is coupled to the proximal end **161** of the power-driven instrument head **160**. In some implementations, the head portion **155** of the body **152** is configured to drive the power-driven instrument head **160**. A proximal end **158** of the head portion **155** can be coupled to a distal end **166** of the flexible portion **165**. A proximal end **176** of the flexible portion **165** defines a material exit port **175**. The flexible portion **165** can include a hollow flexible tubular member.

The endoscopic instrument also includes an aspiration channel that extends from the material entry port **170** of the power-driven instrument head **160** to the material exit port **175** of the flexible portion **165**. In some implementations, the aspiration channel is defined by the power-driven instrument head **160**, the head portion **155** of the body **152** and the flexible portion **165** of the body. The proximal end **176** of the flexible portion **165** is configured to couple to a vacuum source such that the resected material entering the aspiration channel via the material entry port **170** is removed from the aspiration channel at the material exit port **175** while the endoscopic instrument **150** is disposed within an instrument channel of an endoscope.

The head portion **155** includes a housing that has an outer diameter that is configured such that the endoscopic instrument **150** can be slidably inserted into an instrument channel of an endoscope. In some implementations, the head portion **155** can include a powered actuator that is configured to drive the power-driven instrument head **160**. In some implementations, the powered actuator is disposed within the head portion **155**. In some implementations, the powered actuator is located external to the portion of the endoscopic instrument **150** that can be inserted into an instrument channel of an endoscope. In some implementations, the powered actuator is capable of driving the power-driven instrument head via a shaft that can translate motion generated by the power actuator to the power-driven instrument head. In some implementations, the powered actuator is not a part of the endoscopic instrument **150**, but instead, is coupled to the power-driven instrument head **160**. In some implementations, the shaft may be a flexible shaft. In some such implementations, the flexible shaft can be a flexible torque coil, additional details of which are provided below with respect to FIGS. 19A-19C.

The endoscopic instrument **150** can be sized to be insertable within an instrument channel of an endoscope. In some implementations, the endoscopic instrument **150** may be sized such that the endoscopic instrument can be inserted within the instrument channel of the endoscope while the endoscope is inserted within a subject. In some such implementations, the endoscope, for example, a colonoscope, may be curved or bent thereby requiring the endoscopic instrument **150** to be sized such that it can be inserted into a curved or bent endoscope.

In some implementations, the head portion **155** and the power-driven instrument head **160** of the endoscopic instrument **150** may be substantially stiff or rigid, while the flexible portion **165** may be relatively flexible or compliant. The head portion **155** and the power-driven instrument head **160** can be substantially rigid. As such, in some implementations, the head portion **155** and the power-driven instrument head **160** may be sized, at least in thickness and in length, such that endoscopic instrument **150** can maneuver through sharp bends and curves during insertion of the



endoscopic instrument **150** within the instrument channel of the endoscope. In some implementations, the length of the power-driven instrument head **160** may be between about 0.2"-2", about 0.2" and 1" or in some implementations, between 0.4" and 0.8". In some implementations, the outer diameter of the power-driven instrument head **160** may be between about 0.4"-1.5", 0.6" and 1.2" and 0.8" and 1". In some implementations, the length of the head portion **155** of the body may be between about 0.5"-3", about 0.8" and 2" and 1" and 1.5".

The length of the flexible portion **165** may be substantially and/or relatively longer than the length of the head portion and the power-driven instrument head **160**. In some implementations, the flexible portion **165** can be sufficiently long such that the combined length of the endoscopic instrument exceeds the length of instrument channel of an endoscope in which the instrument can be inserted. As such, the length of the flexible portion **165** may have a length that exceeds about 36", about 45" or about 60". For endoscopic instruments configured for use with other types of endoscopes, the length of the flexible portion may be shorter than 36", but still sufficiently long to allow for the body of the endoscopic instrument to be approximately the same length or greater than the length of the endoscope with which the instrument is being used.

The outer diameter of the flexible portion **165** can also be configured such that the endoscopic instrument can be inserted into the instrument channel of the endoscope. In some implementations, the outer diameter of the flexible portion **165** can be sized smaller than a corresponding inner diameter of the instrument channel of the endoscope. In some such implementations, the endoscopic instrument can be sized to have an outer diameter that is sufficiently small to be slidably disposed within the endoscope while the endoscope is coiled or bent. For example, an endoscope can include an instrument channel that has an inner diameter of about 4.3 mm when the endoscope is straightened. However, when the endoscope is coiled or bent, portions of the endoscope near the bends can have clearances that are smaller than the inner diameter of about 4.3 mm. In some implementations, the endoscope can have clearances that may be as low as 3.2 mm. As such, in some implementations, the endoscopic instrument may be sized such that the endoscopic instrument can be slidably inserted within the instrument channel of the endoscope even when the endoscope is coiled or bent.

FIGS. 2A and 2B and 3A and 3B illustrate side perspective views of an endoscopic instrument coupled with the endoscope shown in FIG. 1B according to embodiments of the present disclosure. The endoscopic instrument **220** is configured to be fed through the instrument channel **120** of the endoscope **100**. As shown in FIGS. 2A and 2B, the endoscopic instrument **220** is capable of extending outside the tip **104** of the endoscope **100**, while FIGS. 3A and 3B show that the endoscope tool **220** can be retracted within the endoscope such that no part of the endoscopic instrument **220** is extending beyond the tip **104** of the endoscope **100**. As will be described in further detail with respect to FIG. 4, the endoscopic instrument **220** is capable of cutting or debri-  
ding a polyp as well as obtaining the debri-  
ded polyp from the treatment site without having to remove the endoscopic instrument **220** from the endoscope **100**.

FIG. 4A illustrates an exploded view of the endoscopic instrument **220** adapted for use with the endoscope **100** according to embodiments of the present disclosure. The endoscopic instrument **220** includes a debri-  
ding component for debri-  
ding polyps grown in the patient's body, and a

sample retrieval component for retrieving the debri-  
ded polyps from the surgical site. The endoscopic instrument **220** includes a tubing **410** coupled to a cap **420**. In various embodiments, the cap **420** may be sealingly engaged with the tubing **410**. The cap can be aligned with a spindle **430** at a first portion of the spindle **430**. In various embodiments, the spindle **430** may be substantially hollow. The spindle **430** can be coupled to a rotor **440**, which is configured to rotate the spindle **430**. A second portion of the spindle **430** includes an inner blade **450** that may be configured to interact with an outer blade **460**. In some implementations, the outer blade **460** can be separated from the inner blade by a gap that forms an irrigation channel (not shown). A casing **470** is configured to encompass the cap **420** and the rotor **440**, as shown above with respect to FIGS. 2A and 3A. It should be appreciated that other components, such as washers, bearings, seals, and the like, may be included in the endoscopic instrument **220**.

FIG. 4B is a schematic diagram of an endoscopic instrument partially inserted within an instrument channel of an endoscopic instrument. In various embodiments, the cap, connector, rotor and casing may be made from injection molded plastic. The spindle and the cannula may be made from surgical grade steel, and the tubing may be made from silicone. However, it should be appreciated that these materials are merely examples of materials that can be used. Those skilled in the art will appreciate that other materials may be used instead of the ones described above.

The tubing **410** in FIG. 4A may be sized to pass through the instrument channel **120** of the endoscope **100** in FIGS. 4A and 4B. The tubing **410** may include one or more pneumatic fluid entry conduits **412**, one or more pneumatic fluid exit conduits **414**, one or more irrigation conduits **416**, and one or more suction conduits **418**. The pneumatic fluid entry conduits **412** are configured to supply pressurized air to pneumatically drive the rotor **440**, while the pneumatic fluid exit conduits **414** remove the air supplied by the pneumatic fluid entry conduits **412** to prevent a large amount of air from entering the patient's body. The irrigation conduits **416** supply an irrigation fluid, such as water, between the inner blade **450** and the outer blade **460** to help lubricate the area between the inner blade **450** and the outer blade **460**. In addition, the irrigation fluid then flows from the outside of the inner blade **450** to the inside portion of the inner blade **450**. It should be appreciated that the inside portion of the inner blade **450** may be aligned with the suction conduit **418** of the tubing **410** via the cap **420** such that any fluid that enters the inner blade **450** can pass through the inner blade **450** into the suction conduit **418** of the tubing **410**. The irrigation fluid that flows through the inside portion of the inner blade **450** and the suction conduit **418** helps lubricate the suction conduit **418**, through which the debri-  
ded polyps and other waste from the patient's body are removed. As described above, the tubing **410** is coupled to the cap **420** at a first end, but is coupled to one or more components at a second end (not shown). For instance, at the second end, the pneumatic air entry conduits **412** may be coupled to a compressed air source, while the irrigation fluid conduit **416** may be coupled to a water supply source. In addition, the pneumatic fluid exit conduits **414** may be coupled to the compressed air source or simply left exposed outside the patient's body for venting.

In various embodiments, the suction conduit **418** may be coupled to a disposable cartridge that is configured to catch the cut polyps and store them for examination at a later time. In various embodiments, the disposable cartridge may include multiple collection bins. The operator may be

capable of selecting the collection bin in which to collect a sample of a particular cut polyp. Upon selecting the collection bin, the suction conduit **418** supplies the collected material from within the patient's body to the particular collection bin. As such, the operator may be able to collect samples for each polyp in individual collection bins. In this way, the cancerous nature of individual polyps can be determined.

The cap **420** may be sized to fit within the first end of the tubing **410**. In various embodiments, the first end of the tubing **410** may include a connector that is configured to couple with the cap **420**. In various embodiments, the cap **420** may be press fitted into the connector of the tubing **410**. As such, the cap **420** may include corresponding conduits that match the conduits of the tubing **410**. Accordingly, compressed air from the compressed air source may be supplied through the pneumatic air entry conduits **412** of the tubing **410** and corresponding pneumatic air entry conduits of the cap **420** towards the rotor **440**. The rotor **440** may include one or more rotor blades **442** on which the compressed air is impinged thereby causing the rotor **440** to rotate. The air impinging on the rotor blades **442** may then exit through the corresponding pneumatic air exit conduits of the cap and the pneumatic air entry conduits **414** of the tubing **410**. The speed at which the rotor **440** can rotate depends on the amount of air and the pressure at which the air is supplied to the rotor **440**. In various embodiments, the speed at which the rotor **440** rotates may be controlled by the operator of the endoscope **100**. Although the present disclosure discloses pneumatic means for operating the rotor, some embodiments may include hydraulic means for operating the rotor. In such embodiments, a fluid, such as water, may be supplied in lieu of compressed air, in the pneumatic air entry conduit **412**.

As described above, the spindle **430** is coupled to the rotor **440**, such that when the rotor **440** rotates, the spindle **430** also rotates. In various embodiments, the first end of the spindle **430** includes the inner blade **450**, which correspondingly, also rotates along with the rotor **440**. The inner blade **450** may be sized to fit within the diameter of the outer blade **460**. In various embodiments, irrigation fluid supplied from an irrigation fluid source may be supplied through the irrigation fluid conduit **416** of the tubing **410** and the corresponding conduit of the cap **420**, along the space between the inner blade **450** and the outer blade **460**, and into the suction conduit **418** defined by the inner diameter of the inner blade **450**. It should be appreciated that since the suction conduit **418** is coupled to a vacuum source, fluids and other material may be suctioned through the suction conduit. In this way, the irrigation fluid is able to lubricate at least a substantial length of the suction conduit **418**, from the tip **452** of the inner blade **450**, through the spindle **430**, cap **420**, and tubing **410** into the disposable cartridge described above.

The inner blade **450** may rotate relative to the outer blade **460** such that the interaction between the inner blade **450** and the outer blade **460** causes polyps to be cut upon contact with the inner blade **450**. In various embodiments, other mechanisms for cutting polyps may be utilized, which may or may not include the use of a rotor **440**, inner blade **450** or outer blade **460**.

The debriding component may generally be configured to debride a polyp. Debriding can, for example, include any action involving detaching the polyp or a portion of the polyp from a surface of the patient's body. Accordingly, actions, including but not limited to, cutting, snaring, shredding, slicing, shattering, either entirely or partially, are also

examples of debriding. Accordingly, the debriding component may be a component that is capable of cutting, snaring, shredding, slicing, shattering, a polyp from a surface of the patient's body. As such, the debriding component may be implemented as a forceps, scissor, knife, snare, shredder, or any other component that can debride a polyp. In some embodiments, the debriding component may be manually actuated such that the debriding component may be operated through the translation of mechanical forces exerted by an operator or automatically actuated, using a turbine, electrical motor, or any other force generating component to actuate the debriding component. For instance, the debriding component may be actuated hydraulically, pneumatically, or electrically. In various embodiments, a separate conduit passing through the tubing or a channel of the endoscope may be configured to carry an electrical wire to provide power to the electrically powered actuator, such as an electrical motor.

According to various embodiments, the debriding component may include a turbine assembly, which is made up of the rotor **440**, the rotor blades **442**, and the spindle **430**. The operator may actuate the debriding component of the endoscopic instrument by supplying compressed air to the turbine assembly. When the operator is ready to begin debriding the polyp, the operator actuates the turbine assembly causing the debriding component to be actuated. In embodiments, such as the embodiment disclosed in FIG. **4**, actuating the debriding component may constitute causing the inner blade **450** to rotate relative to the outer blade **460**. Upon actuation, the operator may bring the endoscopic instrument **220** towards the polyp to be debrided causing the inner blade **450** to debride the polyp, causing portions of the debrided polyp to lie in the vicinity around the area where the polyp had grown. The operator may then de-actuate the turbine assembly and actuate suction through the suction conduit **418**. The operator may then bring the inner blade close to the cut polyp causing the cut polyp to be retrieved through the suction conduit **418**. In various embodiments, the suction component of the endoscopic instrument may be actuated while the debriding component is actuated, thereby allowing any debrided material to be retrieved by the suction component.

Although the above embodiment houses a debriding component that utilizes a turbine assembly, the scope of the present disclosure is not limited to such embodiments. Rather, it should be appreciated by those skilled in the art that the debriding component may be manually operated or may utilize any other means of debriding a polyp such that the debrided polyps are capable of being retrieved from the surgical site via the suction conduit described above. Accordingly, examples of debriding components may include, but are not limited to, snips, blades, saws, or any other sharp tools that may or may not be driven by a turbine assembly. It should be appreciated that using a debriding component that is able to cut a polyp into small enough pieces may be desirable such that the cut pieces may be retrieved via the suction conduit without having to remove the endoscopic instrument from the endoscope.

The geometry and assembly of the turbine assembly for rotating at least one of the cutting tool blades may be based on fluid dynamics. Bernoulli's equation can be used to explain the conversion between fluid pressure and the fluid velocity. According to this equation, the fluid velocity is related to the initial fluid pressure by the equation:

$$v = \sqrt{2 * \frac{P}{D}}$$

where V is Velocity, P is Pressure, and D is Mass density.

In order for the fluid to reach the calculated velocity, the fluid can be developed at the point of exit such that the channel through which the fluid is flowing meets an empirically determined L/D ratio of 2, where 'D' is the wetted diameter of the flow and the 'L' is the length of the channel.

To further understand the interaction of the rotor blades and the fluid, it is assumed that the rotor blade is made so that the air jet impinges the rotor blade on a plane. The equation of linear momentum can be applied to find the forces generated:

$$\sum F = \frac{d}{dt} \left( \int \int \int V p * dVol. \right) + \sum (\dot{m}V)_{out} - \sum (\dot{m}V)_{in}$$

where:  $\dot{m}$  is the mass flow of the impinging air jet, and V is Volume.

Assuming that the control volume remains constant (volume between blades), the force created on the blade can be solved for:

$$\Sigma F = \dot{m}(V_{out} - V_{in})$$

The quantity  $V_{out}$  and  $V_{in}$  are the same in an impulse turbine, the momentum change being created by the changing direction of the fluid only. The mass flow m is defined by the pump that is to be specified. The actual numerical value also needs to account for the velocity of the rotor. So finally, the force generated by a single blade-air jet interaction is:

$$\Sigma F = \dot{m}(V_{jet} - V_{rotor}) - (V_{jet} - V_{rotor}) \cos \theta$$

$$\Sigma F = \dot{m}(V_{jet} - V_{rotor})(1 - \cos \theta)$$

where 'θ' is the difference of the angle between the incoming air jet to that of the exiting air jet. Thought theoretically, the maximum amount of torque can be generated by a 'θ' value of 180°, but doing so will actually send the incoming jet onto the back of the following blade. Accordingly, the angle is best given a design value 15° to 20° below 180 to allow a fluid a clean exit. Finally, the force can be defined into a rotational torque:

$$\Sigma T = (\dot{m}/r)(V_{jet} - V_{rotor})(1 - \cos \theta)$$

A second force that can be considered comes from redirecting the air jet from the nozzle into the turbine wheel. To power the turbine, the air jet can be turned 90° into the direction of the blades from the direction of the air jet. The turning of the air jet will create a force on the stationary housing that is a function of the jet velocity, which in turn is proportional to the applied pressure:

$$\Sigma F = \dot{m}V_{jet}$$

This force can be reacted by the connection between the housing and the endoscope, a failure to do so can result in the ejection of the turbine assembly during operation.

Computational analyses based on Finite Element Methods (FEM) reveal that the areas where the greatest stresses are found are located near the root of the blade where a sharp corner is located. The design of air input channel can be simplified by the existing air nozzle channel in endoscope. The air nozzle in existing endoscopes directs pressurized air

across objective lens to remove moisture and also provides distension of a cavity being examined or directs pressurized water across objective lens to clear debris.

Referring now to FIG. 4B, a perspective view diagram of the endoscopic instrument coupled to the endoscope illustrating the various conduits associated with the endoscopic instrument is shown. In particular, the pneumatic air entry conduit 412 is shown supplying pressurized air to the rotor assembly, while the pneumatic air exit conduit 412 (not shown in this view) removes the air from the rotor assembly to outside the endoscope 100. The irrigation channel 416 is shown to carry irrigation fluid into the endoscopic instrument 220, where the irrigation fluid enters into the suction conduit 418, which carries material from within the patient's body to a collection component outside the endoscope. As shown in FIG. 4B, the irrigation fluid may enter the suction conduit 418 at an irrigation fluid entry opening 419. It should be appreciated that the placement of the irrigation fluid entry opening 419 may be placed anywhere along the suction conduit. Due to the suction force being applied to the suction conduit, irrigation fluid may be forced into the suction conduit without the risk of the materials flowing in the suction conduit from flowing outside the suction conduit through the irrigation fluid entry opening 419. Moreover, in some embodiments, the irrigation channel may only supply irrigation fluid to the endoscopic instrument while suction is being applied to the suction conduit.

FIG. 5 illustrates a side perspective view of another endoscopic instrument coupled with the endoscope shown in FIG. 1 according to embodiments of the present disclosure. The add-on endoscopic instrument 500 is sized to couple with the walls defining the instrument channel 120 of the tip 104 of the endoscope 100. In various embodiments, the add-on endoscopic instrument 500 may be removably attached to the instrument channel 120 of the endoscope 100 at the tip 104 of the endoscope 104 by way of an interference fit or a press fit. In other embodiments, the add-on endoscopic instrument 500 may be coupled to the endoscope 100 using other attachment means known to those skilled in the art.

Referring now to FIG. 6, an enlarged view of the add-on endoscopic instrument 500 is shown. The add-on endoscopic instrument includes an outer blade or support member 510, an inner blade 520 disposed within the outer blade 510, a rotor 530 coupled to the inner blade 520 and encompassed by a casing 540. The casing is coupled to a cap 550, which is further coupled to a connector 560. In some embodiments, the connector 560 may be sized to engage with the inner diameter of the instrument channel 120 of the endoscope 100. In some embodiments, any other component of the endoscopic instrument may be configured to engage with the endoscope 100 in such a manner as to secure the endoscopic instrument to the instrument channel 120.

FIGS. 7-12 illustrate perspective views of the individual components of the add-on endoscopic instrument shown in FIG. 6 according to embodiments of the present disclosure. In contrast to the endoscopic instrument 220 disclosed with respect to FIGS. 1-4, the add-on endoscopic instrument 500 may be adapted to fit within a first end of instrument channel 120 of the endoscope 100.

In various embodiments, a second end of the instrument channel 120 may be coupled to a vacuum source, which causes material to be suctioned through the instrument channel 120. A suction conduit extends from the vacuum source through the instrument channel of the endoscope, and further through the connector 560, the cap 550, and the rotor 530, to a first end of the inner blade 520, which has an

opening defined by the inner diameter of the inner blade **520**. It should be appreciated that the connector **560**, the cap **550**, the casing **540**, and the rotor **530** have respective center bores **566**, **556**, **546** and **536** that are aligned such that materials are allowed to flow from the opening of the inner blade **520** to the vacuum source via the second end of the instrument channel **120**.

In addition, the casing **540** of the add-on endoscopic instrument **500** includes a pneumatic air entry port **542** and a pneumatic air exit port **544** as shown in FIG. **10**. The pneumatic air entry port **542** may be adapted to receive compressed air from a compressed air source through a pneumatic air entry conduit that passes along the length of the endoscope **100** to outside the patient's body, while the pneumatic air exit port **544** may be adapted to vent air that is impinged on the rotor **530** through a pneumatic air exit conduit that passes along the length of the endoscope **100** to outside the patient's body. In this way, the rotor may be actuated by supplying compressed air from the compressed air source, as described above with respect to FIGS. **1-4**. It should be appreciated that although the rotor and associated components disclosed herein describe the use of pneumatic air, the rotor may be driven hydraulically. In such embodiments, the pneumatic air conduits may be configured to carry a liquid, such as water, to and from the area around the rotor.

Referring now also to FIG. **13**, it should be appreciated that the pneumatic air entry and exit conduits may extend from the add-on endoscopic instrument to a pneumatic air source through the instrument channel **120** of the endoscope **100**. In such embodiments, a tubing that includes separate conduits for the pneumatic air entry and exit conduits and the suction conduit may extend from outside the endoscope to the add-on endoscopic instrument within the endoscope. The tubing may be capable of being fed through the instrument channel of the endoscope and coupled to the add-on endoscopic instrument **500**. In such embodiments, the add-on endoscopic instrument **500** may be configured with an additional component that has predefined channels that couple the respective channels of the tubing with the associated with the pneumatic air entry and exit openings of the add-on endoscopic instrument and the suction conduit formed within the add-on endoscopic instrument. In addition, an irrigation fluid channel may also be defined within the tubing such that irrigation fluid may be supplied to the add-on endoscopic instrument **500**, from where the irrigation fluid is diverted into the suction conduit.

In various embodiments, the tip of the outer blade **510** may be sharp and may cause discomfort to the patient while entering a cavity of the patient's body. As such, a guard structure (not shown), such as a gel cap or other similar structure, may be attached to the outer blade prior to inserting the add-on endoscopic instrument into the patient's body to prevent injuries from the outer blade contacting a surface of the patient's body. Once the endoscopic instrument is inserted in the patient's body, the guard structure may be released from the outer blade **510**. In various embodiments, the guard structure may dissolve upon entering the patient's body.

Referring now to FIG. **14**, an improved endoscope having a built in polyp removal assembly is shown according to embodiments of the present disclosure. The improved endoscope **1400** may be similar to conventional endoscopes in many aspects, but may differ in that the improved endoscope may include a built in polyp removal assembly **1440** within an instrument channel of the endoscope **1400**. The polyp removal assembly **1440** may include a turbine assembly

having a rotor **1442** with rotor blades sealed in a casing **1444** that has one or more inlet and outlet ports for allowing either pneumatic or hydraulic fluid to actuate the rotor **1442**. The inlet ports may be designed such that the fluid may interact with the rotor blades at a suitable angle to ensure that the rotor can be driven at desired speeds.

In addition, the polyp removal assembly **1440** may be coupled to a connector **1420**, which is configured to couple the polyp removal assembly **1440** to a tubing **1470**. The tubing **1470** may include a pneumatic air entry conduit **1412**, a pneumatic air exit conduit (not shown), an irrigation fluid conduit **1416** and a suction conduit **1418** that passes through the center of the turbine assembly. The tubing **1440** may be sized such that the tubing **1440** can be securely coupled to the connector **1420** such that one or more of the conduits of the tubing **1440** are coupled to corresponding conduits within the connector **1440**. The connector **1420** may be designed to include an irrigation fluid entry opening **419**, which allows irrigation fluid to pass into the suction conduit **1418** of the tubing **1440** when the tubing is coupled to the connector.

The turbine assembly of the endoscope **1400** may be configured to couple with a removable debriding assembly **1460**, which includes a spindle and a cannula, in a manner that causes the debriding assembly to be operational when the turbine assembly is operating.

In other embodiments of the present disclosure, an endoscope may be designed to facilitate debriding one or more polyps and removing the debrided material associated with the polyps in a single operation. In various embodiments, the endoscope may include one or more separate channels for removing debrided material, supplying irrigation fluid, and supplying and removing at least one of pneumatic or hydraulic fluids. In addition, the endoscope may include a debriding component that may be fixedly or removably coupled to one end of the endoscope. In various embodiments, based on the operation of the debriding component, a separate debriding component channel may also be designed for the debriding component. In addition, the endoscope may include a light and a camera. In one embodiment, the endoscope may utilize existing channels to supply pneumatic or hydraulic fluids to the actuator of the endoscopic instrument for actuating the debriding component. For instance, in the endoscope shown in FIG. **1**, the water channels **108A-N** may be modified to supply fluids to the actuator pneumatically or hydraulically. In such embodiments, the endoscopic instrument may include a connector having a first end capable of being coupled to an opening associated with existing channels **108** of the endoscope, while another end of the connector is exposed to an opening at the actuator.

In various embodiments of the present disclosure, the endoscopic instrument may further be configured to detect the presence of certain layers of tissue. This may be useful for physicians to take extra precautions to prevent bowel perforations while debriding polyps. In some embodiments, the endoscopic instrument may be equipped with a sensor that can communicate with a sensor processing component outside the endoscope to determine the type of tissue. The sensor may gather temperature information as well as density information and provide signals corresponding to such information to the sensor processing unit, which can identify the type of tissue being sensed. In some implementations, the sensor may be an electrical sensor.

In addition, the endoscopic instrument may be equipped with an injectable dye component through which a physician may mark a particular region within the patient's body. In

other embodiments, the physician may mark a particular region utilizing the debriding component, without the use of an injectable dye.

Although the present disclosure discloses various embodiments of an endoscopic instrument, including but not limited to a tool that may be attached to the tip of the endoscope, and a tool that may be fed through the length of the endoscope, the scope of the present disclosure is not intended to be limited to such embodiments or to endoscopic instruments in general. Rather, the scope of the present disclosure extends to any device that may debride and remove polyps from within a patient's body using a single tool. As such, the scope of the present disclosure extends to improved endoscopes that may be built with some or all of the components of the endoscopic instruments described herein. For instance, an improved endoscope with an integrated turbine assembly and configured to be coupled to a debriding component is also disclosed herein. Furthermore, the endoscope may also include predefined conduits that extend through the length of the endoscope such that only the suction conduit may be defined by a disposable tubing, while the air entry and exit conduits and the irrigation conduit are permanently defined within the improved endoscope. In other embodiments, the suction conduit is also predefined but made such that the suction conduit may be cleaned and purified for use with multiple patients. Similarly, the debriding component may also be a part of the endoscope, but also capable of being cleaned and purified for use with multiple patients. Furthermore, it should be understood by those skilled in the art that any or all of the components that constitute the endoscopic instrument may be built into an existing endoscope or into a newly designed endoscope for use in debriding and removing polyps from within the patient's body.

Referring now to FIG. 15, a conceptual system architecture diagram illustrating various components for operating the endoscopic instrument according to embodiments of the present disclosure is shown. The endoscopic system 1500 includes an endoscope 100 fitted with an endoscopic instrument 220, and which may be coupled to an air supply measurement system 1510, an irrigation system 1530 and a polyp removal system 1540. As described above, the tubing that extends within the endoscope 100 may include one or more pneumatic air entry conduits 412 and one or more pneumatic air exit conduits 414. The pneumatic air entry conduits 412 are coupled to the air supply measurement system 1510, which includes one or more sensors, gauges, valves, and other components to control the amount of gas, such as air, being supplied to the endoscope 100 to drive the rotor 440. In some embodiments, the amount of air being supplied to the rotor 440 may be controlled using the air supply measurement system 1510. Furthermore, delivery of the air to actuate the rotor 440 may be manually controlled by the physician using the endoscope 100. In one embodiment, the physician may use a foot pedal or a hand-actuated lever to supply air to the rotor 440.

The pneumatic air exit conduit 414, however, may not be coupled to any component. As a result, air exiting from the rotor 440 may simply exit the endoscope via the pneumatic air exit conduit 414 into the atmosphere. In some embodiments, the pneumatic air exit conduit 414 may be coupled to the air supply measurement system 1510 such that the air exiting the pneumatic air exit conduit 414 is supplied back to the rotor via the pneumatic air entry conduit 412. It should be appreciated that a similar setup may be used for a hydraulically driven turbine system.

The endoscope 100 may also be coupled to the irrigation system 1530 via the irrigation fluid conduit 416. The irrigation system 1530 may include a flow meter 1534 coupled to an irrigation source 1532 for controlling the amount of fluid flowing from the irrigation source 1532 to the endoscope 100.

As described above, the endoscope 100 may also include a suction conduit 418 for removing polyps from within the patient's body. The suction conduit 418 may be coupled to the polyp removal system 1540, which may be configured to store the polyps. In various embodiments, the physician may be able to collect samples in one or more cartridges 1542 within the polyp removal system 1540 such that the removed polyps can be tested individually.

In various embodiments of the present disclosure, an endoscope, comprises a first end and a second end separated by a flexible housing, an instrument channel extending from the first end to the second end, and an endoscopic instrument comprising a debriding component and a sample retrieval conduit disposed within the instrument channel. The endoscopic instrument may further include a flexible tubing in which the sample retrieval conduit is partially disposed, the flexible tubing extending from the first end to the second end of the endoscope. The flexible tubing may also include a pneumatic air entry conduit and a fluid irrigation conduit. In various embodiments, the debriding component may include a turbine assembly and a cutting tool. In various embodiments in which the endoscope is configured to have a built in endoscopic instrument, the instrument channel may have a diameter that is larger than the instrument channels of existing endoscopes. In this way, larger portions of debrided material may be suctioned from within the patient's body without clogging the suction conduit.

In other embodiments, an endoscope may include a first end and a second end separated by a flexible housing; an instrument channel extending from the first end to the second end; and an endoscopic instrument coupled to the instrument channel at the first end of the endoscope, the endoscopic instrument comprising a debriding component and a sample retrieval conduit partially disposed within the instrument channel. In some embodiments, the endoscopic instrument may be removably attached to the endoscopic instrument.

In other embodiments of the present disclosure, an endoscopic system, includes an endoscope comprising a first end and a second end separated by a flexible housing and an instrument channel extending from the first end to the second end and an endoscopic instrument coupled to the instrument channel at the first end of the endoscope. The endoscopic instrument may include a debriding component and a flexible tubing having a length that is greater than the length of the endoscope. Moreover, the flexible tubing may include a sample retrieval conduit, a pneumatic air entry conduit, and a fluid irrigation conduit, a disposable cartridge configured to couple with the sample retrieval conduit proximal the second end of the endoscope, a pressurized air source configured to couple with the pneumatic air entry conduit proximal the second end of the endoscope, and a fluid irrigation source configured to couple with the fluid irrigation conduit proximal the second end of the endoscope. In various embodiments, the endoscope may also include at least one camera source and at least one light source. In some embodiments of the present disclosure, the pneumatic air entry conduit supplies pressurized air to a turbine assembly of the debriding component proximal the first end of the

endoscope and the fluid irrigation conduit supplies irrigation fluid to the sample retrieval conduit proximal the first end of the endoscope.

FIG. 16A illustrates an exploded partial view of an endoscopic instrument 1600, which is similar to the endoscopic instrument 150 depicted in FIG. 1C in that the endoscopic instrument 1600 is configured to be inserted within an instrument channel of an endoscope, such as the endoscope 100 depicted in FIG. 1B. FIG. 16B illustrates a cross-sectional partial view of the endoscopic instrument shown in FIG. 16A. As shown in FIGS. 16A and 16B, a head portion of the endoscopic instrument 1600 can include a powered actuator 1605, a power-driven instrument head 1680 including a cutting shaft 1610 and an outer structure 1615 and a feedthrough connector 1620 coupled to a distal end of a flexible tubular member 1630. The flexible tubular member 1630 forms the tail portion of the endoscopic instrument 1600. As such, FIGS. 16A and 16B illustrate the head portion of the endoscopic instrument 1600.

The endoscopic instrument 1600 is configured to define an aspiration channel 1660 that extends from a proximal end of the flexible tubular member 1630 to a distal tip 1614 of the power-driven instrument head 1680. In some implementations, the proximal end of the flexible tubular member 1630 may be configured to fluidly couple to a vacuum source. In this way, upon the application of a suction force at the proximal end of the flexible tubular member 1630, material at or around the distal tip 1614 of the power-driven instrument head 1680 can enter the endoscopic instrument 1600 at the distal tip and flow through the aspiration channel 1660 all the way to the proximal end of the flexible tubular member 1630.

The powered actuator 1605 can be configured to drive a power-driven instrument head 1680, which includes the cutting shaft 1610 disposed within the outer structure 1615. In some implementations, the powered actuator 1605 can include a drive shaft 1608 that is mechanically coupled to the cutting shaft 1610. In some implementations, one or more coupling elements may be used to couple the drive shaft 1608 to a proximal end 1611 of the cutting shaft 1610 such that the cutting shaft 1610 is driven by the drive shaft 1608. The powered actuator 1605 can be an electrically powered actuator. In some implementations, the electrically powered actuator can include an electrical terminal 1606 configured to receive an electrical conducting wire for providing electrical current to the electrically powered actuator 1605. In some implementations, the electrically powered actuator can include an electric motor. In some implementations, the electric motor can be a micro-sized motor, such that the motor has an outer diameter of less than a few millimeters. In some implementations, the powered actuator 1605 has an outer diameter that is smaller than about 3.8 mm. In addition to having a small footprint, the powered actuator 1605 may be configured to meet certain torque and rotation speed parameters. In some implementations, the powered actuator 1605 can be configured to generate enough torque and/or rotate at sufficient speeds to be able to cut tissue from within a subject. Examples of motors that meet these requirements include micromotors made by Maxon Precision Motors, Inc., located in Fall River, Mass., USA. Other examples of electrical motors include any type of electric motors, including AC motors, DC motors, piezoelectric motors, amongst others.

The power-driven instrument head 1680 is configured to couple to the powered actuator 1605 such that the powered actuator 1605 can drive the power-driven instrument head. As described above, the proximal end 1611 of the cutting

shaft 1610 can be configured to couple to the drive shaft 1608 of the powered actuator 1605. The distal end 1614 of the cutting shaft 1610 opposite the proximal end 1611 can include a cutting tip 1612. The cutting tip 1612 can include one or more sharp surfaces capable of cutting tissue. In some implementations, the cutting shaft 1610 can be hollow and can define a material entry port 1613 at or around the cutting tip 1612 through which material that is cut can enter the endoscopic instrument 1610 via the material entry port 1613. In some implementations, the proximal end 1611 of the cutting shaft 1610 can include one or more outlet holes 1614 that are sized to allow material flowing from the material entry port 1613 to exit from the cutting shaft 1610. As shown in FIGS. 16A and 16B, the outlet holes 1614 are defined within the walls of the cutting shaft 1610. In some implementations, these outlet holes 1614 can be sized such that material entering the cutting shaft 1610 via the material entry port 1613 can flow out of the cutting shaft 1610 via the outlet holes 1614. In some implementations, the portion of the cutting shaft 1610 proximal the drive shaft 1608 may be solid such that all the material that enters the cutting shaft 1610 flows out of the cutting shaft 1610 via the outlet holes 1614.

The outer structure 1615 can be hollow and configured such that the cutting shaft can be disposed within the outer structure 1615. As such, the outer structure 1615 has an inner diameter that is larger than the outer diameter of the cutting shaft 1610. In some implementations, the outer structure 1615 is sized such that the cutting shaft 1610 can rotate freely within the outer structure 1615 without touching the inner walls of the outer structure 1615. The outer structure 1615 can include an opening 1616 at a distal end 1617 of the outer structure 1615 such that when the cutting shaft 1610 is disposed within the outer structure 1615, the cutting tip 1612 and the material entry port 1613 defined in the cutting shaft 1610 is exposed. In some implementations, the outer surface of the cutting shaft 1610 and the inner surface of the outer structure 1615 can be coated with a heat-resistant coating to help reduce the generation of heat when the cutting shaft 1610 is rotating within the outer structure 1615. A proximal end of the outer structure 1615 is configured to attach to the housing that houses the powered actuator 1605.

The feedthrough connector 1620 can be positioned concentrically around the portion of the cutting shaft 1610 that defines the outlet holes 1614. In some implementations, the feedthrough connector 1620 can be hollow and configured to enclose the area around the outlet holes 1614 of the cutting shaft 1610 such that material leaving the outlet holes 1614 of the cutting shaft 1610 is contained within the feedthrough connector 1620. The feedthrough connector 1620 can include an exit port 1622, which can be configured to receive the distal end of the tubular member 1630. In this way, any material within the feedthrough connector 1620 can flow into the distal end of the flexible tubular member 1630. The feedthrough connector 1620 can serve as a fluid coupler that allows fluid communication between the cutting shaft 1610 and the tubular member 1630.

The tubular member 1630 can be configured to couple to the exit port 1622 of the feedthrough connector 1620. By way of the cutting shaft 1610, the feedthrough connector 1620 and the flexible tubular member 1630, the aspiration channel 1660 extends from the material entry port 1613 of the cutting shaft 1610 to the proximal end of the tubular member 1630. In some implementations, the tubular member 1630 can be configured to couple to a vacuum source at the proximal end of the tubular member 1630. As such, when a vacuum source applies suction at the proximal end of the tubular member

1630, material can enter the aspiration channel via the material entry port 1613 of the cutting shaft 1610 and flow through the aspiration channel 1660 towards the vacuum source and out of the endoscopic instrument 1600. In this way, the aspiration channel 1660 extends from one end of the endoscopic instrument to the other end of the endoscopic instrument 1600. In some implementations, a vacuum source can be applied to the tubular member 1630 such that the material at the treatment site can be suctioned from the treatment site, through the aspiration channel 1660 and withdrawn from the endoscopic instrument 1600, while the endoscopic instrument 1600 remains disposed within the instrument channel of the endoscope and inside the subject being treated. In some implementations, one or more of the surfaces of the cutting shaft 1610, the feedthrough connector 1620 or the tubular member 1630 can be treated to improve the flow of fluid. For example, the inner surfaces of the cutting shaft 1610, the feedthrough connector 1620 or the tubular member 1630 may be coated with a superhydrophobic material to reduce the risk of material removed from within the patient from clogging the suction conduit.

Examples of various types of instrument heads that can be coupled to the powered actuator 1605 are disclosed in U.S. Pat. Nos. 4,368,734 , 3,618,611 , 5,217,479 , 5,931,848 and U.S. Pat. Publication 2011/0087260, amongst others. In some other implementations, the instrument head can include any type of cutting tip that is capable of being driven by a powered actuator, such as the powered actuator 1650, and capable of cutting tissue into small enough pieces such that the tissue can be removed from the treatment site via the aspiration channel defined within the endoscopic instrument 1600. In some implementations, the power-driven instrument head 1680 may be configured to include a portion through which material from the treatment site can be removed. In some implementations, the circumference of the aspiration channel can be in the order of a few micrometers to a few millimeters.

In some implementations, where the powered actuator 1620 utilizes an electric current for operation, the current can be supplied via one or more conductive wires that electrically couple the powered actuator to an electrical current source. In some implementations, the electrical current source can be external to the endoscopic instrument 1600. In some implementations, the endoscopic instrument 1600 can include an energy storage component, such as a battery that is configured to supply electrical energy to the electrical actuator. In some implementations, the energy storage component can be positioned within the endoscopic instrument. In some implementations, the energy storage component or other power source may be configured to supply sufficient current to the powered actuator that cause the powered actuator to generate the desired amount of torque and/or speed to enable the cutting shaft 1610 to cut tissue material. In some implementations, the amount of torque that may be sufficient to cut tissue can be greater than or equal to about 2.5 N mm. In some implementations, the speed of rotation of the cutting shaft can be between 1000 and 5000 rpm. However, these torque ranges and speed ranges are examples and are not intended to be limiting in any manner.

The endoscopic instrument 1600 can include other components or elements, such as seals 1640 and bearings 1625, which are shown. In some implementations, the endoscopic instrument 1600 can include other components that are not shown herein but may be included in the endoscopic instrument 1600. Examples of such components can include sensors, cables, wires, as well as other components, for

example, components for engaging with the inner wall of the instrument channel of an endoscope within which the endoscopic instrument can be inserted. In addition, the endoscopic instrument can include a housing that encases one or more of the powered actuator, the feedthrough connector 1620, any other components of the endoscopic instrument 1600. In some implementations, the tail portion of the endoscopic instrument 1600 can also include a flexible housing, similar to the flexible portion 165 shown in FIG. 1C, that can carry one or more flexible tubular members, such as the flexible tubular member 1630, as well as any other wires, cables or other components.

In some implementations, the endoscopic instrument can be configured to engage with the instrument channel of an endoscope in which the instrument is inserted. In some implementations, an outer surface of the head portion of the endoscopic instrument can engage with an inner wall of the instrument channel of the endoscope such that the endoscopic instrument does not experience any unnecessary or undesirable movements that may occur if endoscopic instrument is not supported by the instrument channel. In some implementations, the head portion of the body of the endoscopic instrument can include a securing mechanism that secures the head portion of the body to the inner wall of the instrument channel. In some implementations, the securing mechanism can include deploying a frictional element that engages with the inner wall. The frictional element can be a seal, an o-ring, a clip, amongst others.

FIG. 16C illustrates a schematic view of an engagement assembly of an example endoscopic instrument. FIG. 16D shows a cut-open view of the engagement assembly when the engagement assembly is disengaged. FIG. 16E shows a cut-open view of the engagement assembly when the engagement assembly is configured to engage with an instrument channel of an endoscope. As shown in FIGS. 16C and 16D, the engagement assembly 1650 includes a housing portion 1652 that defines a cylindrical groove 1654 around an outer surface 1656 of the housing portion. The groove 1654 is sized such that a compliant seal component 1670 can be partially seated within the groove 1654. A cylindrical actuation member 1660 is configured to encompass the housing portion 1652. The cylindrical actuation member 1660 can slidably move along the length of the housing portion 1652. The cylindrical actuation member 1660 is configured to engage the securing member 1670 by pressing on the surface of the securing member 1670. The actuation member 1660 can apply a force on the securing member 1670 causing the securing member 1670 to deform such that the securing member 1670 becomes flatter and wider. The securing member 1670 is configured such that when the securing member 1670 widens, the outer surface of the securing member 1670 can engage with an inner surface of the instrument channel of an endoscope in which the endoscopic instrument is inserted. In this way, when the cylindrical actuation member 1660 is actuated, the endoscopic instrument 1600 can engage with the instrument channel thereby preventing the endoscopic instrument 1600 from moving relative to the instrument channel. This can help provide stability to the operator while treating the subject. In some implementations, more than one engagement assembly 1650 can be positioned along various portions of the endoscopic instrument 1600.

FIG. 17A illustrates an exploded view of an example endoscopic instrument 1700 according to embodiments of the present disclosure. FIG. 17B illustrates a cross-sectional view of the endoscopic instrument 1700. The endoscopic instrument 1700, similar to the endoscopic instrument 1600

shown in FIGS. 16A and 16B, can also be configured to be inserted within an instrument channel of an endoscope, such as the endoscope 100 depicted in FIG. 1B. The endoscopic instrument 1700, however, differs from the endoscopic instrument 1600 in that the endoscopic instrument 1700 defines an aspiration channel 1760 that extends through a powered actuator 1705. In this way, material entering a material entry port 1713 of the endoscopic instrument 1700 can flow through the endoscopic instrument 1700 and out of the endoscopic instrument in a straight line.

As shown in FIGS. 17A and 17B, the endoscopic instrument 1700 is similar to the endoscopic instrument 1600 except that the endoscopic instrument includes a different powered actuator 1705, a different cutting shaft 1710 and a different feedthrough connector 1720. The powered actuator 1705 is similar to the powered actuator 1605 shown in FIG. 16A but differs in that the powered actuator 1705 includes a drive shaft 1708 that is hollow and extends through the length of the powered actuator 1705. Since some of the components are different, the manner in which the endoscopic instrument is assembled is also different.

In some implementations, the powered actuator 1605 can be any actuator capable of having a hollow shaft that extends through the length of the motor. The distal end 1708a of the drive shaft 1708 includes a first opening and is coupled to the proximal end 1711 of the cutting shaft 1705. Unlike the cutting shaft 1610, the cutting shaft 1710 includes a fluid outlet hole 1714 at the bottom of the cutting shaft 1710. As a result, the entire length of the cutting shaft 1710 is hollow. The proximal end 1708b of the drive shaft 1708 is configured to couple to the feedthrough connector 1720, which differs from the feedthrough connector 1620 in that the feedthrough connector 1720 includes a hollow bore 1722 defining a channel in line with the proximal end of the drive shaft such that the drive shaft 1708 and the hollow bore 1722 are fluidly coupled. The hollow bore 1722 can be configured to couple to the flexible tubular member 1730, which like the flexible tubular member 1630, extends from the feedthrough connector at a distal end to a proximal end that is configured to couple to a vacuum source.

As shown in FIGS. 17A and 17B, the drive shaft 1708 can be hollow, such that the drive shaft 1708 defines a first opening at a distal end 1708a and a second opening at a proximal end 1708b of the drive shaft 1708. The cutting shaft 1710 is also hollow and defines an opening 1714 at the bottom end 1710a of the cutting shaft 1710. The distal end 1708a of the drive shaft 1708 is configured to couple to the bottom end 1710a of the cutting shaft 1710 such that the first opening of the drive shaft 1708 is aligned with the opening at the bottom end 1710a of the cutting shaft 1710. In this way, the drive shaft 1708 can be fluidly coupled to the cutting shaft 1710. A distal end 1710b of the cutting shaft 1710 includes a cutting tip 1712 and the material entry port 1713.

The proximal end 1708a of the drive shaft 1708 is fluidly coupled to a distal end of the flexible tubular member 1730 via the feedthrough connector 1720. In some implementations, the feedthrough connector 1720 couples the drive shaft and the flexible tubular member such that the flexible tubular member does not rotate with the drive shaft. The proximal end of the flexible tubular member can be configured to couple to a vacuum source.

As shown in FIG. 17B, the endoscopic instrument 1700 defines an aspiration channel 1760 that extends from the material entry port 1713 through the cutting shaft, the drive shaft, the feedthrough connector 1720 to the second end of the flexible tubular member 1730. In this way, material that

enters the material entry port 1713 can flow through the length of the endoscopic instrument and exit from the endoscopic instrument at the second end of the endoscopic instrument.

Other components of the endoscopic instrument 1700 are similar to those shown in the endoscopic instrument 1600 depicted in FIGS. 16A and 16B. For example, the outer structure 1715, the encoding component 1606, the seals and the bearings may be substantially similar to the outer structure 1615, the encoding component 1606, the seals 1640 and the bearings 1625 depicted in FIG. 16. Other components, some of which are shown, may be included to construct the endoscopic instrument and for proper functioning of the instrument.

FIG. 18A illustrates an exploded view of an example endoscopic instrument 1800 according to embodiments of the present disclosure. FIG. 18B illustrates a cross-sectional view of the endoscopic instrument 1800. The endoscopic instrument 1800, similar to the endoscopic instrument 1700 shown in FIGS. 17A and 17B, can also be configured to be inserted within an instrument channel of an endoscope, such as the endoscope 100 depicted in FIG. 1B. The endoscopic instrument 1800, however, differs from the endoscopic instrument 1700 in that the endoscopic instrument 1800 includes a pneumatic or hydraulically powered actuator 1805.

In some implementations, the powered actuator 1802 includes a tesla turbine that includes a tesla rotor 1805, a housing 1806 and a connector 1830 that along with the housing 1806 encases the tesla rotor 1805. The tesla rotor 1805 can include a plurality of disks 1807 spaced apart and sized such that the tesla rotor 1805 fits within the housing. In some implementations, the tesla rotor can include between 7 and 13 disks having a diameter between about 2.5 mm and 3.5 mm and thicknesses between 0.5 mm to 1.5 mm. In some implementations, the disks are separated by gaps that range from 0.2 mm to 1 mm. The tesla turbine 1802 also can include a hollow drive shaft 1808 that extends along a center of the tesla rotor 1805. In some implementations, a distal end 1808a of the drive shaft 1808 is configured to be coupled to a cutting shaft 1810 such that the cutting shaft 1810 is driven by the tesla rotor. That is, in some implementations, the cutting shaft 1810 rotates as the drive shaft 1808 of the tesla rotor 1805 is rotating. In some implementations, the cutting shaft 1810 can include outlet holes similar to the cutting shaft 1610 shown in FIG. 16A. In some such implementations, the feedthrough connector fluidly couples the cutting shaft and the flexible portion similar to the feedthrough connector 1630 shown in FIG. 16A.

The connector 1830 of the tesla turbine 1802 can include at least one fluid inlet port 1832 and at least one fluid outlet port 1834. In some implementations, the fluid inlet port 1832 and the fluid outlet port 1834 are configured such that fluid can enter the tesla turbine 1802 via the fluid inlet port 1832, cause the tesla rotor 1805 to rotate, and exit the tesla turbine 1802 via the fluid outlet port 1834. In some implementations, the fluid inlet port 1832 is fluidly coupled to a fluid inlet tubular member 1842 configured to supply fluid to the tesla rotor via the fluid inlet port 1832. The fluid outlet port 1834 is fluidly coupled to a fluid outlet tubular member 1844 and configured to remove the fluid supplied to the tesla turbine 1802. The amount of fluid being supplied and removed from the tesla turbine 1802 can be configured such that the tesla rotor 1805 can generate sufficient torque, while rotating at a sufficient speed to cause the cutting shaft 1810 to cut tissue at a treatment site. In some implementations, the fluid can be air or any other suitable gas. In some other



implementations, the fluid can be any suitable liquid, such as water. Additional details related to how fluid can be supplied or removed from pneumatic or hydraulic actuators, such as the tesla turbine **1802** has been described above with respect to FIGS. **4A-15**.

The connector **1830** also includes a suction port **1836** that is configured to couple to an opening defined at a proximal end **1808b** of the hollow drive shaft **1808**. The suction port **1836** is further configured to couple to a distal end of a flexible tubular member **1846**, similar to the flexible tubular member **1730** shown in FIG. **17A**, which is configured to couple to a vacuum source at a proximal end. In some implementations, a flexible tubular housing can include one or more of the fluid inlet tubular member **184**, fluid outlet tubular member **1844** and the flexible tubular member **1846**. In some implementations, the flexible tubular housing can include other tubular members and components that extend from the head portion of the endoscopic instrument to the proximal end of the tail portion of the endoscopic instrument **1800**.

The cutting shaft **1810** and an outer structure **1815** are similar to the cutting shaft **1710** and the outer structure **1715** of the endoscopic instrument **1700** depicted in FIG. **17A**. The cutting shaft **1810** is hollow and defines an opening at a proximal end **1810b** of the cutting shaft **1810**. The proximal end **1810b** of the cutting shaft **1810** is configured to couple to a distal end **1808a** of the drive shaft **1808** such that an opening at the distal end **1808a** of the drive shaft **1808** is aligned with the opening defined at the proximal end **1808b** of the cutting shaft **1810**. In this way, the drive shaft **1808** can be fluidly coupled to the cutting shaft **1810**. A distal end **1810b** of the cutting shaft **1810** includes a cutting tip **1812** and a material entry port **1813** similar to the cutting shafts **1610** and **1710** shown in FIGS. **16A** and **17A**.

In some implementations, an irrigation opening **1852** can be formed in the housing **1806**. The irrigation opening **1852** is configured to be fluidly coupled to the aspiration channel **1860**. In some such implementations, the irrigation opening **1852** is configured to be fluidly coupled to a gap (not clearly visible) that separates the walls of outer structure **1815** and the cutting shaft **1810**. In this way, fluid supplied to the tesla turbine **1802** can escape via the irrigation opening **1852** in to the gap. The fluid can flow towards the material entry port **1813** of the cutting shaft **1810**, through which the fluid can enter the aspiration channel **1860**. In some implementations, since the aspiration channel **1860** is fluidly coupled to a vacuum source, the fluid from the tesla turbine **1802** can be directed to flow through the aspiration channel **1860** as irrigation fluid along with any other material near the material entry port **1813**. In this way, the irrigation fluid can irrigate the aspiration channel **1860** to reduce the risk of blockages.

In addition, as the irrigation fluid flows in the gap separating the outer structure **1815** and the cutting shaft **1810**, the irrigation fluid can serve to reduce the generation of heat. In some implementations, one or both of the cutting shaft **1810** and the outer structure **1815** can be coated with a heat-resistant layer to prevent the cutting shaft and the outer structure from getting hot. In some implementations, one or both of the cutting shaft **1810** and the outer structure **1815** can be surrounded by a heat-resistant sleeve to prevent the cutting shaft **1810** and the outer structure **1815** from getting hot.

In some implementations, other types of hydraulically or pneumatically powered actuators can be utilized in place of the tesla turbine. In some implementations, a multi-vane rotor can be used. In some such implementations, the

powered actuator can be configured to be fluidly coupled to a fluid inlet tubular member and a fluid outlet tubular member similar to the tubular members **1842** and **1844** shown in FIG. **18B**.

As described above with respect to the endoscopic instruments **1600**, **1700** and **1800** depicted in FIGS. **16A**, **17A** and **18A**, an endoscopic instrument is configured to meet certain size requirements. In particular, the endoscopic instrument can be long enough such that when the endoscopic instrument is completely inserted into the endoscope, the power-driven instrument head can extend beyond the face of the endoscope at one end such that the cutting tip is exposed, while the tail portion of the endoscopic instrument can extend out of the other end of the endoscope such that the tail portion can be coupled to a vacuum source. As such, in some implementations, the endoscopic instrument may be configured to be longer than the endoscopes in to which the endoscopic instrument will be inserted. Further, since endoscopes have instrument channels that have different diameters, the endoscopic instrument may also be configured to have an outer diameter that is sufficiently small such that the endoscopic instrument can be inserted into the instrument channel of the endoscope in to which the endoscopic instrument will be inserted.

Some endoscopes, such as colonoscopes, can have instrument channels that have an inner diameter that can be as small as a few millimeters. In some implementations, the outer diameter of the endoscopic instrument can be less than about 3.2 mm. As such, powered actuators that are part of the endoscopic instrument may be configured to have an outer diameter that is less than the outer diameter of the endoscopic instrument. At the same time, the powered actuators may be configured to be able to generate sufficient amounts of torque, while rotating at speeds sufficient to cut tissue at a treatment site within a subject.

In some other implementations, the endoscopic instrument can be configured such that a powered actuator is not housed within the endoscopic instrument at all or at least within a portion of the endoscopic instrument that can be inserted within the instrument channel of an endoscope. Rather, the endoscopic instrument includes a flexible cable that is configured to couple a power-driven instrument head of the endoscopic instrument to a powered actuator that is located outside of the endoscope.

FIG. **19A** illustrates an example endoscopic instrument **1900** that is coupled to a powered actuation and vacuum system **1980**. The endoscopic instrument includes a head portion **1902** and a tail portion. The tail portion includes the flexible cable **1920**, which can provide torque to the head portion **1902**. The powered actuation and vacuum system **1980** includes a powered actuator **1925**, a coupler **1935** and a vacuum tubing **1930** configured to couple to the couple **1935** at a first end **1932** and couple to a vacuum source at a second end **1934**. In some implementations, the flexible cable **1920** can be hollow and configured to carry fluid from the head portion **1902** to the coupler **1935**.

FIG. **19B** illustrates a cross-section view of the powered actuation and vacuum system **1980** of FIG. **19A**. The powered actuator **1925** includes a drive shaft **1926** that is mechanically coupled to a proximal end **1922** of the flexible cable **1920**. In some implementations, the drive shaft **1926** and the flexible cable **1920** are mechanically coupled via the coupler **1935**. The coupler **1935** includes a vacuum port **1936** to which a first end **1932** of the vacuum tubing **1930** can be fluidly coupled. The coupler **1935** can be enclosed such that the vacuum tubing **1930** and the flexible cable are fluidly coupled. In this way, suction applied in the vacuum

tubing **1930** can be applied all the way through the flexible cable **1920** to the head portion **1902** of the endoscopic instrument **1900**. Further, any material that is in the flexible cable **1920** can flow through the flexible cable to the vacuum tubing **1930** via the coupler **1935**. In some implementations, the coupling between the flexible cable and the vacuum tubing can occur within the head portion **1902**. In such implementations, the coupler **1935** may be configured to be small enough to be positioned within the head portion **1902**.

FIG. **19C** illustrates an exploded view of an example head portion of the endoscopic instrument **1900** shown in FIG. **19A**. The head portion includes a housing cap **1952**, a collet **1954**, a cutting shaft **1956**, a shaft coupler **1958** and a head portion housing **1960**. In some implementations, the collet **1954** is slightly tapered towards a distal end such that the collet **1954** can couple with the cutting shaft **1956** that is disposed within the collet **1954**. The shaft coupler **1958** is configured to couple the cutting shaft to the distal end of the flexible cable **1920**. The head portion **1960** and the housing cap **1952** are configured to house the shaft coupler **1958**.

FIG. **19D** illustrates a cut-open view of a portion of the endoscopic instrument **1900** having an engagement assembly. In some implementations, the head portion housing **1960** can include an engagement assembly for engaging with the inner walls of an instrument channel. The engagement assembly can be similar to the engagement assembly **1650** shown in FIG. **16C**. In some implementations, the engagement assembly can be actuated via a vacuum source. FIG. **19E** shows a cut-open view of the engagement assembly shown in FIG. **19D** in a disengaged position. FIG. **19F** shows a cut-open view of the engagement assembly shown in FIG. **19D** in an engaged position.

The engagement assembly can include a pair of vacuum actuated members **1962** that are configured to rotate between an extended position in which the members **1962** are extended outwardly to engage with a wall of the instrument channel **1990** and a retracted position in which the members **1962** are positioned such that they lie substantially parallel to the walls of the instrument channel **1990**. The grooves **1964** are fluidly coupled to an aspiration channel **1970** defined within the flexible cable **1920**. In some implementations, fluid channels **1966** fluidly couple the grooves **1964** to the aspiration channel **1970**. When a vacuum source is applied to the aspiration channel **1970**, a suction force is applied to the members **1962** causing them to move from a retracted position (as shown in FIG. **19E**) to an extended position (as shown in FIG. **19F**). In some implementations, the engagement assembly can also include an outer ring supported by the vacuum actuated members **1964**. The outer ring **1966** can be configured to assist in guiding the endoscopic instrument through the instrument channel of the endoscope. In particular, the outer ring can prevent the endoscopic instrument from tilting to one side causing the power-driven instrument head from jarring against the instrument channel.

The endoscopic instrument **1900** is similar to the endoscopic instruments **1600**, **1700** and **1800** depicted in FIGS. **16A-18A** respectively but differs from them in that the endoscopic instrument **1900** does not include a powered actuator within the head portion **1902** of the endoscopic instrument **1900**. Instead, the endoscopic instrument **1900** includes a flexible cable **1920** for providing torque to a power-driven instrument head **1904** of the endoscopic instrument **1900**. In some implementations, the power-driven instrument head **1904** can be similar to the power-driven instrument heads depicted in FIGS. **16A-18A**. In some implementations, the flexible cable **1920** can be hol-

low such that fluid can flow through the flexible cable **1920**. In some such implementations, a proximal end **1922** of the flexible cable **1920** can be configured to couple to a vacuum source, while a distal end **1921** of the flexible cable **1920** can be coupled to the power-driven instrument head **1904**. In this way, fluid that enters a material entry port **1907** can flow through the power-driven instrument head **1904** and into the flexible cable **1920**, from which the fluid can flow through the flexible cable **1920** and be removed from the endoscopic instrument **1900** at the proximal end **1922** of the flexible cable **1920**.

In some implementations, a flexible cable, such as the flexible cable **1920** can replace a powered actuator and drive shaft that are housed within an endoscopic instrument. For example, the endoscopic instruments **1600**, **1700** and **1800** depicted in FIGS. **16A**, **17A** and **18A** can be configured to utilize a flexible cable that is coupled to a cutting shaft of a power-driven instrument head at a distal end and coupled to a powered actuator located outside the endoscopic instrument at a proximal end. The powered actuator located outside the endoscopic instrument may be significantly larger than the powered actuators **1605**, **1705** or **1805**. As the powered actuator is actuated, torque generated by the powered actuator can be translated from the powered actuator to the power-driven instrument head via the flexible cable. The flexible cable **1920** is configured to translate torque from the powered actuator to the cutting shaft. In some implementations, the flexible cable **1920** is or includes a fine coil with multiple threads and multiple layers, which can transmit the rotation of one end of the flexible cable to an opposite end of the flexible cable. The flexibility of the cable allows the coil to maintain performance even in sections of the coil that are bent. Examples of the flexible cable **1920** include torque coils made by ASAHI INTECC USA, INC located in Santa Ana, Calif., USA. In some implementations, the flexible cable **1920** can be surrounded by a sheath to avoid frictional contact between the outer surface of the flexible cable and other surfaces. In some implementations, the flexible cable **1920** can be coated with Polytetrafluoroethylene (PTFE) to reduce frictional contact between the outer surface of the flexible cable and other surfaces.

FIG. **20** is a conceptual system architecture diagram illustrating various components for operating the endoscopic instrument according to embodiments of the present disclosure. The endoscopic system **2000** includes an endoscope **100** fitted with an endoscopic instrument **2002** that includes a flexible tail portion **2004**. The endoscopic instrument can, for example, be the endoscopic instrument **220**, **1600**, **1700**, **1800** or **1900** shown in FIGS. **4A-14**, **16A**, **17A**, **18A** and **19A**. The system also includes an endoscope control unit **2005** that controls the operation of the endoscope **100** and an instrument control unit **2010** that controls the operation of the endoscopic instrument **2002**.

In addition, the endoscopic instrument also includes a vacuum source **1990**, a sample collection unit **2030** and a tissue sensing module **2040**. The vacuum source **1990** is configured to fluidly couple to a flexible tubular member that forms a portion of the aspiration channel. In this way, material that flows from the endoscopic instrument through the aspiration channel towards the vacuum source **1990** can get collected at **2030** sample collection unit. The tissue sensing module can be communicatively coupled to a tissue sensor disposed at a distal tip of the endoscopic instrument **2000**. In some such implementations, the tissue sensing module can also be configured to be communicatively coupled to the instrument control unit **2010** such that the

tissue sensing module can send one or more signals instructing the control unit **2010** to stop the actuation of the powered actuator.

In some implementations in which the powered actuator is electrically actuated and disposed within the endoscopic instrument, the powered actuator can be electrically coupled to the instrument control unit **2010**. In some such implementations, the powered actuator is coupled to the control unit via one or more electric cables. In some implementations, the powered actuator may be battery operated in which case, the tubing may include cables extending from the control unit to the powered actuator or the battery for actuating the powered actuator.

In some implementations in which the power-driven instrument head is coupled to a flexible torque coil that couples the power-driven instrument head to a powered actuator that resides outside of the endoscope, the powered actuator can be a part of the instrument control unit.

In various embodiments of the present disclosure, an endoscope, comprises a first end and a second end separated by a flexible housing, an instrument channel extending from the first end to the second end, and an endoscopic instrument comprising a debriding component and a sample retrieval conduit disposed within the instrument channel. The endoscopic instrument may further include a flexible tubing in which the sample retrieval conduit is partially disposed, the flexible tubing extending from the first end to the second end of the endoscope. The flexible tubing may also include a pneumatic air entry conduit and a fluid irrigation conduit. In various embodiments, the debriding component may include a turbine assembly and a cutting tool. In various embodiments in which the endoscope is configured to have a built in endoscopic instrument, the instrument channel may have a diameter that is larger than the instrument channels of existing endoscopes. In this way, larger portions of debrided material may be suctioned from within the patient's body without clogging the suction conduit.

In other embodiments, an endoscope may include a first end and a second end separated by a flexible housing; an instrument channel extending from the first end to the second end; and an endoscopic instrument coupled to the instrument channel at the first end of the endoscope, the endoscopic instrument comprising a debriding component and a sample retrieval conduit partially disposed within the instrument channel. In some embodiments, the endoscopic instrument may be removably attached to the endoscopic instrument.

In other embodiments of the present disclosure, an endoscopic system, includes an endoscope comprising a first end and a second end separated by a flexible housing and an instrument channel extending from the first end to the second end and an endoscopic instrument coupled to the instrument channel at the first end of the endoscope. The endoscopic instrument may include a debriding component and a flexible tubing having a length that is greater than the length of the endoscope. Moreover, the flexible tubing may include a sample retrieval conduit, a pneumatic air entry conduit, and a fluid irrigation conduit, a disposable cartridge configured to couple with the sample retrieval conduit proximal the second end of the endoscope, a pressurized air source configured to couple with the pneumatic air entry conduit proximal the second end of the endoscope, and a fluid irrigation source configured to couple with the fluid irrigation conduit proximal the second end of the endoscope. In various embodiments, the endoscope may also include at least one camera source and at least one light source. In some embodiments of the present disclosure, the pneumatic

air entry conduit supplies pressurized air to a turbine assembly of the debriding component proximal the first end of the endoscope and the fluid irrigation conduit supplies irrigation fluid to the sample retrieval conduit proximal the first end of the endoscope.

As described above with respect to FIGS. **19A-19C**, the endoscopic tool can include a flexible cable that can be configured to be driven by a powered actuator that resides outside the endoscopic tool itself. The flexible cable can be a torque coil or rope.

FIGS. **21A-21E** illustrate aspects of an endoscopic assembly. In particular, FIGS. **21A-21E** illustrate various views of an endoscopic tool **2110** coupled to a powered actuator **2120** encased in a housing **2150**. As shown in FIG. **21**, the powered actuator **2120** can be a motor that is operatively coupled to a flexible cable via a pulley system. A casing **2150** including one or more structures, such as a base plate **2152**, one or more side plates **2154** and a top plate **2156** can encase the motor **2120**. A coupling component **2130** can be configured to couple the flexible cable **2114** to the motor **2120**, while providing a suction mechanism to remove any fluids passing through the endoscopic tool **2110**. The coupling component **2130** can include a suction port **2170** through which fluid within the endoscopic tool **2110** can be removed and collected. In FIG. **21B**, a pair of pulleys **2160** and **2162** coupled to a timing belt **2164** are configured such that rotational energy from the motor is transferred to one end of the flexible cable **2114**. The other end of the flexible cable **2114** can be coupled to a cutting member **2112**. Additional details regarding the flexible cable **2114** are described herein with respect to FIGS. **22A-22H**.

FIGS. **22A-22H** show various implementations of example flexible cables. In some implementations, the flexible cable can be made of three separate threads or wires. An inner wire can have a left-hand wound, a middle wire can have a right-hand wound and the outer wire can have a left-hand wound. In some implementations, the inner wire can have a right-hand wound, a middle wire can have a left-hand wound and the outer wire can have a right-hand wound. In some implementations, the flexible cable can be made of two separate threads or wires. In some such implementations, the inner wire can have a left-hand wound and the outer wire can have a right-hand wound. In some other implementations, the inner wire can have a right-hand wound and the outer wire can have a left-hand wound. In some implementations, the wire rope strands can be twisted in either Z-lay or S-lay. Examples of flexible cables include wire ropes and torque coils manufactured by ASAHI INTECC. In some implementations, the outer diameter of the torque rope or coil is limited by the size of the working channel of the endoscope with which the endoscopic tool will be used. Other size considerations that need to be taken into account include providing enough space for the aspiration channel, irrigation channel, amongst others. In some implementations, the outer diameter of the torque coil or torque rope can range between 0.1 mm and 4 mm. In some implementations, the torque coil or rope can have an outer diameter of 0.5 mm to 2.0 mm.

Referring back to FIG. **21D**, a cross-sectional view of the coupling component **2130** is shown. The coupling component **2130** couples one end of the endoscopic tool to the powered actuator **2120** via the pulleys **2160** and **2162** and to the suction port **2170**. The coupling component includes a collection chamber **2181**, which is where fluid within the aspirating tube **2118** of the endoscopic tool **2110** can be collected before being suctioned out from the coupling component **2130**. The coupling component includes a col-

lection chamber **2181** can also include a drive shaft **2186** that is configured to engage with the pulley **2162**. The flexible cable or torque rope **2114** can be coupled to one end of the drive shaft **2186**. An opposite end of the drive shaft **2186** is coupled to the pulley **2162**, such that the drive shaft is operatively coupled with the motor **2120**. In this way, as the motor rotates, the pulleys and the timing belt **2164** are configured to rotate the drive shaft **2186**, and in turn, the torque rope **2114**. FIG. **24** illustrates various aspects of the drive shaft of the coupling component **2130**. As shown in FIG. **24**, the drive shaft **2186** can be configured to receive one end of the flexible cable via an opening **2406**. A pair of holes **2402a** and **2402b** can be configured to receive set screws or other securing members for securing the flexible cable to the drive shaft **2186**.

The coupling component **2130** also includes a housing component **2500** that couples a flexible portion of the endoscopic tool to the suction port **2170** via an opening **2502**. FIG. **25** illustrates an example housing component **2500**.

FIG. **26** shows an example sleeve bearing.

FIG. **27** shows an example base plate **2152** that forms a portion of the casing. FIG. **28** shows an example side plate that forms a portion of the casing. The side plate can also serve as a feedthrough mount.

In some implementations, the coupling component is a part of the endoscopic tool. In some implementations, the coupling component is coupled to a flexible portion of the endoscopic tool via a compression fitting component **2182**.

The flexible portion of the endoscopic tool includes an outer tubing, which includes an aspiration tube **2118**, the torque rope **2114** and a sheath **2116** that surrounds the outer circumference of the torque rope **2114**. The sheath can help reduce friction or the formation of kinks. The aspiration tube **2118** is configured to couple to a cutting tool **2190** such that material that enters into the cutting tool **2190** via an opening **2193** can pass through the length of the endoscopic tool **2110** via the aspiration tube **2118**.

As shown in FIG. **21E**, the torque rope is configured to be coupled to an inner cannula **2192** that forms a portion of the cutting tool. The inner cannula **2192** can be surrounded by or disposed within the outer cannula **2191**. The opening **2193** is formed within the outer cannula **2191** at one end of the cutting tool **2190**. Details of the cutting tool **2190** have been provided herein. FIGS. **23A-23B** show an example implementation of a cutting tool. The cutting tool can be any type of cutting tool used in existing medical devices. The cutting tool shown in FIGS. **23A-23B** are shown only for the sake of example and the present disclosure is not intended to be limited to such sizes, shapes, or dimension. Commercially available cutting tools can be used. In some implementations, the cutting tools can be modified in length. In some implementations, the inner cannula can be bonded to the ferrule, while the outer cannula can be coupled to the outer aspirating tube. In some implementations, the connection between the outer cannula and the aspiration channel may be sealed to prevent material from leaking through the connection.

In some implementations, the torque rope **2114** is coupled to the inner cannula **2192** via a ferrule **2194**. The ferrule can be a component that couples the torque rope to the inner cannula such that rotational energy within the torque rope is transferred to the inner cannula. Additional details regarding the shape, size and dimensions of the ferrule are shown in FIGS. **29A-29E**. Depending on the size of the torque rope or flexible cable used in the endoscopic tool **2110**, the shape and size of the ferrule may vary. Further, the ferrules shown

in FIGS. **29A-29E** are merely shown for the sake of example and are not intended to be limited to the particular size, shape, or dimensions shown in the Figures. In some implementations, the ends of the torque rope can be inserted into and bonded to short lengths of hypodermic tubing. Doing so can make it easier to attach the ferrule to the distal end, and to clamp onto on the proximal end (towards the drive shaft). In some implementations, a graphite filled cyanoacrylate, such as loctite black max, can be used. Other similar types of materials can also be used instead.

FIGS. **30A-30C** illustrate aspects of an endoscopic assembly in which the tip is press-fit. In some implementations, the flexible portion of the endoscopic tool can include a balloon structure that can be deployed such that the balloon structure can engage with the inner walls of the endoscope. The balloon structure can be coupled to an air supply line **3006** that is coupled to an air supply source, such that when air is supplied, the balloon can expand and engage with the inner wall of the endoscope. In some implementations, the balloon structure can expand asymmetrically, as shown in FIG. **30A**. In some implementations, the air supply source can be actuated via a foot pedal. An irrigation line **3002** can be configured to supply an irrigation fluid. The irrigation fluid can flow towards the cutting tool, where the irrigation fluid can then flow through the suction channels **3004**. The irrigation fluid can prevent the suction channels from blockages. As shown in FIG. **30C**, the flexible cable or torque rope can be press fit into a button at one end of the cutting tool.

FIGS. **31A-31C** illustrate aspects of an endoscopic assembly in which the tip is press-fit. In some implementations, the flexible portion of the endoscopic tool can include a balloon structure that can be deployed such that the balloon structure can engage with the inner walls of the endoscope. The balloon structure can be coupled to an air supply source such that when air is supplied, the balloon can expand and engage with the inner wall of the endoscope. In some implementations, the balloon structure can expand symmetrically, as shown in FIG. **31A**. An irrigation line can be configured to supply an irrigation fluid. The irrigation fluid can flow towards the cutting tool, where the irrigation fluid can then flow through the suction channels. The irrigation fluid can prevent the suction channels from blockages. As shown in FIG. **31C**, the flexible cable or torque rope can be welded to one end of the cutting tool.

FIG. **32** shows a top view of an example flexible portion of an endoscopic tool. In some implementations, the flexible portion shown in FIG. **32** can be used with the implementations shown in FIGS. **30A-C** and **31A-C**. The flexible portion **3202** includes a center channel **3204** through which the flexible cable passes through. The flexible portion **3202** also includes two aspiration channels **3406a** and **3406b**, an irrigation channel **3408** and an air supply channel **3410**.

In some implementations, the operating speed of the torque rope can vary. In some example implementations, the torque rope can have an operating speed within the range of 0.5k RPM to 20k RPM. In some implementations, the torque rope can have an operating speed within the range of 1k RPM and 4k RPM. In some implementations, the operating speed of the torque rope can vary. In some example implementations, the torque rope can operate with a torque of 5 to 100 mN\*m (milliNewton Meters). In some implementations, the torque rope can operate with a torque of 20 to 50 mN\*m (milliNewton Meters). However, it should be appreciated by those skilled in the art that the torque and running speed of the flexible cable can be altered based on the performance of the endoscopic tool. In some implementations, various factors contribute to the performance of the

endoscopic tool, including the amount of suction, the type of cutter, the size of the opening in the cutter, amongst others. As such, the torque and running speed at which to operate the flexible cable can be dependent on a plurality of factors.

FIG. 33 is a cross-sectional view of an example cutting assembly of an endoscopic tool using a torque rope. The cutting assembly 3300 includes an outer cannula 3302, an inner cannula 3304 including an inner cutter 3306 disposed within the outer cannula 3302, a PTFE bearing 3308, a semi-compliant balloon 3310, and a multilumen extrusion 3312. A torque rope 3314 can be coupled to the inner cutter 3306. The diameter of the outer cannula can be between 0.05 inches to a size suitable to pass through an instrument channel of an endoscope.

FIGS. 34A-34C are cross-sectional views of different configurations of the flexible portion region of one implementation of an endoscopic tool described herein. The flexible portion region can include an aspiration lumen 3402, an inflation lumen 3404, a lavage or irrigation lumen 3406 and a torque rope.

FIG. 35 shows various views of portions of an endoscopic tool. The endoscopic tool can include an outer cannula 1, an inner cutter 2, an inner cannula 3, a torque rope 4, a trilumen extrusion 5, a balloon 6, a PTFE washer 7, two sidearms 8, a proximal plug 9, an PTFE gasket 10 and a gasket cap 11.

FIG. 36 shows a cross-sectional view of the flexible portion region of one implementation of an endoscopic tool described herein. The flexible portion region can include an outer inflation jacket 3602, an outer coil 3604, a torque coil 3606, a multi-lumen extrusion 3608 disposed within the torque coil. The multi-lumen extrusion 3608 can include a lavage lumen 3610 and an aspiration lumen 3612.

FIG. 37 shows a cross-sectional view of one implementation of the endoscopic tool described herein. The endoscopic tool includes an outer cannula 3702, an inner cutter 3704, an inner torque coil 3706, an outer coil 3708, an outer inflation jacket and balloon 3710, and a multi-lumen extrusion 3712. A gear 3714, such as a worm gear can engage with the torque coil to drive the inner cutter.

FIG. 38 shows various views of a distal portion of one implementation of an endoscopic tool described herein. The endoscopic tool includes an outer cutter 3802 that defines an opening 3804. The endoscopic tool also includes an inner cutter 3806 disposed within the outer cutter. The inner cutter is coupled to a torque coil 3808. The torque coil is disposed within a PET heat shrink 3810 or other type of tubing. The outer cutter is coupled to a braided shaft 3812 to allow the outer cutter 3802 to rotate relative to the inner cutter 3806.

FIG. 39 shows cross-sectional views of the distal portion of the endoscopic tool shown in FIG. 38 along the sections B-B and sections C-C.

In some implementations, an endoscopic instrument insertable within a single instrument channel of an endoscope can include a power driven instrument head or cutting assembly that is configured to resect material at a site within a subject. The cutting assembly includes an outer cannula and an inner cannula disposed within the outer cannula. The outer cannula defines an opening through which material to be resected enters the cutting assembly. The endoscopic instrument also includes a flexible outer tubing coupled to the outer cannula and configured to cause the outer cannula to rotate relative to the inner cannula. The flexible outer tubing can have an outer diameter that is smaller than the instrument channel in which the endoscopic instrument is insertable. The endoscopic instrument also includes a flexible torque coil having a portion disposed within the flexible outer tubing. The flexible torque coil having a distal end

coupled to the inner cannula. The flexible torque coil is configured to cause the inner cannula to rotate relative to the outer cannula. The endoscopic instrument also includes a proximal connector coupled to a proximal end of the flexible torque coil and configured to engage with a drive assembly that is configured to cause the proximal connector, the flexible torque coil and the inner cannula to rotate upon actuation. The endoscopic instrument also includes an aspiration channel having an aspiration port configured to engage with a vacuum source. The aspiration channel is partially defined by an inner wall of the flexible torque coil and an inner wall of the inner cannula and extends from an opening defined in the inner cannula to the aspiration port. The endoscopic instrument also includes an irrigation channel having a first portion defined between an outer wall of the flexible torque coil and an inner wall of the flexible outer tubing and configured to carry irrigation fluid to the aspiration channel.

In some implementations, the proximal connector is hollow and an inner wall of the proximal connector defines a portion of the aspiration channel. In some implementations, the proximal connector is a rigid cylindrical structure and is configured to be positioned within a drive receptacle of the drive assembly. The proximal connector can include a coupler configured to engage with the drive assembly and a tensioning spring configured to bias the inner cannula towards a distal end of the outer cannula. In some implementations, the tensioning spring is sized and biased such that the tensioning spring causes a cutting portion of the inner cannula to be positioned adjacent to the opening of the outer cannula. In some implementations, the proximal connector is rotationally and fluidly coupled to the flexible torque coil. In some implementations, the tensioning spring can be sized and biased such that the distal tip of the inner cannula can contact the inner distal wall of the outer cannula. This may limit any lateral or undesired movement generated due to whip at the distal end of the inner cannula caused by the rotation of the flexible torque coil.

In some implementations, the endoscopic instrument also includes a lavage connector including an irrigation entry port and a tubular member coupled to the lavage connector and the flexible outer tubing. An inner wall of the tubular member and the outer wall of the flexible torque coil can define a second portion of the irrigation channel that is fluidly coupled to the first portion of the irrigation channel. In some implementations, the endoscopic instrument also includes a rotational coupler coupling the flexible outer tubing to the tubular member and configured to cause the flexible outer tubing to rotate relative to the tubular member and cause the opening defined in the outer cannula to rotate relative to the inner cannula. In some implementations, the lavage connector defines an inner bore within which the flexible torque coil is disposed.

In some implementations, the endoscopic instrument also includes a lining within which the flexible torque coil is disposed, the outer wall of the lining configured to define a portion of the irrigation channel. In some implementations, the inner cannula is configured to rotate about a longitudinal axis of the inner cannula and relative to the outer cannula and the aspiration channel is configured to provide a suction force at the opening of the inner cannula.

In some implementations, the flexible torque coil includes a plurality of threads. Each of the plurality of threads can be wound in a direction opposite to a direction in which one or more adjacent threads of the plurality of threads is wound. In some implementations, the flexible torque coil includes a plurality of layers. Each of the plurality of layers can be

wound in a direction opposite to a direction in which one or more adjacent layers of the plurality of layers is wound. In some implementations, each layer can include one or more threads. Additional details regarding the flexible torque coil are described above in regard to the discussion of the flexible cable with respect to at least FIGS. 22A-22H.

In some implementations, the flexible outer tubing has a length that exceeds the length of the endoscope in which the endoscopic instrument is insertable. In some implementations, the flexible outer tubing has a length that is at least 100 times larger than an outer diameter of the flexible outer tubing. In some implementations, the flexible portion is at least 40 times as long as the cutting assembly.

FIG. 40 shows a perspective view of an endoscopic tool 4000 and a portion of a drive assembly 4050 configured to drive the endoscopic tool. Referring now also to FIGS. 41, 42 and 43, FIG. 41 shows a top view of the endoscopic tool 4000 and a top exposed view of the portion of the drive assembly 4050 shown in FIG. 40. FIG. 42 shows a cross-sectional view of the endoscopic tool 4000 and the portion of the drive assembly 4050 across the section A-A. FIG. 43 shows an enlarged view of the drive connector of the endoscope and the portion of the drive assembly 4050. FIG. 44 shows a perspective view of the endoscopic tool 4000 and a portion of the drive assembly shown in FIG. 40. FIG. 45 shows a cross-sectional view of the endoscopic tool and the portion of the drive assembly across the section B-B. FIG. 46 shows an enlarged cross-sectional view of the rotational coupler section of the endoscopic tool. FIG. 47A and FIG. 47B show a top view and a cross-sectional view of the rotational coupler of the endoscopic tool.

The endoscopic tool 4000, as shown in FIGS. 40-47B, may be configured to be inserted within an instrument channel of an endoscope. Examples of the endoscope can include a gastroscope, such as a colonoscope, a laryngoscope, or any other flexible endoscope. The endoscopic tool can include a flexible portion 4002 that is shaped, sized and configured to be inserted within the instrument channel, while a remaining portion of the endoscopic tool 4000 can be configured to remain outside the instrument channel of the endoscope. The flexible portion 4002 can be shaped and sized to fit within the instrument channel and be configured to navigate through a tortuous path defined by the instrument channel while the endoscope is inserted within the patient. In the case of colonoscopes, the endoscope can form a series of bends of over at least 60 degrees and in some situations, over 90 degrees.

The endoscopic tool 4000 can include a cutting assembly 4010 configured to resect material at a site within a subject. The cutting assembly 4010 can be similar to the cutting assembly 160 described in FIG. 1C and elsewhere in the description and figures. In some implementations, the cutting assembly 4010 can include an outer cannula and an inner cannula disposed within the outer cannula. The outer cannula can define an opening 4012 through which material to be resected can enter the cutting assembly 4010. In some implementations, the opening 4012 is defined through a portion of the radial wall of the outer cannula. In some implementations, the opening may extend around only a portion of the radius of the outer cannula, for example, up to one third of the circumference of the radial wall. As the aspiration channel 4090 extends between the aspiration port 4092 and the opening 4012, any suction applied at the aspiration port 4092 causes a suction force to be exerted at the opening 4012. The suction force causes material to be introduced into the opening of the outer cannula, which can then be cut by the inner cannula of the cutting assembly.

The inner cannula can include a cutting section that is configured to be positioned adjacent to the opening 4012 such that material to be resected that enters the cutting assembly via the opening 4012 can be resected by the cutting section of the inner cannula. The inner cannula may be hollow and an inner wall of the inner cannula may define a portion of an aspiration channel that may extend through the length of the endoscopic tool. A distal end of the inner cannula can include the cutting section while a proximal end of the inner cannula can be open such that material entering the distal end of the inner cannula via the cutting section can pass through the proximal end of the inner cannula. In some implementations, the distal end of the inner cannula can come into contact with an inner surface of a distal end of the outer cannula. In some implementations, this can allow the inner cannula to rotate relative to the outer cannula along a generally longitudinal axis, providing more stability to the inner cannula while the inner cannula is rotating. In some implementations, the size of the opening can dictate the size of the materials being cut or resected by the inner cannula. As such, the size of the opening may be determined based in part on the size of the aspiration channel defined by the inner circumference of the flexible torque coil.

The endoscopic instrument 4000 can include a flexible torque coil 4080 that is configured to couple to the proximal end of the inner cannula at a distal end of the flexible torque coil 4080. The flexible torque coil can include a fine coil with multiple threads and multiple layers, which can transmit the rotation of one end of the flexible torque coil to an opposite end of the flexible torque coil. Each of the layer of thread of the flexible torque coil can be wound in a direction opposite to a direction in which each of the layer of thread adjacent to the layer of thread is wound. In some implementations, the flexible torque coil can include a first layer of thread wound in a clockwise direction, a second layer of thread wound in a counter-clockwise direction and a third layer of thread wound in a clockwise direction. In some implementations, the first layer of thread is separated from the third layer of thread by the second layer of thread. In some implementations, each of the layers of thread can include one or more threads. In some implementations, the layers of thread can be made from different materials or have different characteristics, such as thickness, length, among others.

The flexibility of the torque coil 4080 allows the coil to maintain performance even in sections of the torque coil 4080 that are bent. Examples of the flexible torque coil 4080 include torque coils made by ASAHI INTECC USA, INC located in Santa Ana, Calif., USA. In some implementations, the flexible torque coil 4080 can be surrounded by a sheath or lining to avoid frictional contact between the outer surface of the flexible torque coil 4080 and other surfaces. In some implementations, the flexible torque coil 4080 can be coated with Polytetrafluoroethylene (PTFE) to reduce frictional contact between the outer surface of the flexible torque coil 4080 and other surfaces. The flexible torque coil 4080 can be sized, shaped or configured to have an outer diameter that is smaller than the diameter of the instrument channel of the endoscope in which the endoscopic tool is to be inserted. For example, in some implementations, the outer diameter of the flexible torque coil can be within the range of 1-4 millimeters. The length of the flexible torque coil can be sized to exceed the length of the endoscope. In some implementations, the inner wall of the flexible torque coil 4080 can be configured to define another portion of the aspiration channel that is fluidly coupled to the portion of the aspiration channel defined by the inner wall of the inner

cannula of the cutting assembly **4010**. A proximal end of the flexible torque coil **4080** can be coupled to a proximal connector assembly **4070**, details of which are provided below.

The endoscopic instrument **4000** can include a flexible outer tubing **4086** that can be coupled to the proximal end of the outer cannula. In some implementations, a distal end of the flexible outer tubing **4086** can be coupled to the proximal end of the outer cannula using a coupling component. In some implementations, the outer cannula can be configured to rotate responsive to rotating the flexible outer tubing. In some implementations, the flexible outer tubing **4086** can be a hollow, braided tubing that has an outer diameter that is smaller than the instrument channel of the endoscope in which the endoscopic instrument **4000** is to be inserted. In some implementations, the length of the flexible outer tubing **4086** can be sized to exceed the length of the endoscope. The flexible outer tubing **4086** can define a bore through which a portion of the flexible outer tubing **4086** extends. The flexible outer tubing **4086** can include braids, threads, or other features that facilitate the rotation of the flexible outer tubing **4086** relative to the flexible torque coil, which is partially disposed within the flexible outer tubing **4086**.

The endoscopic instrument **4000** can include a rotational coupler **4030** configured to be coupled to a proximal end of the flexible outer tubing **4086**. The rotational coupler **4030** may be configured to allow an operator of the endoscopic tool to rotate the flexible outer tubing **4086** via a rotational tab **4032** coupled to or being an integral part of the rotational coupler **4030**. By rotating the rotational tab **4032**, the operator can rotate the flexible outer tubing and the outer cannula along a longitudinal axis of the endoscope and relative to the endoscope and the inner cannula of the cutting assembly **4010**. In some implementations, the operator may want to rotate the outer cannula while the endoscopic instrument is inserted within the endoscope while the endoscope is within the patient. The operator may desire to rotate the outer cannula to position the opening of the outer cannula to a position where the portion of the radial wall of the outer cannula within which the opening is defined may be aligned with the camera of the endoscope such that the operator can view the material entering the endoscopic instrument for resection via the opening. This is possible in part because the opening is defined along a radial wall extending on a side of the outer cannula as opposed to an opening formed on the axial wall of the outer cannula. In some implementations, a proximal end **4034** of the rotational coupler **4030** can be coupled to a lavage connector **4040**. In some implementations, the rotational coupler **4030** can be a rotating luer component that allows a distal end **4036** of the rotational coupler **4030** rotate relative to the proximal end **4034** of the rotational coupler **4030**. In this way, when the flexible outer tubing **4086** is rotated, the component to which the proximal end of the rotational coupler **4030** is coupled, is not caused to rotate. In some implementations, the proximal end **4034** of the rotational coupler **4030** can be coupled to an outer tubular member **4044** configured to couple the proximal end **4034** of the rotational coupler **4030** to the lavage connector **4040**. The rotational coupler **4030** can define a bore along a central portion of the rotational coupler **4030** through which a portion of the flexible torque coil **4080** extends. In some implementations, the rotational coupler **4030** can be a male to male rotating luer connector. In some implementations, the rotational coupler can be configured to handle pressures up to 1200 psi.

The lavage connector **4040** can be configured to introduce irrigation fluid into the endoscopic tool **4000**. The lavage connector **4040** includes a lavage port **4042** configured to engage with an irrigation source, such as a water container. In some implementations, the lavage connector **4040** can be a Y port used in fluid delivery systems that complies with medical device industry standards and is sized to couple to the flexible outer tubing **4086** or the outer tubular member **4044** that serves to couple a distal end **4048** of the lavage connector **4040** to the proximal end **4034** of the rotational coupler **4030**. In some implementations, the lavage connector can define a hollow channel between the proximal end **4046** and the distal end **4048** of the lavage connector **4040** that is sized to allow the flexible torque coil **4080** to pass through the hollow channel defined through the lavage connector **4040**.

As described above, the proximal connector assembly **4070** is configured to be coupled to a proximal end of the flexible torque coil **4080**. The proximal connector assembly **4070** can be configured to engage with the drive assembly **4050** that is configured to provide torque to the inner cannula via the proximal connector assembly **4070** and the flexible torque coil **4080**. The proximal connector assembly **4070** can further define a portion of the aspiration channel and be configured to fluidly couple the aspiration channel to a vacuum source to facilitate the removal of material entering the aspiration channel. In some implementations, a proximal end of the proximal connector assembly **4070** can include an aspiration port **4092** through which the material that enters the endoscopic tool **4000** can be withdrawn from the endoscopic tool **4000**.

In some implementations, the endoscopic tool **4000** can be configured to be driven by the drive assembly **4050**. The drive assembly **4050** is configured to provide rotational energy from an energy source to the endoscopic tool **4000**. The drive assembly **4050** can include a housing **4060** that may house a first beveled gear **4054** and a second beveled gear **4056** that are positioned such that the rotation of the first beveled gear **4054** causes a rotation of the second beveled gear **4056**. The second beveled gear **4056** can be coupled to a drive receptacle that is sized and shaped to receive and engage with the proximal connector assembly **4070** of the endoscopic tool **4000**. In some implementations, the first beveled gear **4054** can be coupled to a motor (not shown) or other rotational source via a rotational input shaft **4052**.

The proximal connector assembly **4070** can include a hollow drive shaft **4072**, a coupler **4076** through which the hollow drive shaft **4072** passes and a tensioning spring **4074** coupled to the hollow drive shaft **4072**. A distal end of the drive shaft **4072** can be coupled to the proximal end of the flexible torque coil **4080**. In some implementations, the drive shaft **4072** and the flexible torque coil **4080** can be permanently coupled to one another. In some implementations, the drive shaft **4072** and flexible torque coil **4080** can be coupled using a coupler, a press fit, a weld, such as a butt weld, or any other attachment means that allows the flexible torque coil **4080** to rotate when the drive shaft **4072** rotates and to allow material passing through the flexible torque coil **4080** to flow through the drive shaft **4072**. A proximal end of the drive shaft **4072** can define the aspiration port **4092**. In some implementations, the aspiration port **4092** can be configured to engage with a vacuum source causing material entering the opening **4012** to flow through the aspiration channel **4090** and out of the endoscopic tool through the aspiration port **4092**.

A coupler **4076**, such as a hex-shaped coupler, can be configured to couple with the hollow drive shaft. In some implementations, the hex-shaped coupler is a part of the hollow drive shaft. The coupler **4076** can include an outer wall that is configured to engage with an inner wall of a drive receptacle **4058**. The drive receptacle **4058** is coupled to the second beveled gear **4056** and is configured to rotate when the second beveled gear **4056** rotates. In some implementations, the drive receptacle **4058** can be a hollow cylindrical tube. In some implementations, a proximal end **4059** of the drive receptacle **4058** can include an opening defined by an inner wall of the proximal end of the drive receptacle **4058** that has a diameter that smaller than the inner diameter of the remaining portion of the drive receptacle **4058**. In some implementations, the diameter of the opening through the proximal end **4059** of the drive receptacle **4058** can be large enough to receive the drift shaft **4072** but small enough to prevent the tensioning spring **4074** coupled to the drive shaft **4072** from passing through the opening. In some implementations, the inner diameter of the remaining portion of the drive receptacle is sized to engage with the coupler **4076**.

The tensioning spring **4074** can be biased in such a way that, during operation of the endoscopic tool **4000**, the tensioning spring **4074** may prevent the drive shaft **4072**, the flexible torque coil **4080** and the inner cannula from sliding towards the proximal end of the endoscopic tool **4000**. In some implementations, without the tensioning spring **4074**, the inner cannula may slide away from the distal end of the endoscopic tool **4000**. This may be due to a force applied by the material to be resected at the opening **4012**. In some implementations, the tensioning spring **4074** provides a countering force that prevents the inner cannula from sliding away from the distal end when the inner cannula comes into contact with the material to be resected at the opening **4012**. In some implementations, the tensioning spring **4074** can be configured to bias the distal end of the inner cannula to contact an inner wall of the distal end of the outer cannula. In some implementations, the tensioning spring **4074** can be sized and biased such that the distal tip of the inner cannula can contact the inner distal wall of the outer cannula. This may limit any lateral or undesired movement generated due to whip at the distal end of the inner cannula caused by the rotation of the flexible torque coil.

The housing **4060** can be configured to engage with an aspiration end cap **4062** and a locking collar **4064**. In some implementations, the aspiration end cap **4062** can be configured to allow a vacuum source to maintain a secure connection with the aspiration port **4092** of the drive shaft **4072**. In some implementations, the aspiration end cap **4062** can be configured to allow the drive shaft **4072** to rotate while maintaining a secure connection between the vacuum source and the aspiration port **4092** of the drive shaft **4072**. In some implementations, the aspiration end cap **4062** can be configured to be secured to a portion of the housing **4060** in such a way that the aspiration port of the drive shaft **4072** is accessible via an opening of the aspiration end cap **4062**. In some implementations, the vacuum source can be coupled to the end cap **4062** such that the vacuum source does not rotate along with the proximal end of the drive shaft **4072**. In some implementations, one or more bearings or bushings can be used to allow facilitate a fluid connection between the aspiration port **4092** of the drive shaft **4072** and the vacuum source without causing the vacuum source to rotate with the drive shaft **4072**.

The locking collar **4064** can be configured to secure the lavage connector **4040** to the proximal connector assembly **4070**. In some implementations, the locking collar **4064** can

be configured to secure a proximal end **4046** of the lavage connector **4040** to the housing **4060** of the drive assembly **4050**. The locking collar **4064** can further be configured to prevent the proximal connector assembly **4070** from disengaging with the drive receptacle **4058** and moving towards the distal end of the endoscopic tool **4000**. In some implementations, the locking collar **4064** can be configured to secure a lining **4082** within which the flexible torque coil **4080** is disposed to the flexible torque coil **4080**, the drive shaft **4072** or the housing **4060**. In some implementations, the lining **4082** can serve as a heat shrink to reduce the dissipation of heat generated in the flexible torque coil to other components of the endoscopic tool. In some implementations, the outer wall of the lining **4082** can define a portion of the irrigation channel, while the inner wall of the lining **4082** can serve to prevent any material passing through the aspiration channel from escaping through the walls of the flexible torque coil. In some implementations, the lining **4082** can also prevent the irrigation fluid passing through the irrigation channel to flow into the aspiration channel **4090** through the walls of the flexible torque coil **4080**.

The distal end **4048** of the lavage connector **4040** can be configured to engage with an inner wall of the outer tubing **4044**. In some implementations, the distal end **4048** of the lavage connector **4040** can be press fit into a proximal end of the outer tubing **4044**. In some implementations, a connector connecting the distal end **4048** of the lavage connector **4040** and the outer tubing can be used. The inner wall of the outer tubing **4044** and the outer wall of the lining **4082** can define a portion of the irrigation channel **4096**. The outer tubing **4044** can extend from the distal end **4048** of the lavage connector **4040** to a proximal end **4034** of the rotational coupler **4030**. The distal end of the outer tubing **4044** can be configured to engage with the proximal end **4034** of the rotational coupler **4030**.

In some implementations, the irrigation channel can extend from the irrigation entry port to the opening of the outer cannula. The irrigation channel can be defined by the inner wall of the outer tubular member, the rotational coupler, the inner wall of the outer tubing and the inner wall of outer cannula. In some implementations, the irrigation channel can also be defined by the outer wall of the inner cannula and the outer wall of the flexible torque coil **4080**. In some implementations, the endoscopic instrument **4000** can also include the hollow lining **4082** that is sized to fit around the flexible torque coil **4080**. In some implementations, the hollow lining **4082** can serve as a barrier between the irrigation channel **4096** and the aspiration channel **4090**. In some implementations, the hollow lining **4082** can prevent air or other fluids to seep through the threads of the flexible torque coil **4080**. In addition, the hollow lining can allow the aspiration channel to maintain a suction force throughout the length of the aspiration channel by preventing air to escape or enter through the threads of the flexible torque coil **4080**.

As described above, the cutting assembly **4010** includes the outer cannula. The braided tubing **4086** is coupled to the outer cannula such that rotating the rotational tab **4032** of the rotational coupler **4030** results in rotating the outer cannula. The outer cannula includes the opening **4012** at a distal end of the outer cannula. The opening is defined within a portion of the radial wall of the outer cannula and may only extend around a portion of the radius of the outer cannula. As the aspiration channel **4090** extends between the aspiration port **4092** and the opening **4012**, any suction applied at the aspiration port **4092** causes a suction force to be exerted at



the opening **4012**. The suction force causes material to be introduced into the opening of the outer cannula, which can then be cut by the inner cannula of the cutting assembly. In some implementations, the aspirated material can be collected in a collection cartridge. In some implementations, the collection cartridge can be fluidly coupled to the proximal end of the aspiration channel.

The inner cannula is disposed within the outer cannula and configured to resect any material that is sucked into or otherwise enters the opening **4012** due to the suction force in the aspiration channel **4090**. The inner cannula can cut, resect, excise, debride or shave the material at the opening **4012** based in part on the interaction between the cutting surface and the wall of the outer cannula that defines the opening. In some implementations, the rotational movement of the cutting surface relative to the opening **4012** can cause the material to be cut, resected, excised, or shaved. The flexible torque coil is coupled to the inner cannula and causes the inner cannula to rotate along the longitudinal axis of the inner cannula. As the outer cannula is coupled to the outer tubing and is not rotationally coupled to the inner cannula or flexible torque coil, the inner cannula rotates relative to the outer cannula. A gap between an outer wall of the inner cannula and the inner wall of the outer cannula defines a portion of the irrigation channel through which irrigation fluid can flow from the lavage connector **4040** through the irrigation channel portion defined in part by the outer tubing **4044**, the rotational coupler **4030**, and the flexible outer tubing **4086** towards the cutting surface of the inner cannula. The inner cannula may define a portion of the aspiration channel through which excised or resected material and the irrigation fluid can flow from the cutting surface of the inner cannula towards the aspiration port **4092**.

The length of the cutting assembly **4010** may be sized to allow the endoscopic instrument **4000** to traverse through the length of the endoscope while the endoscope is inserted inside a patient. In some implementations, the endoscope may be disposed within the patient and the endoscope may include bends that exceed 60 degrees. As such, the length of the cutting assembly **4010** may not exceed a few centimeters. In some implementations, the length of the cutting assembly **4010** may be less than 1% of the length of the endoscopic tool **4000**, or the length of the flexible portion of the endoscope within which the endoscopic tool can be inserted. As described above, tissue sensing capabilities can be implemented with the cutting assembly serving as a portion of the tissue sensor.

It should be appreciated that one or more seals, bearings, and other components may be used. Seals may be used to maintain pressure, prevent fluid leaks, or to securely engage components to one another. In some implementations, bearings may be used to allow components to rotate relative to one another without adversely affecting the components or the performance of the endoscopic tool.

FIG. **45** shows a cross-sectional view of the endoscopic tool and the portion of the drive assembly across the section B-B. As shown in FIG. **45**, the second beveled gear **4056** may be configured to engage with the drive receptacle **4058** of the drive assembly **4050**. The proximal connector **4070** of the endoscopic tool **4000**, which includes the coupler **4076** and the drive shaft **4072**, can be inserted disposed within the drive receptacle **4058**. The outer wall of the coupler **4076** is sized to engage with the inner wall of the drive receptacle **4058** such that when the drive receptacle **4058** rotates, the coupler **4076** also rotates. Because the coupler **4076** is coupled to the drive shaft **4072**, the drive shaft **4072** may

also rotate when the drive receptacle **4058** rotates. The inner wall of the drive shaft defines a portion of the aspiration channel **4090**.

FIG. **46** shows an enlarged cross-sectional view of the rotational coupler section of the endoscopic tool. FIG. **47A** and FIG. **47B** show a top view and a cross-sectional view of the rotational coupler of the endoscopic tool.

As shown in FIGS. **46-47B**, the outer tubing **4044** is configured to engage with the rotational coupler **4030**. The outer tubing **4044** surrounds the lining **4082**, which in turn surrounds the flexible torque coil **4080**. The inner wall of the flexible torque coil **4080** may define a portion of the aspiration channel **4090**. The space between the inner wall of the outer tubing **4044** and the outer wall or surface of the lining **4082** defines a portion of the irrigation channel. The tab **4032** can be configured to be rotated by an operator of the endoscopic tool. In some implementations, the operator can rotate the tab **4032** while the endoscopic tool is inserted within the instrument channel of the endoscope and cause the outer cannula to rotate relative to the inner cannula and the endoscope. In this way, the operator can position the opening defined through the outer cannula by rotating the outer cannula to a desired position. In some implementations, by providing a mechanism through which the outer cannula can be rotated relative to the endoscope, an operator does not have to be concerned about the position of the opening when the endoscopic tool is inserted within the instrument channel of the endoscope as the operator may be able to adjust the position of the opening by causing the outer cannula to rotate while the endoscopic tool is inserted within the endoscope.

FIG. **48** is a perspective view of a portion of the endoscopic tool inserted for operation within a drive assembly. The drive assembly **4800** includes a drive interface **4810** configured to receive the proximal connector **4070** of the endoscopic tool **4000**. The proximal connector **4070** can engage with the drive receptacle of the drive interface **4810** to translate rotational energy generated by the drive assembly **4800** to the cutting assembly of the endoscopic tool **4000**. The drive assembly **4800** may include a pump **4820** or other fluid displacement device to control the flow of irrigation fluid into the lavage port **4042** of the endoscopic tool **4000**. In some implementations, the pump **4820** can be a peristaltic pump. In some implementations, the pump can be any positive displacement fluid pump. In some implementations, a valve between the pump **4820** and the lavage port **4042** can be placed to control an amount of irrigation fluid entering the endoscopic tool. In some implementations, the speed at which the pump **4820** operates can dictate the rate at which irrigation fluid enters the endoscopic tool. The drive assembly can also include a pinch valve **4830**. In some implementations, the pinch valve can be configured to control the application of a suction force applied to the aspiration channel.

In some implementations, an actuator, such as a control switch can be used to actuate the drive assembly **4800**. In some implementations, the actuator can be a foot pedal, a hand switch, or any other actuation means for controlling the drive assembly **4800**. In some implementations, the actuator can be coupled to the drive means, such as the pump **4820** such that when the actuator is actuated, the pump **4820** begins to rotate, generating torque, which is translated to the proximal connector of the endoscopic tool via the drive interface **4810**. The torque applied to the proximal connector can be translated via the flexible torque coil to the inner cannula, thereby causing the inner cannula to rotate relative to the outer cannula. In some implementations, the actuator

can be coupled to a pinch valve, such as the pinch valve **4830** to control the amount of suction applied to the aspiration channel. In some implementations, the actuator can be configured to actuate both the drive means and the pinch valve simultaneously, such that the inner cannula is rotating while suction is applied through the aspiration channel. In some implementations, the actuator can also be coupled to an irrigation control switch or valve that controls the flow of irrigation fluid into the endoscopic tool via the irrigation entry port **4042**. In some implementations, the actuator can be configured to actuate the drive means, the pinch valve for aspiration and the irrigation control switch for irrigation simultaneously, such that the inner cannula is rotating while suction is applied through the aspiration channel and irrigation fluid is supplied to the endoscopic tool.

In some implementations, a separate irrigation control switch can be configured to control the flow of irrigation fluid through the irrigation channel of the endoscopic tool. An operator can control the volume of irrigation fluid provided to the irrigation channel via the irrigation control switch.

The drive assembly configuration shown in FIGS. **40-48** is one example configuration of a drive assembly. It should be appreciated that the endoscopic tool **4000** can be configured to be driven by other drive assembly configurations. In some implementations, the proximal connector portion of the endoscopic tool **4000** can be modified to engage with other drive assembly configurations. In some implementations, the endoscopic tool **400** can be configured to be packaged as one or more different components that can be assembled prior to inserting the endoscopic tool within the instrument channel of the endoscope. In some implementations, the proximal connector of the endoscopic tool **4000** can be assembled together by an operator of the endoscopic tool after one or more components of the endoscopic tool are caused to engage with components of the drive assembly.

FIG. **49** illustrates another implementation of the endoscopic tool and a drive assembly configured to drive the endoscopic tool. FIG. **50A** is a side view of the endoscopic tool and drive assembly shown in FIG. **49**. FIG. **50B** is a cross-sectional view of the endoscopic tool and drive assembly shown in FIG. **49** taken along the section A-A. The endoscopic tool **4910** is similar to the endoscopic tool **4000** but differs from the endoscopic tool **4000** in that the endoscopic tool **4910** has a different proximal connector **4912**. In this implementation, the proximal connector **4912** can be coupled to a flexible torque coil, similar to the flexible torque coil of the flexible torque coil **4000** shown in FIGS. **40-43**, and include a proximal connector engagement structure **4914** that is configured to engage with a drive assembly **4950**. The proximal connector engagement structure can be sized to engage with the drive assembly **4950** and include one or more engagement surfaces configured to engage with the drive assembly **4950**. The engagement surfaces can be coupled to the drive shaft included within the proximal connector **4912** such that when the drive assembly **4950** applies a rotating force to the engagement surfaces, the drive shaft rotates, which in turn causes the flexible torque coil and cutting assembly of the endoscopic tool **4900** to rotate. In some implementations, the engagement surfaces **4914** can be cylindrical objects having an outer wall configured to engage with the drive assembly **4950** and an inner wall configured to engage with an outer wall of the drive shaft. In some implementations, the proximal connector **4910** can also include a fin **4916** or other structure that prevents the proximal connector **4910** and endoscopic tool **4910** from rotating relative to the drive assembly **4950**. In some imple-

mentations, a side of the fin **4916** can rest on or engage with a mounting structure **4936a** and **4936b**. In this way, when a rotating force is applied by the drive assembly on the engagement surfaces, the fin **4916** prevents the proximal connector **4910** from rotating relative to the drive assembly **4950**. The mounting structures **4936** can be configured such that various components of the drive assembly **4950** can be mounted on or receive support from the mounting structures **4936**.

The drive assembly **4950** can include a retractable arm **4922**, one or more spring loaded bearings **4924**, a drive belt **4932** and a drive wheel **4936** and one or more stationary bearings **4940**. The retractable arm **4922** can be configured to rotate between a first position and a second position. The spring loaded bearings **4924** can be mounted to the retractable arm **4922** and positioned such that when the retractable arm **4922** is in the first position as shown in FIGS. **49** and **50A-B**, the spring loaded bearings **4924** can apply a force on the proximal connector **4912** causing the proximal connector to remain in place while the drive assembly **4950** is actuated. The spring loaded bearings **4924** can be positioned such that when the proximal connector **4912** of the endoscopic tool **4910** is engaged with the drive assembly **4950**, the spring loaded bearings **4924** engage with an engagement component **4916** of a drive shaft (not shown) disposed within the proximal connector **4912**. The engagement component **4916** can be strategically located on the proximal connector **4912** such that when the retractable arm **4922** is in the first position, the spring loaded bearings **4924** come into contact with the engagement component **4916**. The engagement component **4916** can be cylindrical in shape and surround the drive shaft disposed within the proximal connector **4912**. The engagement component **4916** can form a portion of the outer wall of the proximal connector **4912**. In some implementations, the engagement component **4916** can rotate along a longitudinal axis of the proximal connector **4912** and rotate relative to the proximal connector **4912**. In some implementations, the drive wheel **4936** can be an elastomeric friction drive wheel.

A drive means, such as a motor or other driving source, can drive the drive wheel **4936** mounted on a mounting shaft **4930** via the drive belt **4934** that moves when the drive means is actuated. The drive belt **4934** can cause the drive wheel **4936** to rotate. The engagement component **4916** of the proximal connector **4912** can be configured to contact the drive wheel **4936** when the endoscopic tool is positioned within the drive assembly **4950**. A stationary bearing **4940** of the drive assembly **4950** can be positioned to hold the proximal connector **4912** in place while the rotation of the drive wheel **4936** causes the engagement component **4916** to rotate. The stationary bearing **4940** can also provide a force causing the drive wheel **4936** and the engagement component **4916** to maintain contact.

As shown in FIG. **50B**, when the retractable arm is in the first position, or engaged position, the spring loaded bearings **4924** are in contact with the one or more engagement components **4916** at a first side and the drive wheel **4936** is in contact with the engagement components **4916** at a second side. The spring loaded bearings may allow the engagement components **4916** to rotate when the drive wheel is rotating. The fin **4914** rests against the mounting structures of the drive assembly preventing the endoscopic tool from rotating. When the retractable arm is in a second position, or disengaged position, the spring loaded bearings **4924** are not in contact with the one or more engagement components **4916**. As such, the endoscopic tool is not securely positioned within the drive assembly, and as such,

actuating the drive means may not cause the flexible torque coil within the endoscopic tool to rotate.

It should be appreciated that the outer diameter of the endoscopic instrument may be sized to be inserted within the instrument channel of an endoscope while the endoscope is inserted within a patient. In addition, the endoscopic instrument may be sized to be large enough that the endoscopic tool comes into contact with the inner walls of the instrument channel at various portions of the instrument channel to maintain stability of the endoscopic instrument. If the outer diameter of the endoscopic instrument is much smaller than the inner diameter of the instrument channel, there may be a large amount of space between the endoscopic instrument and the inner wall of the instrument channel, which may allow the endoscopic instrument to move, vibrate or otherwise experience some instability during operation.

It should be appreciated that the Figures shown herein are intended to be for illustrative purposes only and are not intended to limit the scope of the application in any way. In addition, it should be appreciated that the dimensions provided herein are only example dimensions and can vary based on specific requirements. For example, the dimensions may change to alter the aspiration rate, irrigation flow, amount of torque being provided, cutting speed, cutting efficiency, amongst others. Moreover, it should be appreciated that details within the drawings are part of the disclosure. Moreover, it should be appreciated that the shape, materials, sizes, configurations and other details are merely illustrated for the sake of examples and persons having ordinary skill in the art should appreciate that design choices can alter any of the shape, materials, sizes and configurations disclosed herein. For the purpose of this disclosure, the term "coupled" means the joining of two members directly or indirectly to one another. Such joining may be stationary or moveable in nature. Such joining may be achieved with the two members or the two members and any additional intermediate members being integrally formed as a single unitary body with one another or with the two members or the two members and any additional intermediate members being attached to one another. Such joining may be permanent in nature or may be removable or releasable in nature.

What is claimed is:

1. A method of retrieving polyps from a colon of a patient, comprising:

inserting a flexible endoscope within an opening to a colon of a patient;

disposing an endoscopic instrument within an instrument channel of the flexible endoscope to remove at least one polyp from within the colon, the endoscopic instrument including a cutting assembly having an outer cannula, an inner cannula disposed within an outer cannula, and an opening defined along a portion of a radial wall of the outer cannula, the inner cannula rotatably coupled to a flexible torque component having a length that extends along a length of the flexible endoscope, the flexible torque component, upon actuation, providing torque to the inner cannula;

providing irrigation fluid from a lavage port of the endoscopic instrument that remains outside the flexible endoscope while the endoscopic instrument is disposed within the instrument channel, the lavage port fluidly coupled to the outer cannula through an outer tubular member having a proximal end connected to the lavage port and a distal end connected to a proximal end of a rotational coupler, the rotational coupler coupling the outer tubular member to a proximal end of an outer tubing connected to the outer cannula, the rotational

coupler allowing the outer tubing and the outer cannula to rotate relative to the lavage port and the outer tubular member upon rotating a portion of the rotational coupler, the flexible torque component extending through the outer tubular member, the rotational coupler, and the outer tubing;

rotating, via rotation of the portion of the rotational coupler, the outer cannula to a position in which the opening of the outer cannula is viewable via a camera of the flexible endoscope;

positioning the opening at the polyp of the colon; actuating the flexible torque component to rotate the inner cannula relative to the outer cannula, the inner cannula cutting a portion of the polyp as the inner cannula rotates adjacent to the opening; and

actuating a sample retrieval component of the endoscopic instrument to remove the cut portion of the polyp from within the colon via an aspiration channel defined by an inner wall of the inner cannula and the flexible torque component.

2. The method of claim 1, wherein disposing the endoscopic instrument within the instrument channel of the flexible endoscope includes inserting a distal end of the endoscopic instrument in the instrument channel of the flexible endoscope.

3. The method of claim 1, further comprising engaging a proximal connector that is coupled to the flexible torque component and positioned at a proximal end of the endoscopic instrument with a drive assembly configured to provide torque to the flexible torque component.

4. The method of claim 1, further comprising fluidly coupling the sample retrieval component to a distal end of the endoscopic instrument to remove, from the endoscopic instrument, portions of the polyp entering the endoscopic instrument via the opening of the outer cannula.

5. The method of claim 1, wherein the flexible torque component includes a flexible torque coil having a plurality of layers of one or more threads, each of the plurality of layers is wound in a direction opposite to a direction in which one or more adjacent layers of the plurality of layers is wound and the aspiration channel is partially defined by an inner wall of the flexible torque coil.

6. The method of claim 1, wherein actuating the flexible torque component and actuating a sample retrieval component of the endoscopic instrument includes actuating the flexible torque component and actuating the sample retrieval component of the endoscopic instrument simultaneously.

7. The method of claim 1, wherein actuating the flexible torque component includes providing torque to the inner cannula that is sufficient to cut at least a portion of the polyp.

8. The method of claim 1, wherein actuating the flexible torque component includes actuating the flexible torque component to cause an inner cannula of the cutting assembly to rotate relative to the outer cannula via a foot pedal.

9. The method of claim 1, wherein the polyp is a first polyp and further comprising:

upon cutting at least a portion of the first polyp and without removing the endoscopic instrument from the flexible endoscope, positioning the opening of the outer cannula at a second polyp within the colon;

actuating the flexible torque component to rotate the inner cannula relative to the outer cannula, the inner cannula cutting at least a portion of the second polyp; and

actuating the sample retrieval component of the endoscopic instrument to remove the cut portion of the second polyp from within the colon.

10. A method of removing polyps from within a patient, comprising:

inserting a flexible endoscope within an opening of a patient;

disposing an endoscopic instrument within an instrument channel of the flexible endoscope to remove a polyp from the surgical site, the endoscopic instrument including a cutting assembly having an outer cannula, an inner cannula disposed within an outer cannula, and an opening defined along a portion of a radial wall of the outer cannula, the inner cannula rotatably coupled to a flexible torque component having a length that extends along a length of the flexible endoscope, the flexible torque component, upon actuation, providing torque to the inner cannula;

positioning the opening of the outer cannula at the polyp; actuating the flexible torque component to rotate the inner cannula relative to the outer cannula, the inner cannula cutting a portion of the polyp as the inner cannula rotates adjacent to the opening;

providing irrigation fluid from a lavage port of the endoscopic instrument that remains outside the flexible endoscope while the endoscopic instrument is disposed within the instrument channel, the lavage port fluidly coupled to the outer cannula through an outer tubular member having a proximal end connected to the lavage port and a distal end connected to a proximal end of a rotational coupler, the rotational coupler coupling the outer tubular member to a proximal end of an outer tubing connected to the outer cannula, the rotational coupler allowing the outer tubing and the outer cannula to rotate relative to the lavage port and the outer tubular member upon rotating a portion of the rotational coupler, the flexible torque component extending through the outer tubular member, the rotational coupler, and the outer tubing; and

actuating a sample retrieval component of the endoscopic instrument to remove the cut portion of the polyp from within the patient via an aspiration channel defined by an inner wall of the inner cannula and the flexible torque component.

11. The method of claim 10, further comprising rotating, via rotation of the portion of the rotational coupler, the outer cannula to a position in which the opening of the outer cannula is viewable via a camera of the flexible endoscope.

12. The method of claim 10, wherein disposing the endoscopic instrument within the instrument channel of the

flexible endoscope includes inserting a distal end of the endoscopic instrument in the instrument channel of the flexible endoscope.

13. The method of claim 10, further comprising engaging a proximal connector that is coupled to the flexible torque component and positioned at a proximal end of the endoscopic instrument with a drive assembly configured to provide torque to the flexible torque component.

14. The method of claim 10, further comprising fluidly coupling the sample retrieval component to a distal end of the endoscopic instrument to remove, from the endoscopic instrument, cut portions of the polyp entering the endoscopic instrument via the opening of the outer cannula.

15. The method of claim 10, wherein the flexible torque component includes a flexible torque coil having a plurality of layers of one or more threads, each of the plurality of layers is wound in a direction opposite to a direction in which one or more adjacent layers of the plurality of layers is wound and the aspiration channel is partially defined by an inner wall of the flexible torque coil.

16. The method of claim 10, wherein actuating the flexible torque component and actuating a sample retrieval component of the endoscopic instrument includes actuating the flexible torque component and actuating the sample retrieval component of the endoscopic instrument simultaneously.

17. The method of claim 10, wherein actuating the flexible torque component includes providing torque to the inner cannula that is sufficient to cut at least a portion of the polyp.

18. The method of claim 10, wherein actuating the flexible torque component includes actuating the flexible torque component to cause an inner cannula of the cutting assembly to rotate relative to the outer cannula via a foot pedal.

19. The method of claim 10, wherein the polyp is a first polyp and further comprising:

upon cutting at least a portion of the first polyp and without removing the endoscopic instrument from the flexible endoscope, positioning the opening of the outer cannula at a second polyp at another surgical site;

actuating the flexible torque component to rotate the inner cannula relative to the outer cannula, the inner cannula cutting at least a portion of the second polyp; and

actuating the sample retrieval component of the endoscopic instrument to remove the cut portion of the second polyp from within the patient.

\* \* \* \* \*