



US011346690B2

(12) **United States Patent**
Cardenas et al.

(10) **Patent No.:** **US 11,346,690 B2**
(45) **Date of Patent:** **May 31, 2022**

(54) **DEVICE WITH WATER-ACTIVATED, AUTOMATIC DISCONNECT**

21/02 (2013.01); *G06F 8/61* (2013.01); *B63B 2022/006* (2013.01); *B63C 7/26* (2013.01)

(71) Applicant: **Boston Engineering Corporation**,
Waltham, MA (US)

(58) **Field of Classification Search**
CPC *G01D 11/245*; *G01D 21/02*; *B63B 22/003*;
B63B 22/08; *B63B 2022/006*; *G06F 8/61*;
B63C 7/26; *G01N 33/1886*; *G01N 2201/0218*

(72) Inventors: **Robert Lee Cardenas**, Framingham,
MA (US); **Michael Conry**, Beverly,
MA (US); **Michael Rufo**, Hanover, MA
(US)

See application file for complete search history.

(73) Assignee: **Boston Engineering Corporation**,
Waltham, MA (US)

(56) **References Cited**

(*) Notice: Subject to any disclaimer, the term of this
patent is extended or adjusted under 35
U.S.C. 154(b) by 92 days.

U.S. PATENT DOCUMENTS

(21) Appl. No.: **16/854,533**

3,906,565 A 9/1975 Dorrance et al.
3,910,457 A * 10/1975 Sutliff B64D 17/38
222/5
5,209,112 A * 5/1993 McCoy B63B 22/003
73/170.01

(22) Filed: **Apr. 21, 2020**

6,772,705 B2 8/2004 Leonard et al.
6,807,856 B1 10/2004 Webb
(Continued)

(65) **Prior Publication Data**

FOREIGN PATENT DOCUMENTS

US 2021/0214049 A1 Jul. 15, 2021

RU 2609849 2/2017
WO 2012013962 2/2012
WO 2018067738 4/2018

Related U.S. Application Data

Primary Examiner — Anthony D Wiest
(74) *Attorney, Agent, or Firm* — BainwoodHuang

(60) Provisional application No. 62/959,513, filed on Jan.
10, 2020.

(57) **ABSTRACT**

(51) **Int. Cl.**
G01D 11/24 (2006.01)
B63B 22/00 (2006.01)
B63B 22/08 (2006.01)
G01D 21/02 (2006.01)
G06F 8/61 (2018.01)
B63C 7/26 (2006.01)

A technique for managing an attachment between first and second portions of a device. The technique includes a retaining component having a first state in which the retaining component maintains the attachment between the first and second portions by virtue of a rigid characteristic and a second state in which the retaining component loses the rigid characteristic and no longer maintains the attachment. The retaining component transitions from the first state to the second state upon exposure to liquid water.

(52) **U.S. Cl.**
CPC *G01D 11/245* (2013.01); *B63B 22/003*
(2013.01); *B63B 22/08* (2013.01); *G01D*

19 Claims, 9 Drawing Sheets

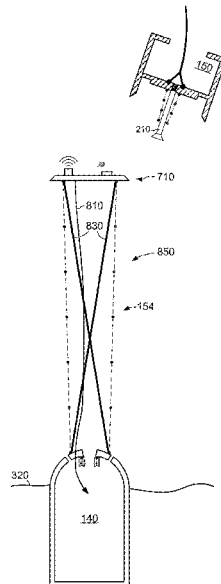

(56)

References Cited

U.S. PATENT DOCUMENTS

8,397,658	B1	3/2013	Imlach et al.
9,709,396	B2 *	7/2017	Chedrawy B63B 22/003
10,638,742	B1 *	5/2020	Barnett A01K 97/125
10,994,818	B2 *	5/2021	Hernandez B63C 9/24
2014/0047682	A1	2/2014	Blackman et al.
2018/0162501	A1	6/2018	Peterson et al.

* cited by examiner

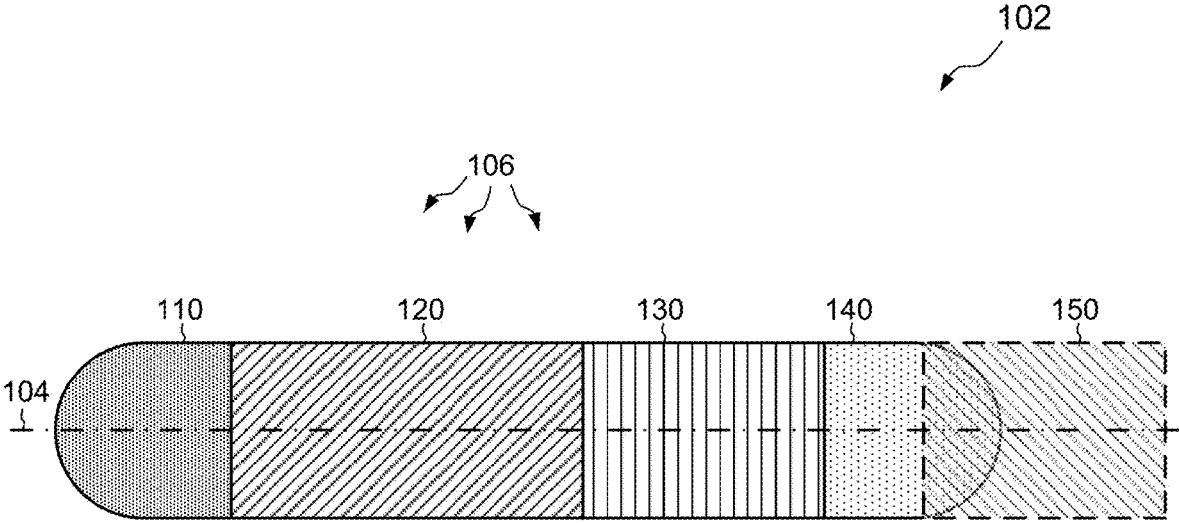

FIG. 1

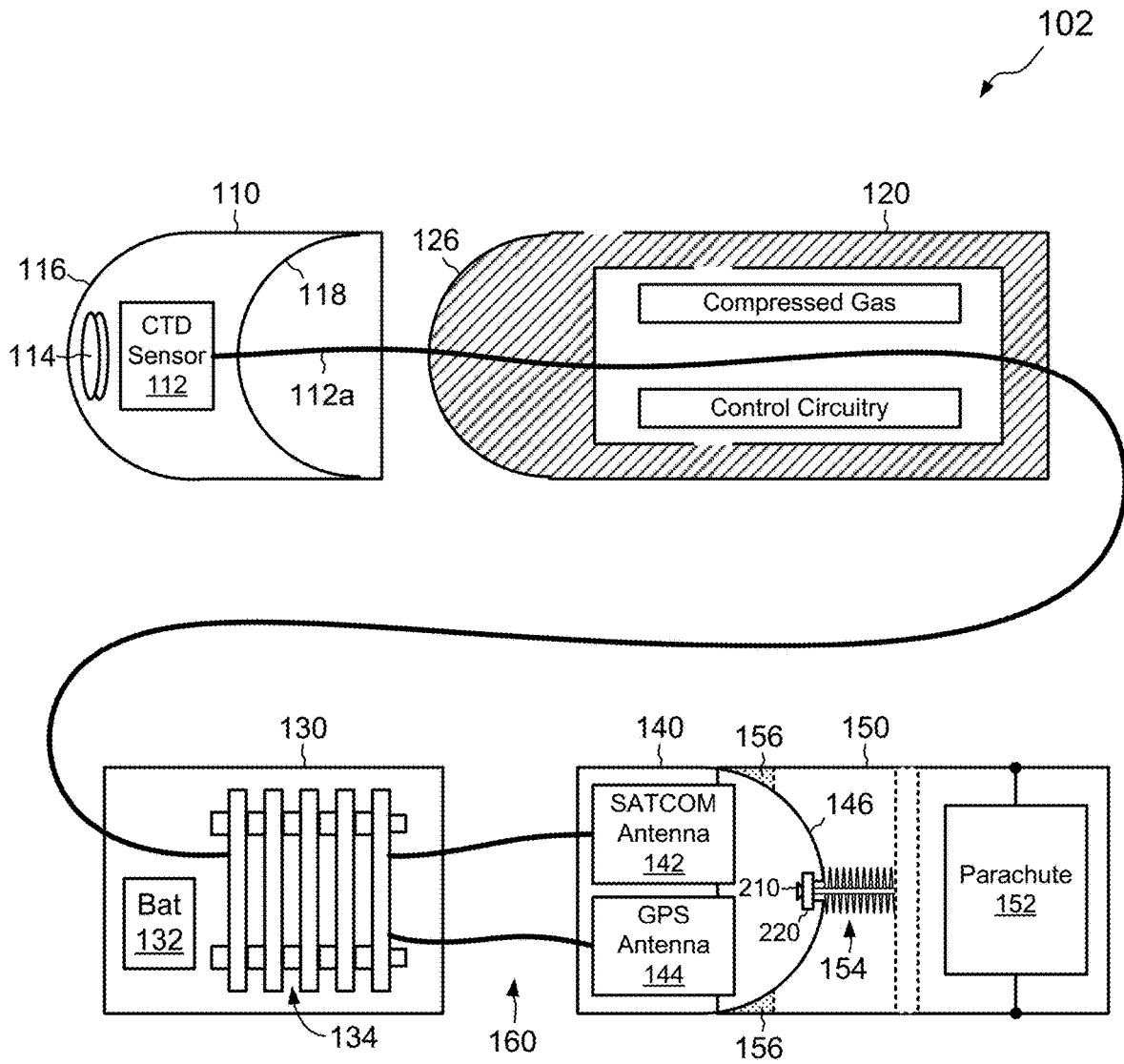

FIG. 2

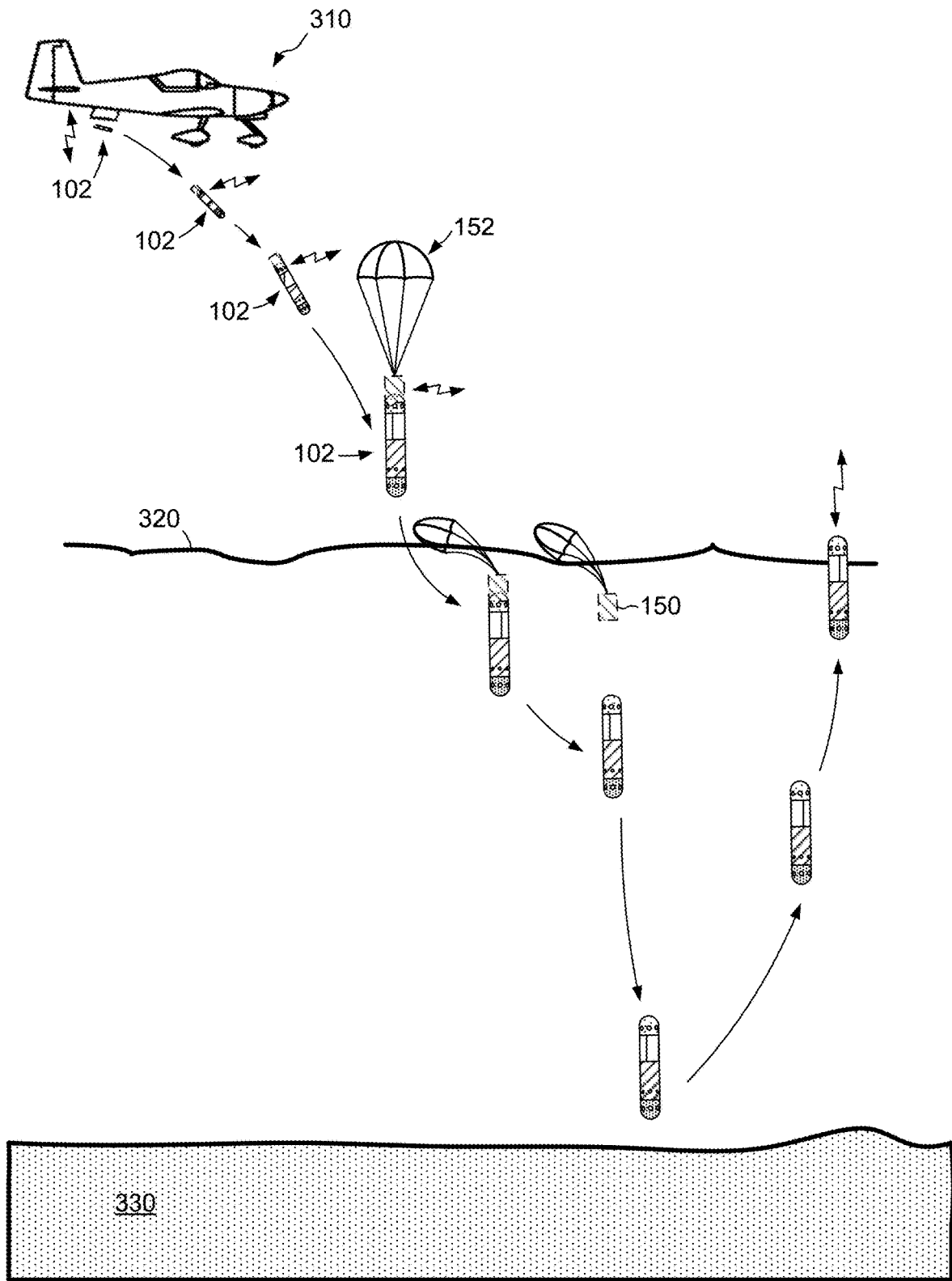

FIG. 3

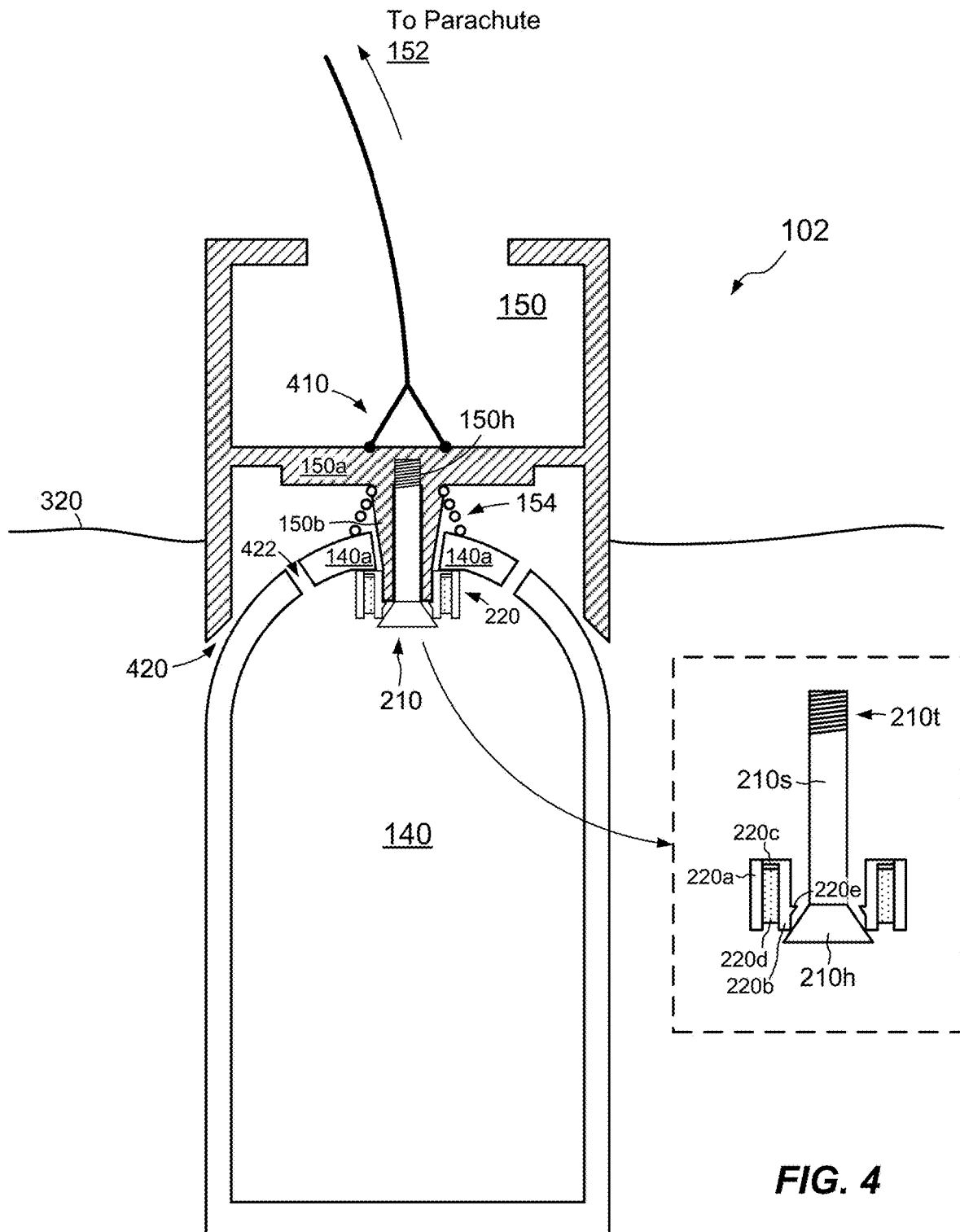

FIG. 4

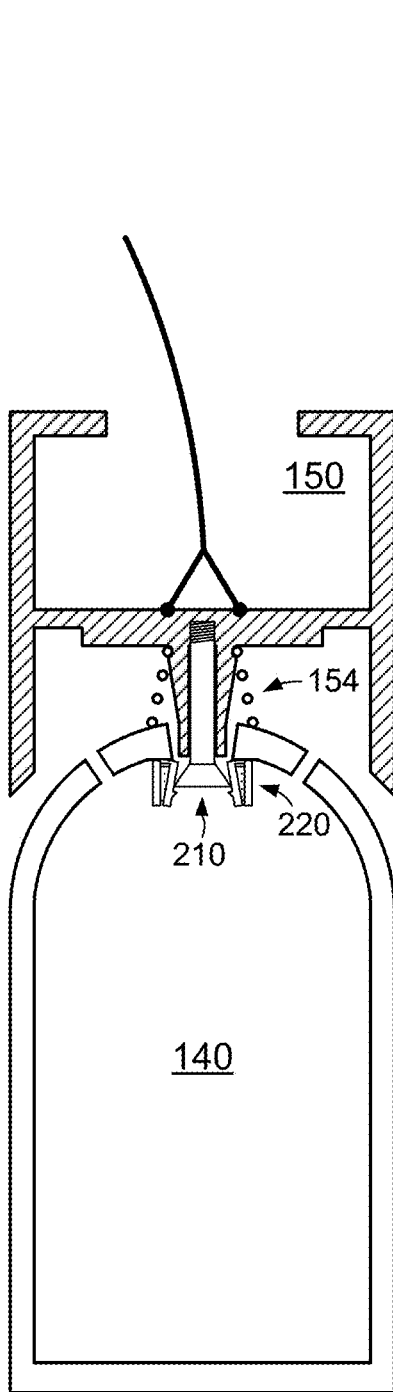

FIG. 5A

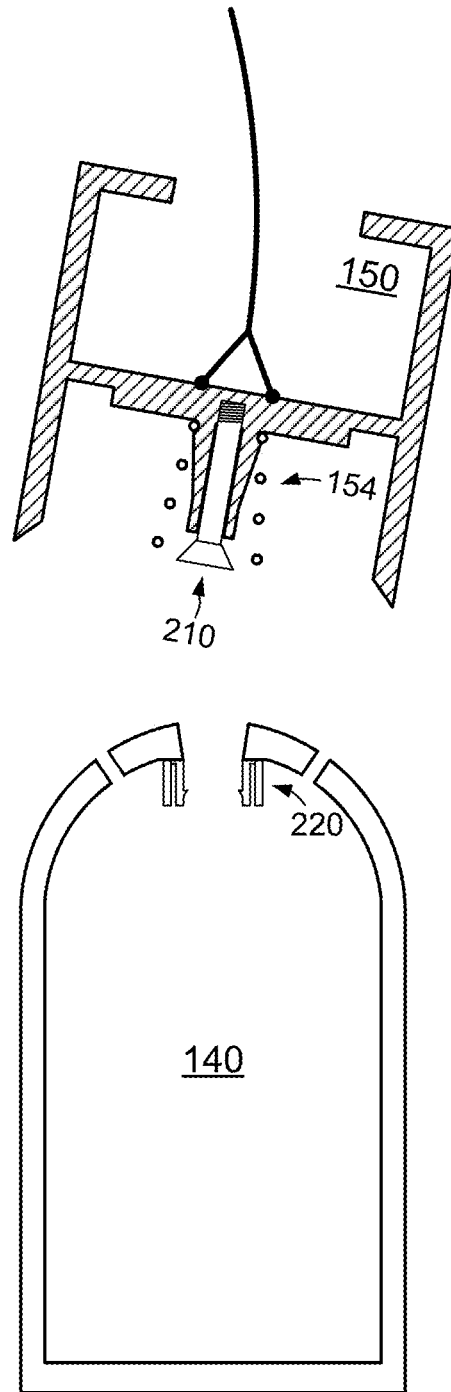

FIG. 5B

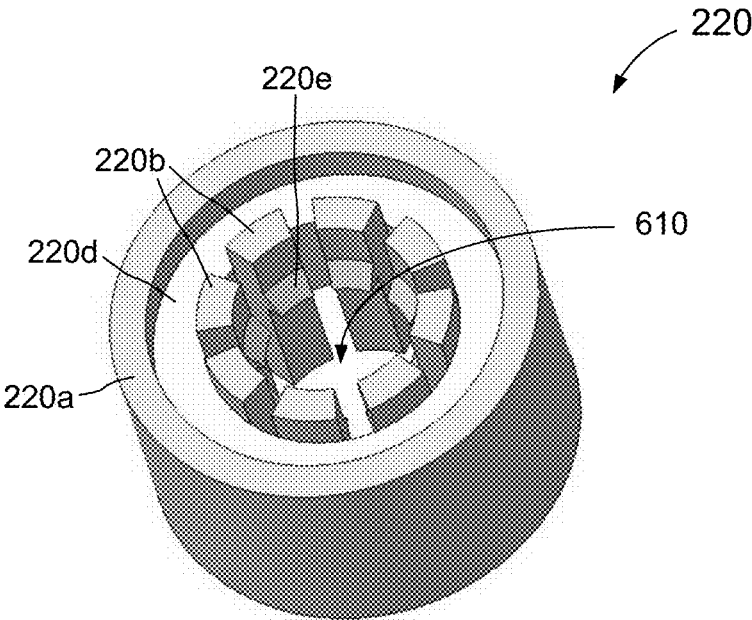

FIG. 6A

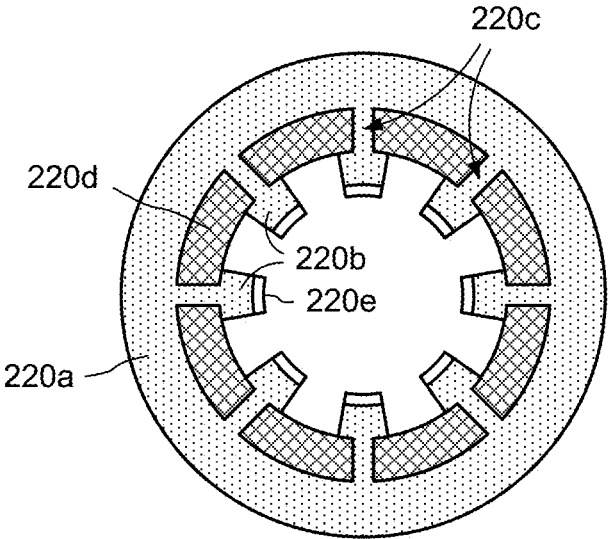

FIG. 6B

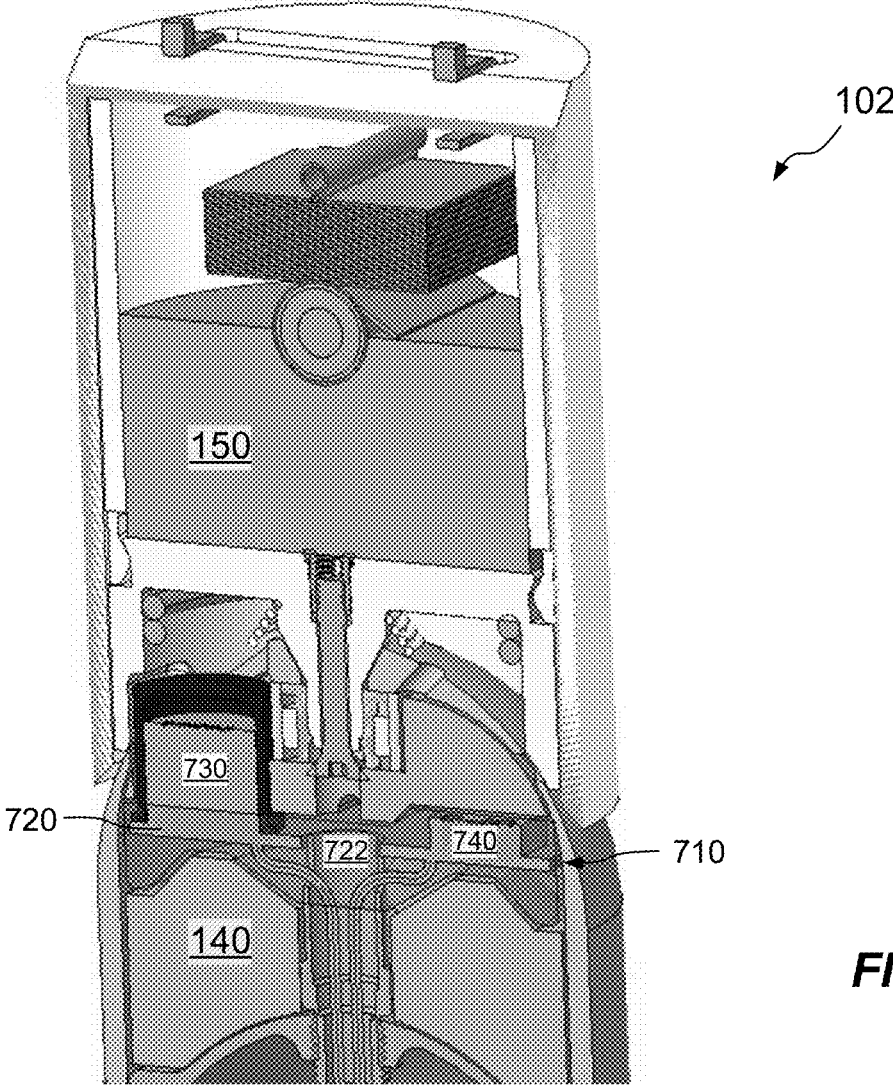

FIG. 7

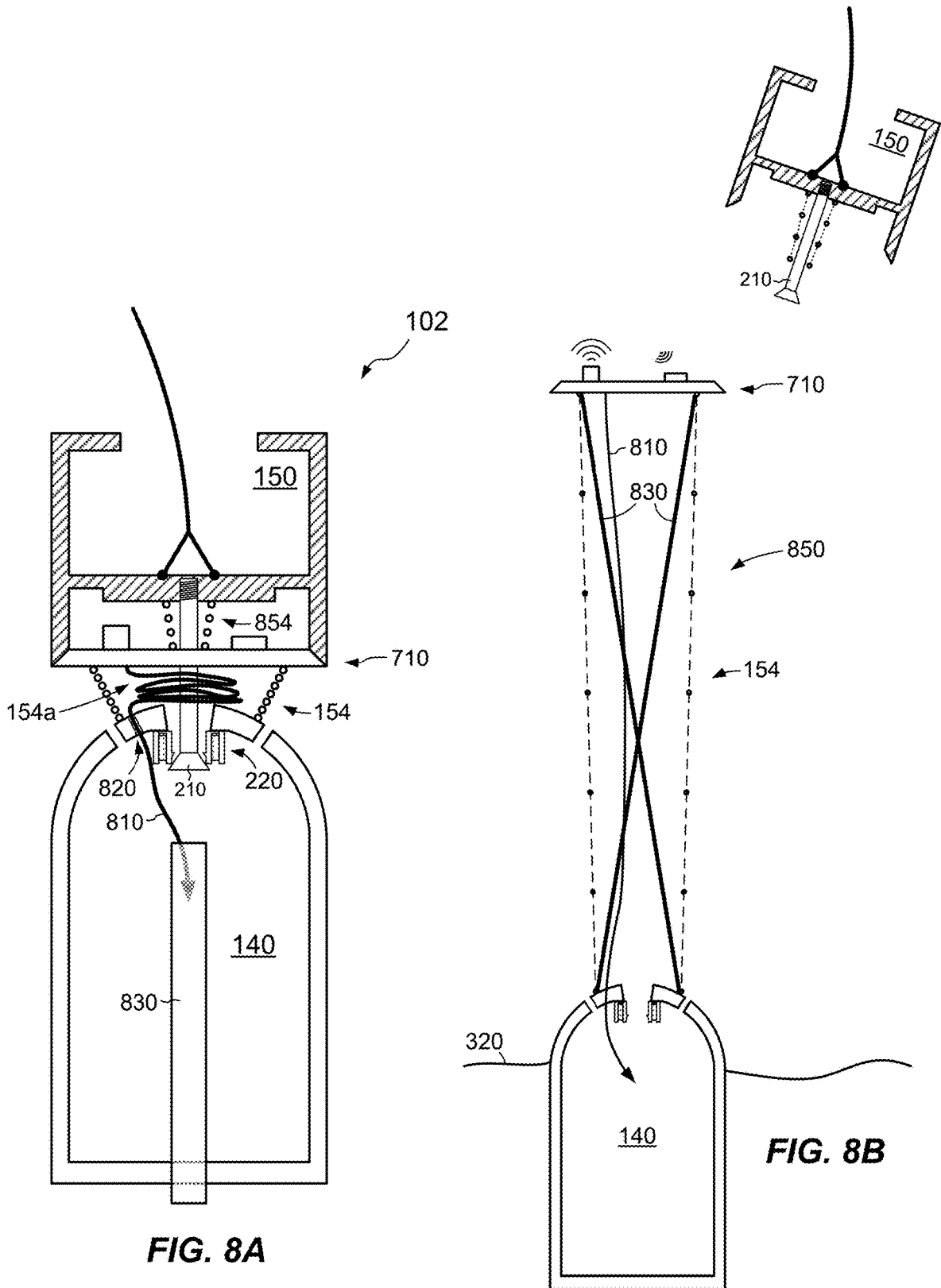

FIG. 8A

FIG. 8B

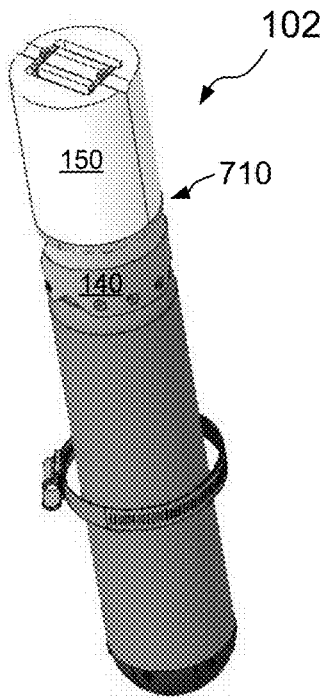

FIG. 9A

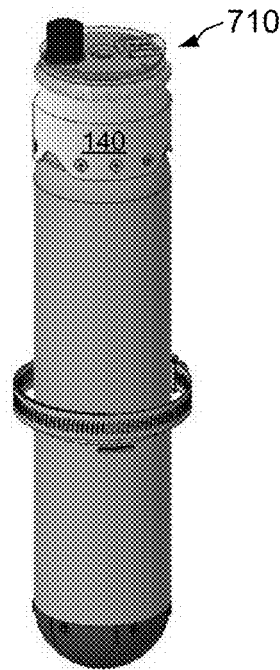

FIG. 9B

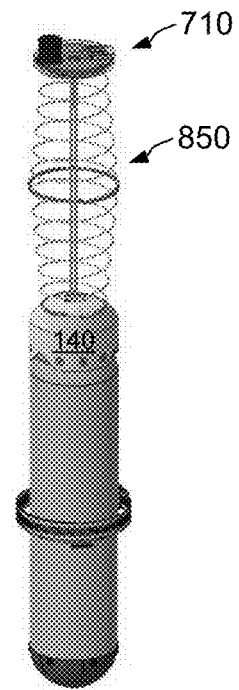
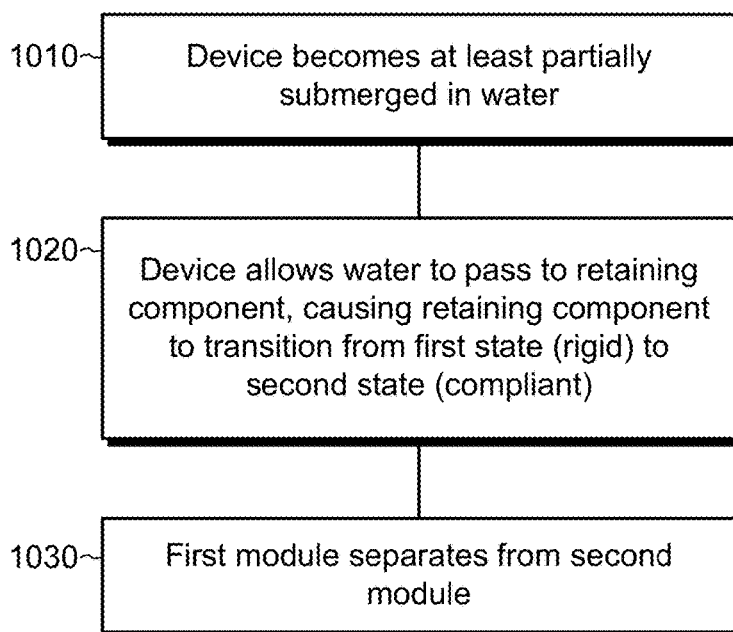

FIG. 9C



1000

FIG. 10

1

**DEVICE WITH WATER-ACTIVATED,
AUTOMATIC DISCONNECT****CROSS-REFERENCE(S) TO RELATED
APPLICATION(S)**

This application claims the benefit of U.S. Provisional Patent Application No. 62/959,513, filed Jan. 10, 2020, the contents and teachings of which are incorporated by reference herein in their entirety.

**STATEMENT REGARDING FEDERALLY
SPONSORED RESEARCH OR DEVELOPMENT**

This invention was made with government support under WC-133R-15-CN-0112 awarded by the National Oceanic and Atmospheric Administration. The government has certain rights in the invention.

BACKGROUND

Hurricanes in the United States cause billions of dollars in damages annually with an average death rate of nearly 20 persons per year. Accurate measurements in and around hurricanes are critical for predicting hurricane intensity, and thus the severity of risks posed to human life and property. Current approaches to measuring hurricane-related factors employ buoys, sondes, and dropsondes. Buoys are floating devices that make measurements near the surface of a body of water and store collected data, which may be retrieved directly by visiting the buoys or by receiving the data over a wireless link. Sondes are devices that operate within a body of water and collect data as they descend. Relevant data may include conductivity, temperature, and depth, for example. Dropsondes are sondes adapted for deployment from an aircraft. A dropsonde can measure atmospheric conditions while falling through the air. After splashdown, a dropsonde can measure water conditions as it sinks through the water. Sondes and dropsondes may log their data while operating under water and transmit the logged data upon resurfacing. Some sondes and dropsondes may perform "profiling," i.e., controllably rising and sinking to various depths and measuring water columns at different locations.

Dropsondes typically deploy parachutes that enable them to fall through the air at controlled speeds and typically jettison their parachutes upon splashdown. For example, a dropsonde may include a sensor that detects sudden deceleration or contact with water and an actuator that detaches the parachute upon such detection.

SUMMARY

Unfortunately, prior disconnect mechanisms for dropsondes and other devices can be expensive and complex. Actuators consume power and valuable space; they also increase weight. Further, the types of devices described above typically operate in wet, saline environments, which can pose short-circuit risks to electronically controlled actuators.

In contrast with prior approaches, an improved technique for managing an attachment between first and second portions of a device includes a retaining component having a first state in which the retaining component maintains the attachment by virtue of a rigid characteristic and a second state in which the retaining component loses the rigid characteristic and no longer maintains the attachment. The retaining component transitions from the first state to the

2

second state upon exposure to liquid water. Advantageously, the improved technique requires no power, sensor, or control circuitry and operates reliably in salt-water environments.

Certain embodiments are directed to an apparatus. The apparatus includes a first portion, a second portion, and a retaining component. The retaining component has a first state and a second state. In the first state, the retaining component is configured to have a rigid characteristic and to hold the first portion to the second portion. In the second state upon exposure to liquid water, the retaining component is configured to lose its rigid characteristic and to free the first portion from the second portion.

Other embodiments are directed to a method of managing an attachment between a first portion and a second portion of a device. The method includes providing a retaining component having a first state and a second state, the retaining component configured in the first state to have a rigid characteristic and to hold the first portion to the second portion, the retaining component configured in the second state to lose its rigid characteristic upon exposure to liquid water. With the retaining component in the first state, the method further includes the device becoming at least partially submerged in water. The method further includes the device allowing water to pass to the retaining component, the retaining component thereupon transitioning from the first state to the second state and freeing the first portion from the second portion.

The foregoing summary is presented for illustrative purposes to assist the reader in readily grasping example features presented herein; however, this summary is not intended to set forth required elements or to limit embodiments hereof in any way. One should appreciate that the above-described features can be combined in any manner that makes technological sense, and that all such combinations are intended to be disclosed herein, regardless of whether such combinations are identified explicitly or not.

**BRIEF DESCRIPTION OF THE SEVERAL
VIEWS OF THE DRAWINGS**

The foregoing and other features and advantages will be apparent from the following description of particular embodiments, as illustrated in the accompanying drawings, in which like reference characters refer to the same or similar parts throughout the different views. The drawings are not necessarily to scale, emphasis instead being placed upon illustrating the principles of various embodiments.

FIG. 1 is a front plan view of an example device in accordance with certain embodiments.

FIG. 2 is a partially exploded view of the device of FIG. 1.

FIG. 3 is a diagram showing an example mission deployment of a device of the kind shown in FIG. 1.

FIG. 4 is a cross-sectional view that shows example parts of the device of FIG. 1, including an example parachute module, communications module, and attachment formed therebetween.

FIGS. 5A and 5B are cross-sectional views that show the parachute module and communications module of FIG. 4 becoming detached.

FIGS. 6A and 6B are perspective and top plan views, respectively, of an example retaining component used in the attachment of FIGS. 4, 5A, and 5B.

FIG. 7 is a perspective sectional view showing an example parachute module, communications module, and attachment.

FIGS. 8A and 8B are cross-sectional views that show an example antenna assembly initially disposed between a parachute module and a communications module (FIG. 8A) and later deployed on a mast (FIG. 8B).

FIGS. 9A-9C are perspective views of another embodiment in which an example antenna assembly is initially disposed between a parachute module and a communications module.

FIG. 10 is a flowchart showing an example method of managing an attachment between first and second portions of a device.

DETAILED DESCRIPTION

Embodiments of the disclosed technique will now be described. One should appreciate that such embodiments are provided by way of example to illustrate certain features and principles but are not intended to be limiting.

A technique for managing an attachment between first and second portions of a device includes a retaining component having a first state in which the retaining component maintains the attachment by virtue of a rigid characteristic of the retaining component and a second state in which the retaining component loses the rigid characteristic and no longer maintains the attachment. The retaining component transitions from the first state to the second state upon exposure to liquid water.

FIG. 1 shows an example device 102 with which embodiments of the improved technique can be practiced. Here, multiple modules 106 are arranged end-to-end along an axis 104 of the device 102. The depicted modules 106 include a nose module 110, a variable buoyancy module 120, an electronics module 130, a communications module 140, and a parachute module 150. Other embodiments may include a greater or fewer number of modules 106, and such modules may be of different types and/or capabilities from those shown. The depicted example is merely illustrative.

FIG. 2 shows the device 102 in additional detail. Here, nose module 110 is seen to include environmental sensors, such as a CTD (conductivity, temperature, and depth) sensor 112, and ballast (e.g., weights) 114. The ballast 114 assists in keeping the nose module 110 pointing down and the device 102 vertical when the device 102 is submerged in water. Nose module 110 has a convex outer surface 116, which may be hemispherically shaped, for example, to enable the device 102 to descend smoothly under water. In some examples, nose module 110 has a concave inner surface 118 adapted for receiving a convex outer surface 126 of variable buoyancy module 120.

Variable buoyancy module 120 is configured to vary its own buoyancy, and hence the buoyancy of the overall device 102, in response to electronic control. To this end, variable buoyancy module 120 enables the device 102 to controllably rise and fall within a water column.

Electronics module 130 is connected to the variable buoyancy module 120 and includes, for example, a power source such as a battery 132 and an electronics assembly 134. As shown, the electronics assembly 134 is electrically connected to the CTD sensor 112 (and any other environmental sensors in the nose module 110), e.g., via a cable that passes through the variable buoyancy module 120. In some examples, the electronics assembly 134 includes a microcontroller, microprocessor, or the like, as well as associated memory. It may further include an IMU (inertial measurement unit) and electronics for supporting GPS, SATCOM, and/or RF communications, such as interfaces to antennas provided in the communications module 140. In some

examples, the power source may be provided in some other module, such as in the variable buoyancy module 120 or in a separate module (e.g., a battery module).

In the example shown, communications module 140 includes a satellite communications (SATCOM) antenna 142 and a GPS (Global Positioning System) antenna 144, which may be electrically connected to the circuit assembly 134 via cables 160. In some examples, one or more RF (Radio Frequency) antennas may be provided, to support RF communication. Communications module 140 may preferably have a convex outer surface 146, e.g., for facilitating upward movement of the device 102 through water. The convex outer surface 146 is preferably made of a non-conductive material, such as poly-vinyl chloride (PVC), to allow electromagnetic signals to readily pass therethrough. The convex outer surface 146 is adapted to mate with a partially-concave inner surface 156 in the parachute module. In some examples, the communications module 140 may include an extendible mast (FIG. 8B) with antennas disposed at a remote end and/or along a length thereof. The extendible mast may serve to raise antennas away from the water surface to improve signal strength.

Parachute module 150 preferably has a detachable connection to communications module 140. As will be described more fully below, a fastener 210 in the communications module 140 attaches to the parachute module 150 and abuts a retaining component 220 that holds the parachute module 150 in place. Spring 154 applies a biasing outward force. The retaining component 220 is configured to soften or dissolve upon contact with liquid water, allowing the spring 154 to pull the fastener 210 through the retaining component 220 and out of the communications module 140, and thus to separate the parachute module 150 from the communications module 140.

FIG. 3 shows an example deployment of a device 102 for making measurements in an aqueous environment. As shown, an airplane or other aircraft 310 drops or otherwise ejects a device 102, which begins falling through the air. Parachute 152 opens, and device 102 begins a slowed descent, falling nose-first, i.e., with nose module 110 pointing down. Depending on application, the device 102 may monitor environmental factors of the air, such as temperature, pressure, humidity, particulate matter, and so forth, as it descends to through the atmosphere. Device 102 may also monitor its own location and altitude, e.g., using GPS. The device 102 may log the results and/or transmit the results, e.g., via SATCOM, to a remote receiver (not shown).

The device 102 eventually splashes down, striking the surface 320 of a body of water. In some examples, the device 102 collects surface data at this time. After exposure to liquid water, the parachute module 150 automatically detaches from the device 102. The device 102 then begins to descend toward the floor 330 of the body of water, leaving the parachute module 150 behind. The device 102 continues to log data as it goes. For example, device 102 may repeatedly measure conductivity, temperature, and depth. Depending on the mission, the device 102 may perform profiling, e.g., by action of the variable buoyancy module 120, alternately ascending and descending and making measurements of different water columns. Once measurements have been made, the device 102 ascends to the surface 320, whereupon the device 102 transmits the contents of its data log wirelessly to a receiver. Alternatively, personnel may retrieve the device 102 and read its data directly.

FIG. 4 shows an example attachment between the communications module 140 and the parachute module 150 in greater detail. The additional modules 106 of FIG. 1 are

5

omitted from the figure for simplicity. In the example shown, the parachute **152** has deployed from the parachute module **150** and the device **102** has landed in water. The parachute **152** remains anchored to the parachute module **150** via a parachute anchor **410**.

As shown in the main figure and in the magnified partial view to the right, the fastener **210** includes a tapered head **210h**, a shaft **210s** that extends from the head **210h**, and threads **210t** formed at a distal end of the shaft **210s**. The threads **210t** engage with a threaded hole **150h** formed within an internal wall **150a** of the parachute module **150**.

In the example shown, the retaining component **220** has an annular shape and a central hole through which the fastener **210** extends. As shown to the right of the figure, the retaining structure **220** includes a frame having an outer wall **220a**, internal fingers **220b**, and spokes **220c**. Contained within the frame is a bobbin pill **220d**. The bobbin pill **220d** is composed of a material that is initially rigid and has high compressive strength, even in humid air, but which softens and/or dissolves when exposed to liquid water. Suitable materials for the bobbin pill **220d** include microcrystalline cellulose. Bobbins of this type are commercially available from numerous sources, including Halkey-Roberts Corporation of St. Petersburg, Fla.

The internal fingers **220b** of the retaining component have internally-projecting steps **220e**. In an assembled state, a cone-shaped projection **150b** from the wall **150a** of the parachute module **150** extends down and rests on the steps **220e**. In this condition, the fastener (e.g., a screw or bolt) may be tightened into the threaded hole in the wall **150a** until the head **210h** of the fastener abuts the internal fingers **220b** of the retaining structure **220**. In this condition, the spring **154** is compressed between a top **140a** of the communications module **140** and the internal wall **150a** of the parachute module **150**. The spring **154** in this example is a conical spring, but other forms of springs may be used. In addition, one should appreciate that the spring **154** may be optional in some embodiments, as mild agitation by waves, wind, and/or currents may be sufficient to separate the two modules without requiring a spring. Also, the spring **154** may be implemented as a magnetic, hydraulic, or pneumatic spring, rather than as a mechanical spring as shown.

In the illustrated arrangement, it is only the retaining structure **220** that prevents the modules **140** and **150** from separating. For example, if the retaining structure **220** were absent, the head of the fastener **210** would pull out of the communications module **140** and the parachute module **150** would float away.

Effectively this action takes place when the device **102** lands in water. Passageways **420** and **422** allow liquid water to enter the top of the communications module **140** and reach the retaining component **220**, bathing the bobbin pill **220d** in water and causing it to lose its initial rigidity, e.g., by dissolving. When the bobbin pill **220d** softens, the internal fingers **220b** splay open, e.g., due to the force of the spring **154** driving the tapered head **210h** of the fastener **210** through the opening at the top of the module **140**. As the retaining component **220** can no longer prevent the modules **140** and **150** from separating, the repulsive force of the spring **154** pushes up on the parachute module **150**, pulling the head **210h** of the fastener **210** completely out of the communications module **140** and freeing the parachute module **150** from the communications module **140**.

One should appreciate that the passageways **420** and **422** normally prevent water from entering the module **140** unless the device **102** is at least partially submerged in water. For example, with the device **102** oriented vertically, as is the

6

case when the device **102** is carried by the parachute **152**, the passageways **422** are angled down so as to prevent raindrops or runoff from rain from entering the module **140**. Rather, it is only when the device **102** is submerged above the level of the passageways **422** that water may enter the module **140**. In some examples, passageways **420** and **422** include baffling to further prevent water entry unless the module **140** is submerged. Such baffling may take the form of partial walls and/or circuitous routes that restrict sloshing and ensure that the retaining structure **220** is exposed to liquid water only in the event of at least partial submergence. Some examples do not require such baffling, however.

FIGS. **5A** and **5B** show various levels of separation. In FIG. **5A**, the head **210h** of the fastener **210** has partially pulled through the retaining component **220**, with the internal fingers **220b** splaying open. Spokes **220c** are easily compressed or pushed aside. As shown in FIG. **5B**, the two modules **140** and **150** have completely separated. Spring **154** is fully extended.

FIGS. **6A** and **6B** show example features of the retaining structure **220** in additional detail. FIG. **6A** is a bottom view and shows the outer wall **220a**, which extends completely around and contains the bobbin pill **220d**, and internal fingers **220b** (8 fingers shown in the figure), which support the bobbin pill **220d** internally. The internal fingers **220b** also provide an abutment for the head of fastener **210**. Each finger **220b** has a respective step **220e**. The retaining structure **220** is seen to have an annular shape and a central hole **610** through which the fastener **210** may pass.

FIG. **6A** is a top view of the retaining structure **220** and further shows spokes **220c**, e.g., one spoke **220c** for each finger **220b**. The spokes **220c** are flexible and easily deformed.

FIG. **7** is a perspective sectional view of an example device **102**, showing an example communications module **140**, parachute module **150**, and attachment therebetween. In this example, the communications module **140** includes an antenna assembly **710**, which includes a substrate **720** (e.g., a circuit board or other carrier), a satellite communications antenna **730** and a GPS (Global Positioning Service) antenna **740**). As shown by non-limiting example, the substrate **720** of the antenna assembly **710** may be disk-shaped and may include a central hole **722**. Certain details of the modules **140** and **150** may differ slightly from those shown in previous figures, underscoring the diversity of embodiments that are contemplated.

FIGS. **8A** and **8B** show yet another embodiment, which may provide for improved signal communications via the antenna assembly **710**. As shown in FIG. **8A**, the antenna assembly **710** is positioned outside the communications module **140**, sandwiched between the two modules **140** and **150**. Cabling **810** (i.e., one or more cables) convey signals from antenna assembly **710** into the communications module **140**, e.g., via a waterproof penetrator **820**, such as a potted bore or a submersible connector. The cabling **810** may further extend into the electronics module **130**, e.g., via a tube **830**. In an example, the cabling **810** is packed inside the spring **154**. For example, the spring **154** has a central region **154a** that can accommodate cabling **810**. The cabling **810** is long enough to reach the parachute module **150** when the spring **154** is fully extended. A somewhat longer version of spring **154** may be provided for this embodiment as compared with the embodiments described above, to support longer extension and to enable the spring **154** to serve as a mast **850**. Also, the spring **154** in this example may have a fixed attachment both to the top of the parachute module **150** and to the antenna assembly **710**.

Optionally, a second spring **854**, such as another conical spring, may be placed between the antenna assembly **710** and the parachute module **150**, to ensure complete separation of the parachute module **150** from the electronics assembly **710** when the parachute module **150** disconnects. The second spring **854** may not be required in certain embodiments, however.

Disconnection of the parachute module **150** proceeds much as described above. For example, the device **102** lands in water. Water enters the communications module **140** and reaches the retaining component **220**. The retaining component **220** transitions upon exposure to liquid water from a first state in which the retaining component **220** is rigid to a second state in which the retaining component loses its rigidity and becomes compliant. Once the retaining component **220** transitions from the first state to the second state, the retaining component **220** can no longer hold back the head of fastener **210**. Under the influence of spring **154**, the head of the fastener pulls through the retaining component **220** and out the top of the communications module **140**.

FIG. **8B** shows an example result of separation. After pulling through the top of the communications module **140**, the fastener **210** pulls through the antenna assembly **710** (FIG. **7**) and is carried away with the parachute module **150**, which fully disconnects from the device **102**. The spring **154** has fully released and forms a mast **850** that extends from the communications module **140** to the antenna assembly **710**. The mast **850** has sufficient length so that it extends above the surface **320** of the water, thus facilitating wireless communications. In some examples, tendons **830** may be provided to reduce lateral flexing of the mast **850**. For example, multiple tendons **830** are disposed within the spring **154** and are arranged to cross. Each of the tendons **830** attaches to the communications module **140** at one end and to the antenna assembly **710** at the other end. The tendons **830** may be composed of an easily-compactable material that resists stretching, such as fabric or string.

FIGS. **9A-9C** show a variant of the embodiment of FIGS. **8A** and **8B**. FIG. **9A** shows the device **102** prior to separation of module **150** from module **140**, with the antenna assembly **710** placed between the two modules. FIG. **9B** shows the device **102** with the parachute module hidden but not separated, revealing more fully the antenna assembly **710**. FIG. **9C** shows the device **102** after the spring **154** has extended to form mast **850** and the parachute module **150** has been jettisoned.

FIG. **10** shows an example method **1000** of managing an attachment between different portions of a device **102** and provides a summary of certain features described above. At **1010**, the device **102** becomes at least partially submerged in water, as shown in FIG. **3**. For example, the device **102** may be a dropsonde deployed from an aircraft. At **1020**, the device **102** allows water to enter the module **140**, e.g., via passageways **420** and **422**, and to pass to the retaining component **220**. Upon exposure to liquid water, the retaining component **220** transitions from the first state, in which the retaining component has a rigid characteristic, to the second state, in which the retaining component loses its rigid characteristic and becomes compliant, e.g., by virtue of the bobbin pill **220d** becoming wet and softening or dissolving. At **1030**, upon the transition from the first state to the second state, the parachute module **150** separates from the communications module **140**, e.g., as a result of the fastener **210** pulling through the retaining component **220** under an imposed force from the spring **154**. The device **102** is then free from the parachute module **150** and is able to descend within the water and to make measurements.

An improved technique has been described for managing an attachment between first and second portions of a device **102**. The technique includes a retaining component **220** having a first state in which the retaining component **220** maintains the attachment by virtue of a rigid characteristic and a second state in which the retaining component **220** loses the rigid characteristic and no longer maintains the attachment. The retaining component **220** transitions from the first state to the second state upon exposure to liquid water. Advantageously, the improved technique requires no power, sensor, or control circuitry and operates reliably in salt-water environments.

Having described certain embodiments, numerous alternative embodiments or variations can be made. For example, although embodiments have been described in which the device **102** is a dropsonde, this is merely an example, as the device **102** may alternatively be a sonde, a buoy, or any device that may be used in an aqueous environment. Further, the depicted separation of a parachute module **150** from a communication module **140** is also merely an example. Thus, separation may be managed between any modules or other portions of the device **102**. The portions need not qualify as modules, per se, and the device **102** need not itself be a modular device. For instance, embodiments may involve disconnecting ballast or payload from the device **102**, or dropping a sensor from a larger module or device.

Although the retaining component **220** has been shown and described as having an annular shape, it may alternatively have different shapes. Further, it is not required that a fastener pull through the retaining component **220**. Rather, the retaining component **220** may be any element having any shape that prevents separation of two portions when dry but allows separation when wet.

Further, although features have been shown and described with reference to particular embodiments hereof, such features may be included and hereby are included in any of the disclosed embodiments and their variants. Thus, it is understood that features disclosed in connection with any embodiment are included in any other embodiment.

As used throughout this document, the words “comprising,” “including,” “containing,” and “having” are intended to set forth certain items, steps, elements, or aspects of something in an open-ended fashion. Also, as used herein and unless a specific statement is made to the contrary, the word “set” means one or more of something. This is the case regardless of whether the phrase “set of” is followed by a singular or plural object and regardless of whether it is conjugated with a singular or plural verb. Also, a “set of” elements can describe fewer than all elements present. Thus, there may be additional elements of the same kind that are not part of the set. Further, ordinal expressions, such as “first,” “second,” “third,” and so on, may be used as adjectives herein for identification purposes. Unless specifically indicated, these ordinal expressions are not intended to imply any ordering or sequence. Thus, for example, a “second” event may take place before or after a “first event,” or even if no first event ever occurs. In addition, an identification herein of a particular element, feature, or act as being a “first” such element, feature, or act should not be construed as requiring that there must also be a “second” or other such element, feature or act. Rather, the “first” item may be the only one. Also, and unless specifically stated to the contrary, “based on” is intended to be nonexclusive. Thus, “based on” should not be interpreted as meaning “based exclusively on” but rather “based at least in part on” unless specifically indicated otherwise. Although certain

embodiments are disclosed herein, it is understood that these are provided by way of example only and should not be construed as limiting.

Those skilled in the art will therefore understand that various changes in form and detail may be made to the embodiments disclosed herein without departing from the scope of the following claims.

What is claimed is:

1. An apparatus, comprising:
 - a first portion;
 - a second portion;
 - a retaining component, the retaining component having a first state and a second state, the retaining component configured to (i) in the first state, have a rigid characteristic and hold the first portion together with the second portion, (ii) transition from the first state to the second state in response to submersion in water, and (iii) in the second state, lose its rigid characteristic and free the first portion from the second portion, wherein the retaining component in the first state is disposed within one of the first portion and the second portion;
 - a set of passageways that allows water to reach the retaining component;
 - a spring disposed between the first portion and the second portion, the spring configured to push the first portion away from the second portion in response to the retaining component transitioning from the first state to the second state; and
 - an antenna assembly disposed between the first portion and the second portion with the retaining component in the first state, the antenna assembly including a set of antennas,
 - wherein the spring has a first end coupled to the antenna assembly and a second end coupled to the second portion, and wherein the antenna assembly is configured to extend away from the second portion but remain attached thereto via the spring in response to the retaining component transitioning from the first state to the second state.
2. The apparatus of claim 1, wherein the retaining component in the first state has a hole therethrough, and wherein the apparatus further comprises a fastener having a head and a shaft, the head abutting the retaining component and the shaft extending through the hole and into the other of the first portion and the second portion, where the shaft is retained therein.
3. The apparatus of claim 2, wherein head of the fastener is configured to pull through the hole in the retaining component in response to the retaining component transitioning from the first state to the second state.
4. The apparatus of claim 3, wherein the retaining component in the first state is disposed within the second portion, and wherein the set of passageways is configured to conduct water to the retaining component in the second portion.
5. The apparatus of claim 4, wherein the apparatus has a vertical orientation, and wherein the passageways are angled downwardly with the apparatus in the vertical orientation to prevent rain water from entering through the passageways while the apparatus falls through air.
6. The apparatus of claim 1, wherein the first portion is a parachute module configured to deploy a parachute coupled to the parachute module, and wherein the retaining component is operative to release the parachute module from the second portion in response to the apparatus landing in water.
7. The apparatus of claim 1, further comprising ballast configured to keep the apparatus vertical in water, and

wherein the antenna assembly is configured to extend out of the water with the spring extended.

8. The apparatus of claim 1, wherein the spring has a central region, and wherein the apparatus further comprises cabling that extends from the antenna assembly, through the central region of the spring, and into the second portion.

9. The apparatus of claim 8, further comprising a set of tendons that pass through the central region of the spring, each of the set of tendons connecting to the antenna assembly at one end and to the second portion at another end, the set of tendons configured to reduce lateral flexing of the spring when the spring is extended.

10. The apparatus of claim 8, further comprising a fastener having a head and a shaft, the shaft passing between the first portion and the second portion and through a hole in the antenna assembly.

11. The apparatus of claim 10, further comprising a second spring disposed between the first portion and the antenna assembly, the second spring configured to push the first portion away from the antenna assembly in response to the retaining component transitioning from the first state to the second state.

12. A method of managing an attachment between a first portion and a second portion of a device, the method comprising:

- providing a retaining component having a first state and a second state, the retaining component configured to (i) in the first state, have a rigid characteristic and hold the first portion together with the second portion, (ii) transition from the first state to the second state in response to submersion in water, and (iii) in the second state, lose its rigid characteristic, wherein the retaining component in the first state is disposed within one of the first portion and the second portion, and wherein the device includes a set of passageways that allows water to reach the retaining component;
- with the retaining component in the first state, the device becoming at least partially submerged in water;
- the device allowing water to pass to the retaining component, the retaining component thereupon transitioning from the first state to the second state and freeing the first portion from the second portion;
- actively pushing the first portion away from the second portion in response to the retaining component transitioning from the first state to the second state; and
- providing an antenna assembly, wherein actively pushing the first portion away from the second portion includes pushing the antenna assembly out of the water.

13. The method of claim 12, wherein the retaining component retains the first portion to the second portion by preventing a fastener from pulling through a hole in the retaining component, and wherein the method further comprises the fastener pulling through the hole in the retaining component in response to the retaining component transitioning from the first state to the second state.

14. The method of claim 12, wherein transitioning from the first state to the second state includes the retaining component or a portion thereof dissolving in water.

15. The method of claim 12, further comprising preventing liquid water from contacting the retaining component until the device is at least partially submerged in the water.

16. The method of claim 12, wherein the first portion is a parachute module, and wherein the retaining component releases the parachute module from the second portion in response to the apparatus becoming at least partially submerged in the water.

17. An apparatus, comprising:

a first portion;

a second portion;

a retaining component, the retaining component having a first state and a second state, the retaining component 5 configured to (i) in the first state, have a rigid characteristic and hold the first portion together with the second portion, (ii) transition from the first state to the second state in response to submersion in water, and 10 (iii) in the second state, lose its rigid characteristic and free the first portion from the second portion, wherein the retaining component in the first state is disposed within one of the first portion and the second portion;

a set of passageways that allows water to reach the retaining component; and 15

a set of antennas coupled to a spring disposed between the first portion and the second portion, the spring configured to push the first portion away from the second portion and to push the set of antennas out of the water in response to the retaining component transitioning 20 from the first state to the second state.

18. The apparatus of claim **17**, wherein the spring has a first end coupled to the set of antennas and a second end coupled to the second portion, and wherein the set of antennas is configured to extend away from the second 25 portion but remain attached thereto via the spring in response to the retaining component transitioning from the first state to the second state.

19. The apparatus of claim **17**, further comprising ballast configured to keep the apparatus vertical in the water when 30 the spring is extended.

* * * * *