



US011560204B2

(12) **United States Patent**
Cardenas et al.

(10) **Patent No.:** **US 11,560,204 B2**

(45) **Date of Patent:** **Jan. 24, 2023**

(54) **TECHNIQUES FOR PROVIDING VARIABLE BUOYANCY TO A DEVICE**

USPC 441/1, 21, 28, 29
See application file for complete search history.

(71) Applicant: **Boston Engineering Corporation,**
Waltham, MA (US)

(56) **References Cited**

(72) Inventors: **Robert Lee Cardenas,** Framingham, MA (US); **Michael Conry,** Beverly, MA (US); **Michael Rufo,** Hanover, MA (US); **Todd Scrimgeour,** Brighton, MA (US)

U.S. PATENT DOCUMENTS

3,171,376	A	3/1965	Michael et al.	
3,818,523	A	6/1974	Stillman	
3,906,565	A	9/1975	Dorrance et al.	
5,460,556	A *	10/1995	Logan	B63B 22/18
				441/32
6,309,269	B1 *	10/2001	Fulton	B63B 21/22
				441/6
6,772,705	B2	8/2004	Leonard et al.	
6,807,856	B1	10/2004	Webb	
6,916,219	B2 *	7/2005	Tokhtuev	G01N 1/14
				441/29
8,397,658	B1	3/2013	Imlach et al.	
9,272,756	B1 *	3/2016	Thomson	B63B 22/18
10,569,839	B1 *	2/2020	Thomson	B63B 22/12
2014/0047682	A1	2/2014	Blackman et al.	

(73) Assignee: **Boston Engineering Corporation,**
Waltham, MA (US)

(*) Notice: Subject to any disclaimer, the term of this patent is extended or adjusted under 35 U.S.C. 154(b) by 129 days.

(21) Appl. No.: **17/122,527**

(22) Filed: **Dec. 15, 2020**

(65) **Prior Publication Data**

US 2021/0179234 A1 Jun. 17, 2021

Related U.S. Application Data

(60) Provisional application No. 62/959,513, filed on Jan. 10, 2020, provisional application No. 62/948,514, filed on Dec. 16, 2019.

(51) **Int. Cl.**
B63B 22/20 (2006.01)
B63B 79/40 (2020.01)

(52) **U.S. Cl.**
CPC **B63B 22/20** (2013.01); **B63B 79/40** (2020.01)

(58) **Field of Classification Search**
CPC B63B 22/00; B63B 22/12; B63B 22/18; B63B 22/20; B63B 22/24; B63B 79/00; B63B 79/40; B63B 2211/02

FOREIGN PATENT DOCUMENTS

RU	2609849	2/2017
WO	2012013962	2/2012
WO	2018067738	4/2018

Primary Examiner — Daniel V Venne

(74) *Attorney, Agent, or Firm* — BainwoodHuang

(57) **ABSTRACT**

A variable buoyancy device has an inner region and an outer cavity. The outer cavity extends at least partially around the inner region and is adapted to contain fluids, such as a liquid and a gas, the relative proportions of which can be varied to vary buoyancy. The inner region provides an advantageous location for equipment, while the outer cavity provides a significant volume for achieving a wide range of buoyancy adjustments.

20 Claims, 6 Drawing Sheets

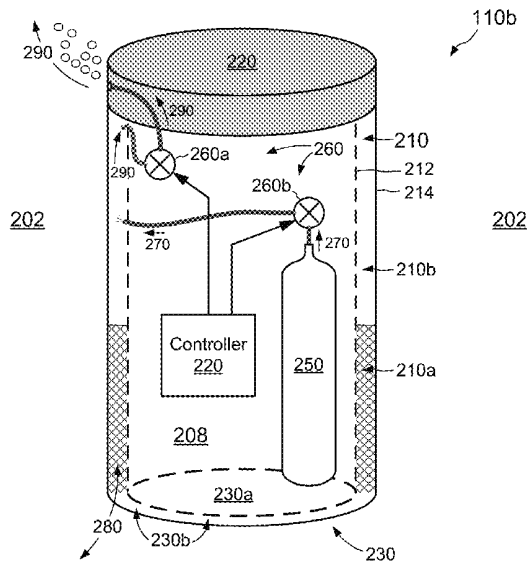

(56)

References Cited

U.S. PATENT DOCUMENTS

2017/0227638 A1 8/2017 Nicoletti et al.
2018/0162501 A1 6/2018 Peterson et al.

* cited by examiner

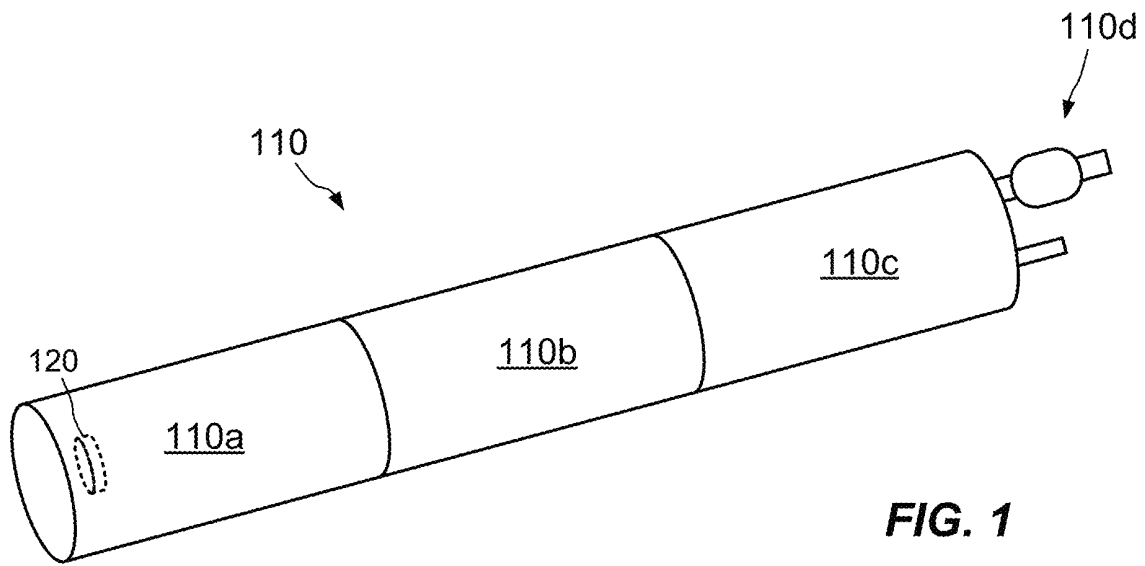

FIG. 1

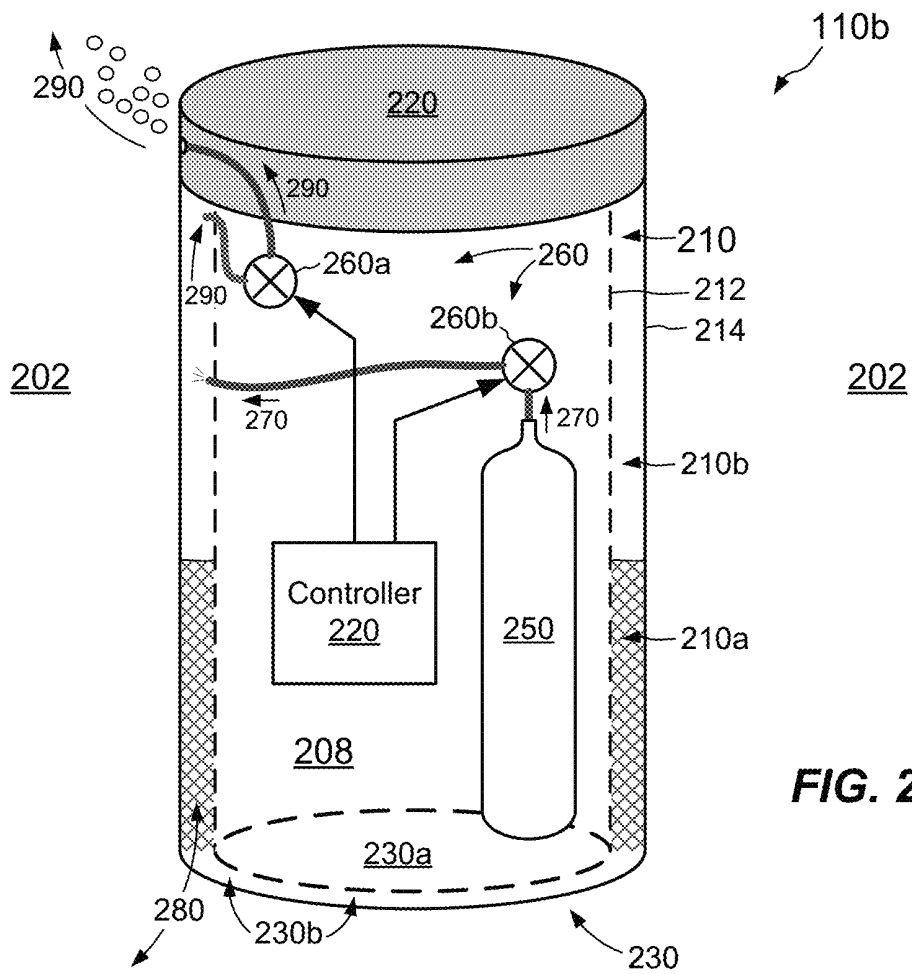

FIG. 2

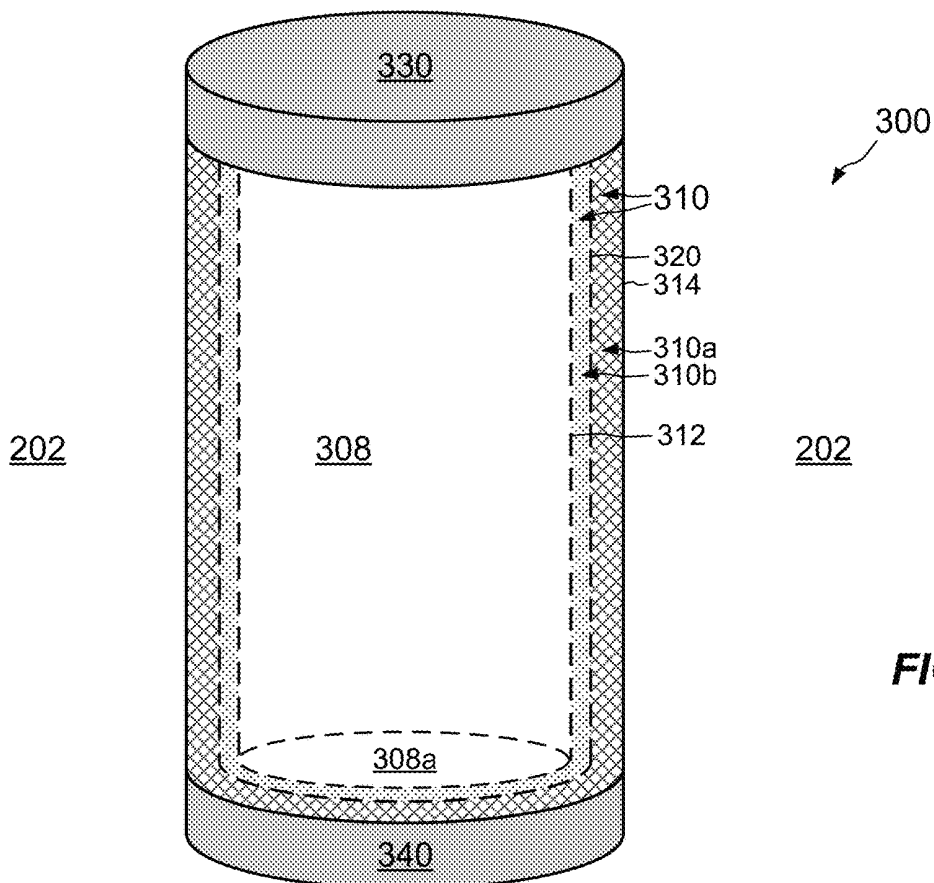

FIG. 3

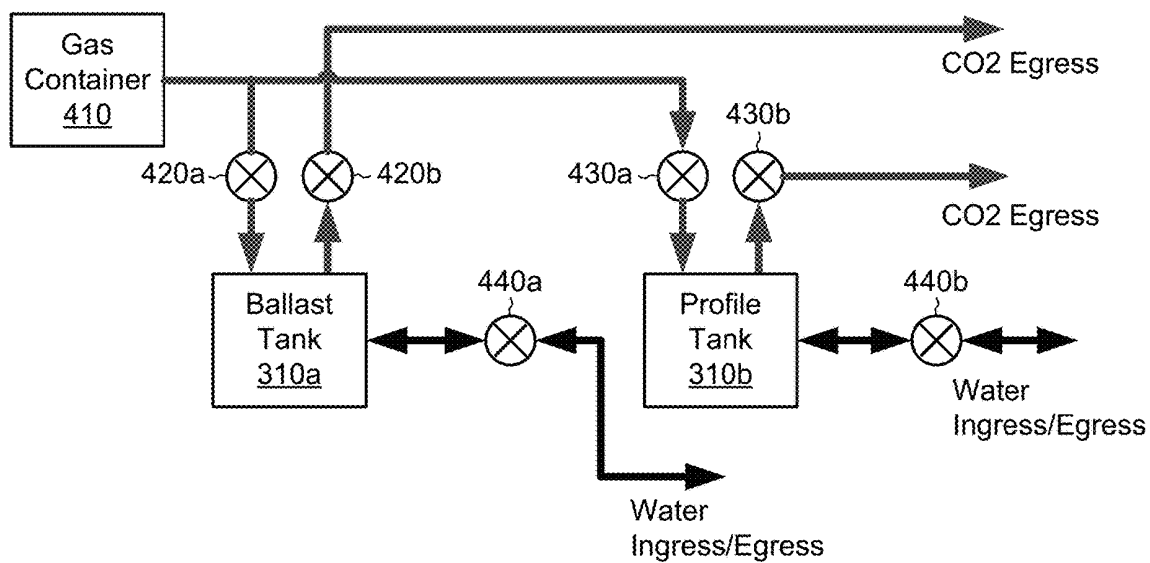

FIG. 4

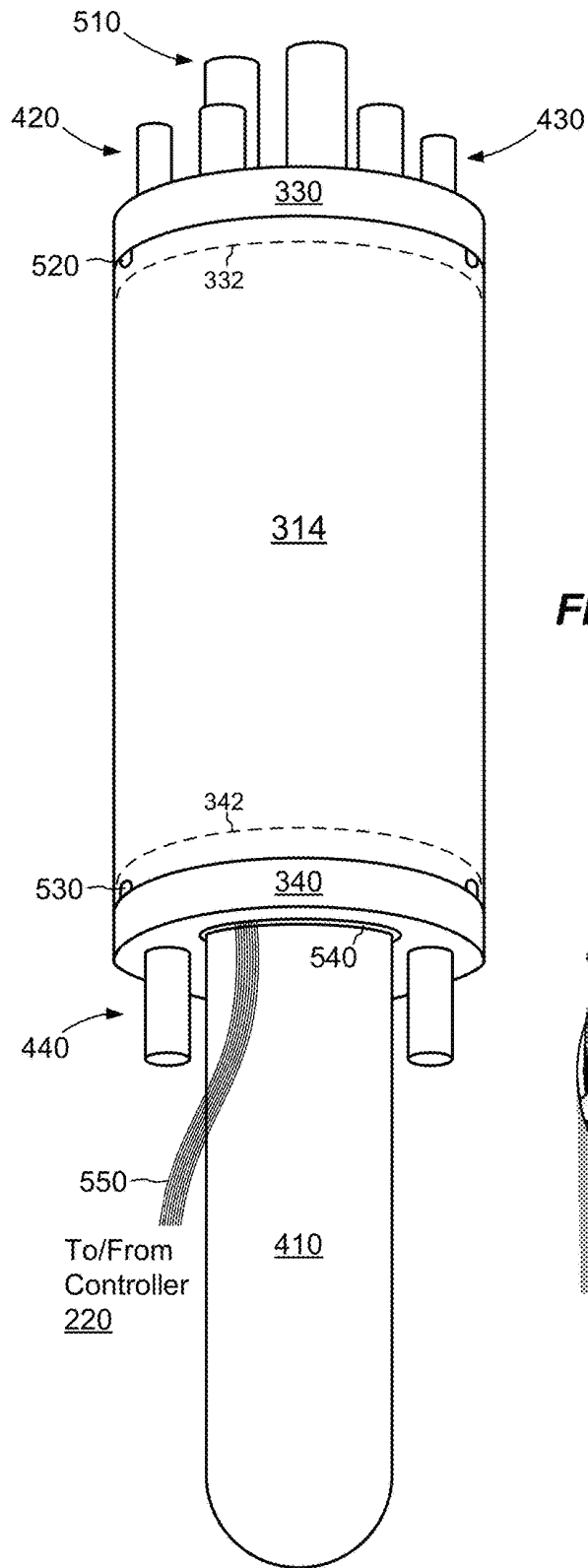

FIG. 5

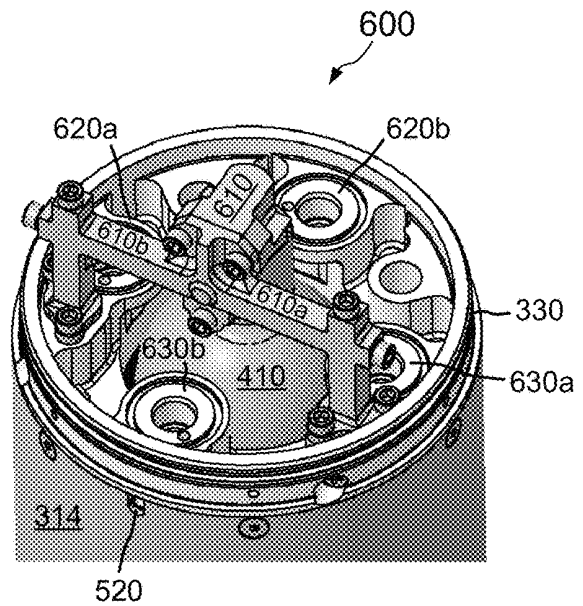

FIG. 6

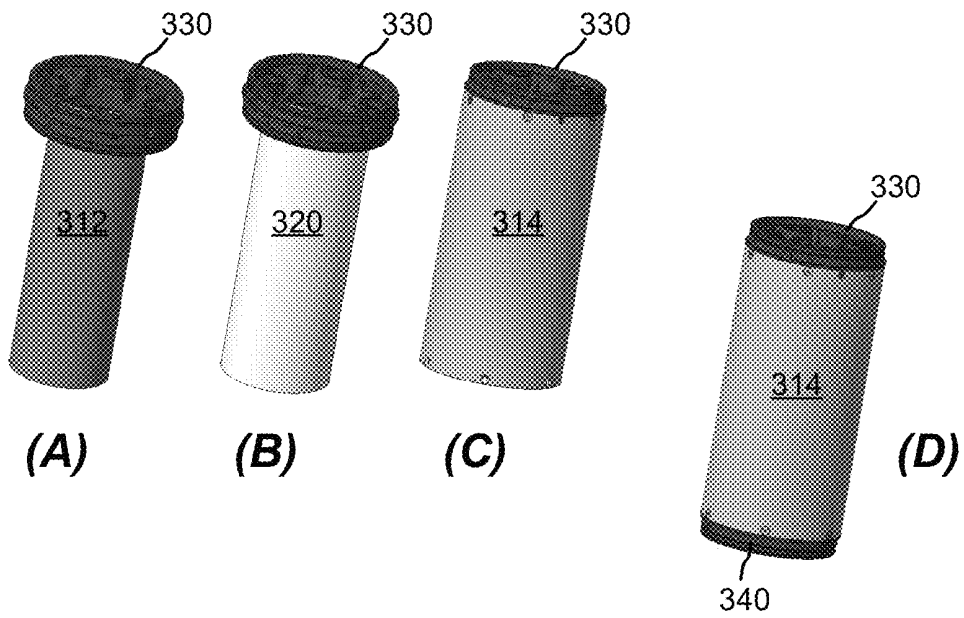

FIG. 7

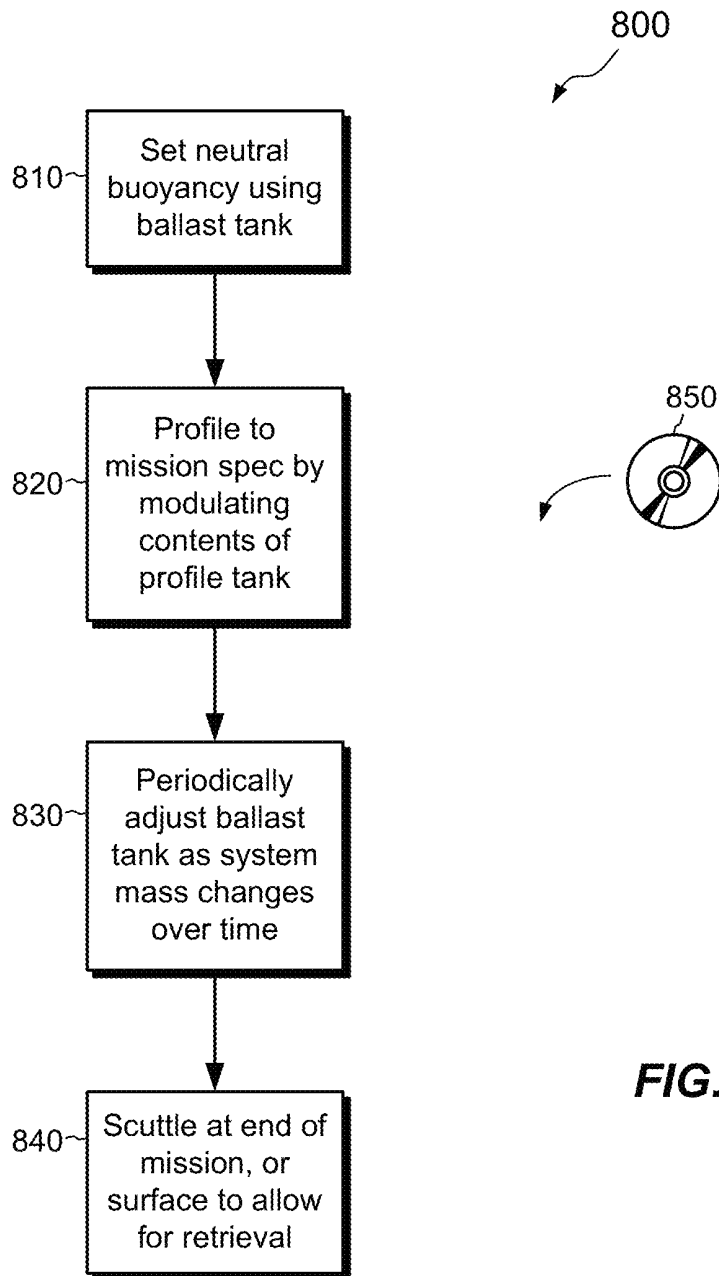

FIG. 8

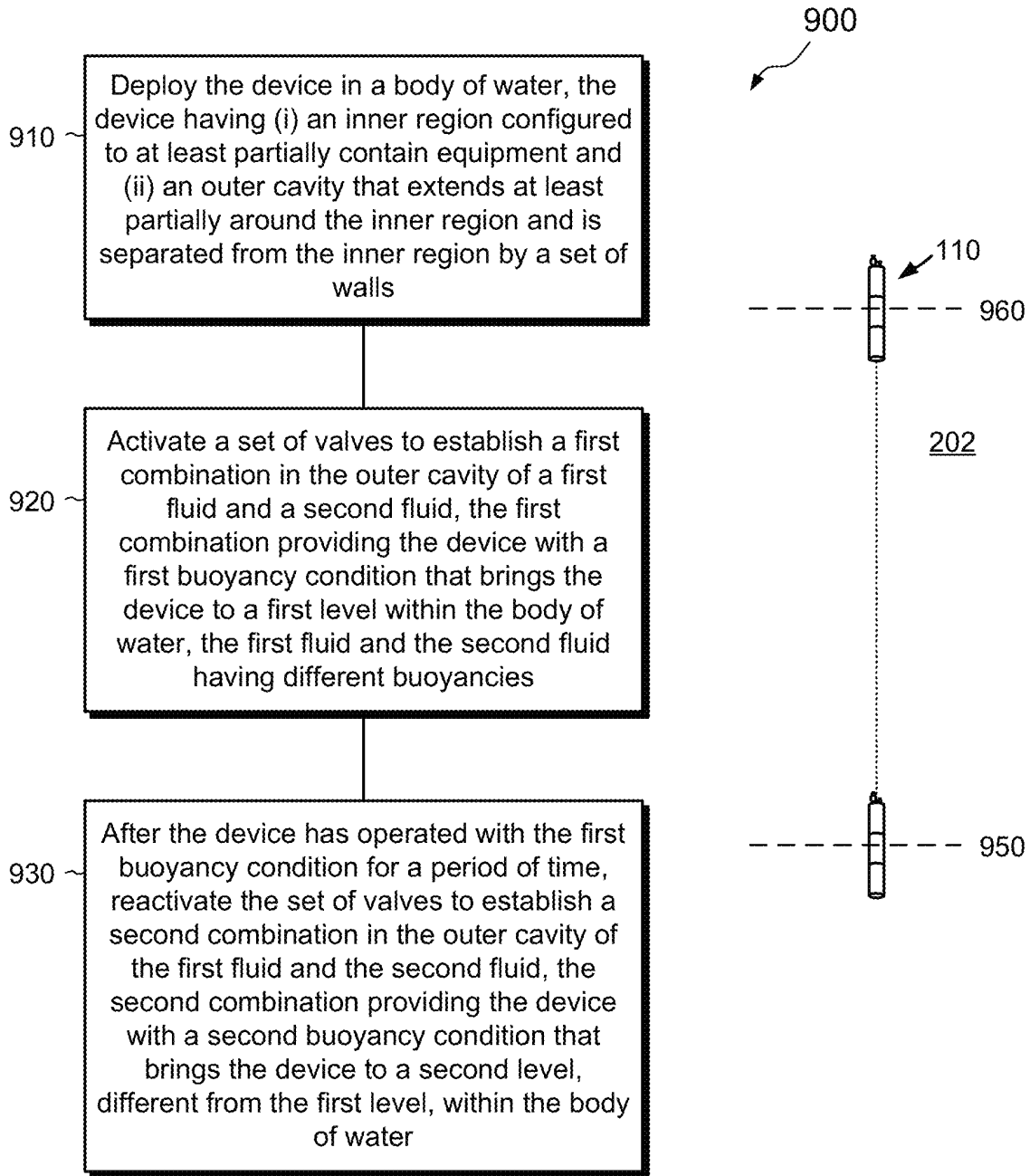

FIG. 9

TECHNIQUES FOR PROVIDING VARIABLE BUOYANCY TO A DEVICE

CROSS-REFERENCE TO RELATED APPLICATIONS

This application claims the benefit of U.S. Provisional Application No. 62/948,514, filed Dec. 16, 2019, the contents and teachings of which are incorporated herein by reference. This application also claims the benefit of U.S. Provisional Application No. 62/959,513, filed Jan. 10, 2020, the contents and teachings of which are incorporated herein by reference.

STATEMENT REGARDING FEDERALLY SPONSORED RESEARCH OR DEVELOPMENT

This invention was made with government support under WC-133R-15-CN-0112 awarded by the National Oceanic and Atmospheric Administration. The government has certain rights in the invention.

BACKGROUND

Changing the buoyancy of an apparatus within a fluid, such as water or air, has long been a necessary activity in many areas, such as maritime and aviation technologies. Submarines, air balloons, dirigibles, and the like use ballasts, hot air, compressed gas, hydrogen, and/or helium to vary altitude in the atmosphere or depth within water. For maritime uses, gases such as helium, hydrogen, and carbon dioxide may be stored in compressed form, e.g., in storage tanks or cartridges, and released to lower-pressure states as needed to increase buoyancy.

A sonde is a submersible apparatus that can travel up and down within a body of water and make measurements, such as measurements of temperature, pressure, and/or salinity. A sonde may travel up and down at numerous locations, in a process called "profiling." A conventional sonde may include a centrally-located tank, such as a bladder, which is adapted to hold both water (or other liquid) and gas. To make the sonde sink, the tank is filled with water. To make the sonde rise, the tank is filled with gas.

SUMMARY

Unfortunately, the central tank of the above-described sonde tends to consume significant interior volume. Also, the central location of the tank can impose constraints and/or restrictions on the placement of other onboard equipment. Accordingly, the conventional sonde may require customized frames, housings, awkwardly located equipment, inefficiently packaged or implemented electrical systems, etc., depending on the specific type of application and/or use. For some situations, the central location of the tank may even make the sonde unsuitable for use.

In contrast with the above-described conventional sonde, improved techniques involve the use of a variable buoyancy device having an inner region and an outer cavity. The outer cavity extends at least partially around the inner region and is adapted to contain fluids, such as a liquid and a gas, the relative proportions of which can be varied to vary buoyancy. The inner region provides an advantageous location for equipment, while the outer cavity provides a significant volume for achieving a wide range of buoyancy adjustments. The improved techniques enable the variable buoyancy device to have a non-intrusive form factor (e.g., a slim

or streamline body) with gas and/or liquid held efficiently in the outer cavity outside the inner region.

Certain embodiments are directed to a variable buoyancy device. The device includes an inner region, configured to at least partially contain equipment, and an outer cavity that extends at least partially around the inner region and is separated from the inner region by a set of walls. The device further includes a set of valves and a controller coupled to the set of valves. The controller is constructed and arranged to activate the set of valves to establish a first combination of a first fluid and a second fluid in the outer cavity, the first combination providing the device with a first buoyancy condition. The controller is further constructed and arranged to reactivate the set of valves to establish a second combination of the first fluid and the second fluid in the outer cavity, the second combination providing the device with a second buoyancy condition. The first fluid and the second fluid have different relative buoyancies.

In some arrangements, the set of valves includes a first valve coupled between the outer cavity and an environment of the device, where the first fluid is obtained from the environment of the device, and a second valve coupled between the outer cavity and a source of the second fluid.

In some arrangements, the first fluid comprises a liquid and the second fluid comprises a gas.

In some arrangements, the source of the second fluid includes a container of compressed gas.

In some arrangements, the outer cavity extends at least partially along the device lengthwise and at least partially around the device transversely.

In some arrangements, the outer cavity has a closed top and an open bottom open to the environment of the device.

In some arrangements, the outer cavity includes a first region and a second region that provide respective enclosed spaces. The first region and the second region are configured to contain respective combinations of the first fluid and the second fluid.

In some arrangements, the set of valves is configured to independently control the respective combinations in the first region and the second region.

In some arrangements, the first region is external to the second region and is larger in volume than the second region.

In some arrangements, the outer cavity has an annular cross-section over at least a portion of its length, and the first region and the second region are separated at least in part by a cylindrical wall within the outer cavity.

In some arrangements, the container of compressed gas is at least partially disposed in the inner region as equipment of the device.

Other embodiments are directed to a sonde that includes multiple modules arranged end-to-end. The modules include a variable buoyancy module, such as the variable buoyancy module described above.

Still other embodiments are directed to a method of changing buoyancy of a device. The method includes deploying the device in a body of water, the device having (i) an inner region configured to at least partially contain equipment and (ii) an outer cavity that extends at least partially around the inner region and is separated from the inner region by a set of walls. The method further includes activating a set of valves to establish a first combination in the outer cavity of a first fluid and a second fluid, the first combination providing the device with a first buoyancy condition that brings the device to a first level within the body of water. The first fluid and the second fluid have different buoyancies. After the device has operated with the

3

first buoyancy condition for a period of time, the method still further includes reactivating the set of valves to establish a second combination in the outer cavity of the first fluid and the second fluid, the second combination providing the device with a second buoyancy condition that brings the device to a second level, different from the first level, within the body of water.

In some arrangements, the first fluid is water provided from the body of water, and activating the set of valves causes a volume of water from the body of water to enter the outer cavity.

In some arrangements, the second fluid is gas provided from a container of compressed gas, and reactivating the set of valves causes a quantity of gas from the container to enter the outer cavity and a quantity of water to be displaced from the outer cavity.

In some arrangements, the outer cavity includes first and second regions that provide respective enclosed spaces, and the method further includes: establishing a ballast setting of the device by providing a set combination of water and gas in the first region of the outer cavity; and varying a depth of the device in the body of the water by varying a combination of water and gas in the second region of the outer cavity while maintaining constant the set combination of water and gas in the first region.

In some arrangements, providing the set combination includes establishing neutral buoyancy of the device in the body of water.

In some arrangements, providing the set combination includes introducing water into the first region by: opening a first valve coupled between the first region and the body of water; and opening a second valve coupled between an upper portion of the first region and the body of water.

In some arrangements, establishing the ballast setting of the device includes introducing gas into the first region by: opening a first valve coupled between the first region and the body of water; and opening a third valve coupled between the first region and the container of compressed gas.

In some arrangements, varying the depth of the device further includes increasing the buoyancy of the device by: opening a fourth valve coupled between a lower portion of the second region and the body of water; and opening a fifth valve coupled between the second region and the container of compressed gas. Opening the fourth valve and the fifth valve displaces a volume of water in the second region with a volume of gas.

In some arrangements, varying the depth of the device includes decreasing the buoyancy of the device by: opening the fourth valve; and opening a sixth valve coupled between the second region and the body of water. Opening the fourth valve and the sixth valve displaces a volume of gas in the second region with a volume of water.

The foregoing summary is presented for illustrative purposes to assist the reader in readily grasping example features presented herein; however, this summary is not intended to set forth required elements or to limit embodiments hereof in any way. One should appreciate that the above-described features can be combined in any manner that makes technological sense, and that all such combinations are intended to be disclosed herein, regardless of whether such combinations are identified explicitly or not.

BRIEF DESCRIPTION OF THE SEVERAL VIEWS OF THE DRAWINGS

The foregoing and other features and advantages will be apparent from the following description of particular

4

embodiments, as illustrated in the accompanying drawings, in which like reference characters refer to the same or similar parts throughout the different views. The drawings are not necessarily to scale, emphasis instead being placed upon illustrating the principles of various embodiments.

FIG. 1 is a block diagram of an example sonde with which embodiments of the improved techniques can be practiced.

FIG. 2 is a schematic view of an example variable buoyancy device in accordance with one embodiment.

FIG. 3 is a schematic view of an example variable buoyancy device in accordance with another embodiment.

FIG. 4 is a schematic diagram of an example arrangement of valves in the embodiment of FIG. 3.

FIG. 5 is a lower-front view of the example variable buoyancy device of FIG. 3.

FIG. 6 is a partial top-front view of the example variable buoyancy device of FIG. 3.

FIG. 7 is a series of views showing an example order of assembly of the variable buoyancy device of FIG. 3.

FIG. 8 is a flowchart showing an example method of changing buoyancy of a device.

FIG. 9 is a flowchart showing an example method of using the variable buoyancy device of FIG. 3.

DETAILED DESCRIPTION

Embodiments of the improved techniques will now be described. One should appreciate that such embodiments are provided by way of example to illustrate certain features and principles but are not intended to be limiting.

Improved techniques are directed to a variable buoyancy device having an inner region and an outer cavity. The outer cavity extends at least partially around the inner region and is adapted to contain fluids, such as a liquid and a gas, the relative proportions of which can be varied to vary buoyancy. The inner region provides an advantageous location for equipment, while the outer cavity provides a significant volume for achieving a wide range of buoyancy adjustments.

FIG. 1 shows an example sonde **110** with which embodiments of the improved techniques can be practiced. The sonde **110** is seen to include multiple modules, e.g., modules **110a**, **110b**, and **110c**, which are arranged end-to-end. For example, module **110a** is a sensor module, module **110b** is a variable buoyancy module, and module **110c** is an electronics or parachute module. Although a variable buoyancy module **110b** is assumed to be present in all disclosed embodiments, other types of modules may be used in place of or in addition to the modules **110a** and **110c**, such as a battery module, a communications module, or other types of modules.

In an example, the sonde **110** is deployable from an aircraft over a body of water, such as an ocean, lake, river, sea, or the like. For instance, the sonde **110** is dropped from an aircraft and releases a parachute (not shown). Upon splashdown, the sonde detaches from the parachute and prepares for profiling, i.e., repetitively descending and rising within the body of water. A weight **120** may be placed within the bottom-most module (e.g., **110a**), to keep the sonde **110** in an upright orientation in the water. While profiling, instrumentation within the sonde **110** typically makes measurements of the environment, such as temperature, pressure, salinity, and the like, and stores the measurements internally, e.g., in computer memory or non-volatile storage, such as a magnetic disk drive or electronic flash drive. When the sonde eventually surfaces, it may transmit the measure-

ments wirelessly to a base station, which may be located on a ship, on an aircraft, or on land, for example.

In order to efficiently profile within the body of water, the sonde 110 preferably varies its own buoyancy, e.g., by decreasing its buoyancy to sink and increasing its buoyancy to rise. In the illustrated example, the role of varying the buoyancy of the sonde 110 is performed by the variable buoyancy module 110b.

FIG. 2 shows a first example of a variable buoyancy device 200 according to certain embodiments. The variable buoyancy device 200 may constitute the variable buoyancy module 110b or only a portion thereof. As shown, the variable buoyancy device 200 includes an inner region 208 and an outer cavity 210. A set of walls, such as wall 212, separates the inner region 208 from the outer cavity 210. The outer cavity 210 also has an external wall 214. The inner region 108 may be configured to at least partially house various equipment, such as a controller 220 (e.g., a micro-controller and/or other electronic control circuitry), a container 250 of compressed gas (such as CO₂), and various valves 260. A first valve 260a is coupled between an upper portion of the outer cavity 210 and an environment 202 of the sonde 110, such as a body of water or other liquid that surrounds the sonde 110 (Water is assumed going forward, but it is understood that embodiments are not limited to use in water). A second valve 260b is coupled between the container 250 and the outer cavity 210. The illustrated tubes may be used to conduct fluids through the indicated paths 270 and 290. One or more manifolds may also be used for this purpose.

In the illustrated example, the inner region 208 is preferably enclosed, so that no gas or water may enter or exit. One or more airtight, watertight ports (not shown) may be provided to facilitate service of equipment within the inner region 208.

The variable buoyancy device 200 is seen to have a closed top 220 and a partially open bottom 230. The top 220 preferably forms an airtight and watertight seal with the walls 212 and 214, such that the outer cavity 210 may contain a volume of gas and water when the variable buoyancy device 200 is submerged and oriented upright (as shown). The bottom 230 of the variable buoyancy device 200 has a closed region 230a, which forms a bottom of the inner region 208, and an open region 230b, which forms a passageway between the environment 202 and the outer cavity 210. Thus, the top of the outer cavity 210 is closed while the bottom of the outer cavity 210 is open, allowing water 210a to freely enter and exit the outer cavity 210. The amount of water 210a in the outer cavity 210 may be limited by the volume of gas 210b contained in the outer cavity 210.

The variable buoyancy device 200 preferably has a rigid construction, with walls 212 and 214, top 220, and bottom 230a made of one or more rigid materials, such as aluminum and/or CPVC (chlorinated polyvinyl chloride). Other materials may also be used, once due consideration is given to cost, rigidity, tolerance to water, and weight. For example, the materials should not be so dense that excessive amounts of gas are required to lift the sonde 110 within water.

In example operation, the variable buoyancy device 200 begins a profiling cycle by reducing its buoyancy. For instance, the controller 220 activates valve 260a to open and valve 260b to close (both valves 260 may be normally-closed). Ambient water pressure then causes water 210a to enter the outer cavity 210 via path 280 at the bottom portion 230b while gas 210b within the outer cavity 210 begins to escape via path 290 into the environment 202, e.g., surrounding water.

It may not be necessary or desirable to evacuate all gas 210b from the outer cavity 210. Rather, in some examples the controller 220 opens the valve 260a in timed pulses, with each pulse releasing an increment of gas. The controller 220 may repeat this pulsing until the sonde 110 begins to descend, or until the sonde 110 achieves a desired rate of descent.

As a result of activating the valves 260 in the manner described, the variable buoyancy device 200 achieves a first buoyancy condition based on a first combination of water 210a (a first fluid) with gas 210b (a second fluid). Water has lower buoyancy than gas, and thus increasing the amount of water relative to the amount of gas in the outer cavity 210 has the effect of decreasing the buoyancy of the variable buoyancy device 200 and thus of the sonde 110 as a whole.

As the sonde 110 sinks, it may make numerous measurements of depth, temperature, salinity, and the like. The sonde 110 may store the measurements internally.

Once the sonde 110 has reached a desired depth, controller 220 may stop or reverse the descent by releasing an amount of gas from container 250 into the outer cavity 210. To this end, controller 220 reactivates the valves by opening valve 260b and closing valve 260a, which may already be closed. Gas 210b then enters the outer cavity 210, via path 270. As gas enters, the volume of gas 210b in the outer cavity 210 increases, causing a volume of water 210a to escape from the open bottom 230b into the environment, via path 280. As before, the controller 220 may use timed pulses, accumulating gas 210b in the outer cavity 210 until descent is stopped, or until a desired rate of ascent is achieved. The variable buoyancy device 200 thus assumes a second buoyancy condition based on a second combination of water 210a with gas 210b.

In some examples, the controller 220 may allow the sonde 110 to descend to a set depth, and to remain at this depth for a period of time before rising. A reason to descend and maintain depth is to ensure that the sonde falls below a level at which sunlight can typically reach. Maintaining depth in this manner can prevent biofouling, which can have an adverse effect on sonde operation. When it is time to ascend, the controller 220 may continue as before, i.e., by opening valve 260b (with valve 260a still closed). The sonde 110 may make additional measurements while it is rising.

The sonde 110 may perform numerous profiling cycles in this manner, falling and rising through the water based on operation of the controller 220 to activate the valves 260 as described. After each cycle, or after some number of cycles, the sonde 110 may rise to the surface and transmit its measurements to a base station. At the end of its mission, the sonde 110 may be retrieved. It may alternatively be scuttled, i.e., allowed to sink to the bottom of the body of water. The controller 220 may scuttle the sonde 110 by opening both valves 260 and keeping them open, e.g., until the container 250 runs out of compressed gas and the sonde 110 sinks to the bottom under its own weight.

The variable buoyancy device 200 thus embodies an efficient and cost-effective design for profiling a sonde in water while assuming a convenient form factor. It provides an ample inner region 208 for housing equipment and uses portions outside the inner region 208 to contain fluids for effecting buoyancy changes. The variable buoyancy device 200 thus provides a versatile platform that is suitable for many types of missions and applications.

We have recognized that the variable buoyancy device 200 works best for shorter missions, however. For example, the small size of the container 250 may support a limited number of profiling cycles, which may be further limited if

the sonde is expected to descend very deeply. Also, the open bottom **230b** of the outer cavity **210** makes the device **200** susceptible to a positive feedback loop, in which gas **210b** in the outer cavity **210** becomes progressively more compressed as the sonde **110** descends, causing buoyancy to decrease more and more the deeper the sonde goes. Greater and greater amounts of gas may thus be required to stop the descent, or to enable the sonde **110** to rise. In addition, gas **210b** can sometimes escape from the outer cavity **210** unexpectedly, e.g., if the sonde **110** tips over. Further, we have found that the variable buoyancy device **200** may, in some circumstances, consume large amounts of gas just to maintain neutral buoyancy.

FIG. 3 shows an alternative variable buoyancy device **300** which at least in part addresses the above-described issues. The variable buoyancy device **300** may be used as a replacement for the variable buoyancy device **200** in the sonde **110** and may operate in a manner similar to that described above, but with marked improvements in regard to management of gas.

Like the variable buoyancy device **200**, the variable buoyancy device **300** has an inner region **308** surrounded at least in part by an outer cavity **310**. Wall **312** separates the inner region **308** from the outer cavity **310**, and wall **314** forms an outside wall of the outer cavity **310**. The variable buoyancy device **300** also has a closed top **330**, which is both airtight and watertight. Materials may be similar to those described above, with aluminum and/or CPVC being favorable options for use for walls, top, and bottom.

Unlike the variable buoyancy device **200**, the outer cavity **310** of the variable buoyancy device **300** has a closed bottom **340**, which may be both airtight and watertight. Thus, other than by operation of valves (described infra.), the outer cavity **310** forms an enclosed space from which gas and water can neither enter nor escape. Also, the outer cavity **310** has a rigid construction that does not substantially deform as the sonde sinks. The rigid, closed outer cavity **310** thus allows ambient water pressure to have little or no effect on any gas held in the outer cavity **310**. Gas therefore does not tend to compress more and more as the sonde sinks deeper and deeper in the water, and the above-described positive feedback loop is disrupted. For any given combination of water **210a** with gas **210b**, buoyancy of the variable buoyancy device **300** tends to remain constant with changing depth. The closed design also prevents the accidental loss of gas if the sonde tips over.

Also unlike the variable buoyancy device **200**, where the inner region **208** has a closed bottom **230a**, the inner region **308** of the variable buoyancy device **300** preferably has an open bottom **308a**. The open bottom **308a** may be arranged to allow entry of equipment, such as a large tank of compressed gas.

The variable buoyancy device **300** also differs from the device **200** in that it contains a wall **320** that divides the outer cavity **310** into two separate regions, a first region **310a** and a second region **310b**. Each of the regions **310a** and **310b** is separately enclosed and is individually airtight and watertight. Each region **310a** or **310b** can thus contain a respective combination of water with gas, independent of the combination in the other region. In the example shown, the first region **310a** forms a ballast tank and the second region **310b** forms a profile tank.

We have observed that most of the volume of the outer cavity **310** is needed for achieving neutral buoyancy (neither sinking nor rising), whereas a relatively small volume is needed for profiling. This is especially the case for long missions. For example, a large mass of compressed gas is

typically needed to support long missions with many profiling cycles. But a large mass of compressed gas requires a large amount of expelled gas in the outer cavity **310** to achieve neutral buoyancy. The relative sizes of the ballast tank **310a** and the profile tank **310b** reflect this condition, with the ballast tank **310a** typically being larger in volume than the profile tank **310b** (e.g., twice as large, five times as large, ten times as large, etc.). In the example shown, the variable buoyancy device **300** may use the ballast tank **310a** primarily or exclusively for establishing neutral buoyancy and may use the profile tank **310b** primarily or exclusively for profiling.

By closing the outer cavity **310** and separating the ballast tank **310a** from the profile tank **310b**, the variable buoyancy device **300** makes efficient use of gas, which makes the variable buoyancy device **300** especially suitable for long missions involving many profiling cycles, as well as for missions requiring the sonde to descent to great depths.

FIG. 4 shows an example arrangement of valves that may be used with the variable buoyancy device **300** of FIG. 3. As shown, the ballast tank **310a** and the profile tank **310b** are each coupled directly to three valves: one for gas ingress from a container **410**, such as a CO₂ tank; one for gas egress to the environment **202**; and one for egress or ingress of water to and from the environment **202**. The valves may be opened and closed by operation of controller **220**, which may reside in the inner region **308** or elsewhere in the sonde **110**.

For managing the ballast tank **310a**, valves **420a** and **420b** respectively support ingress and egress of gas, and valve **440a** supports ingress and egress of water. To increase buoyancy in the ballast tank **310a**, valves **420a** and **440a** are opened and valve **420b** is closed, causing compressed gas to enter the ballast tank via valve **420a** and an equal volume of water to be forced out into the environment **202**, via valve **440a**. To decrease buoyancy in the ballast tank **310a**, valves **420b** and **440a** are opened and valve **420a** is closed, causing gas to escape the ballast tank **310a** via valve **420b** and an equal volume of water to enter the ballast tank **310a** from the environment **202**, via valve **440a**.

The profile tank **310b** works in a similar way. Valves **430a** and **430b** respectively support ingress and egress of gas, and valve **440b** supports ingress and egress of water. To increase buoyancy, valves **430a** and **440b** are opened and valve **430b** is closed. To decrease buoyancy, valves **430b** and **440b** are opened and valve **430a** is closed.

The ballast tank **310a** and the profile tank **310b** are thus independently controllable, such that each may assume its own combination of water and gas, regardless of that of the other tank. As before, gas may be conducted using tubes and/or manifolds.

FIG. 5 shows an example variable buoyancy device **300** in a more configured state, with FIG. 6 showing example details of a manifold **600** formed within the top piece **330**. In FIG. 5, the container **410** of compressed gas is shown inserted into the inner region **308** via the opening **308a** and extending out a central hole in the bottom piece **340**. The container **410** terminates at the top of the manifold **600**, where gas from the container **410** may flow into the manifold **600**. Valves **420** and **430** (**420a**, **420b**, **430a**, and **430b**) and pressure sensors **510** attach to the top piece **330** of the variable buoyancy device **300**, while valves **440** (**440a** and **440b**) attach to the bottom piece **340**. A small space **540** may be provided between the central hole of the bottom piece **340** and the container **410** to allow for passage of a cable **550**, such as a ribbon cable, which may convey signals and/or

measurements to the controller 220, which may be located in a different module, for example.

The placement of gas-conducting valves 420 and 430 at the top piece 330 allows gas to easily enter and exit at the top, where gas will naturally collect. Likewise, the placement of the water-conducting valves 440 at the bottom piece 340 easily allows water to enter and exit from the bottom. The manifold 600 preferably includes channels (not shown) for conducting gas. A simpler manifold may be formed in the bottom piece 340 and may include channels for conveying water.

To support gas ingress into the outer cavity 310, the manifold 600 includes a receiver 610 that connects to an outlet of the gas container 410 (FIG. 6). Hollow arms 610a and 610b extend from the receiver 610 for allowing compressed gas to conduct from the receiver 610 into the manifold 600. Channels (not shown) within the manifold 600 distribute the gas to valve adapters 620a and 630a, which form airtight seals with respective valves 420a and 430a when the valves are attached. Each valve may have two ports (e.g., input and output), and each valve adapter includes a channel for each port.

In an example, the receiver 610 includes a blade or other protrusion that pierces the opening of the container 410 when the container is inserted, allowing compressed gas to exit the container. The flow of gas from the container 410 is normally blocked when the valves 420a and 430a are closed, but gas selectively flows when one or both of these valves are opened. For example, opening valve 420a causes gas to flow into the ballast tank 310a, via a channel formed within the manifold 600 between the valve adapter 620a and the ballast tank 310a. Such a channel may exit into the ballast tank 310a via an opening in the manifold 600 in a space between the walls 320 and 314 (FIG. 3). Likewise, opening valve 430a causes gas to flow into the profile tank 310b, via a similar channel formed between the valve adapter 630a and the profile tank 310b. Such a channel may exit into the profile tank 310a via an opening in the manifold between the walls 320 and 312.

To support gas egress from the tanks 310a and 310b into the environment 202 and avoid corrosion, valves 420b and 430b are respectively attached, via airtight connections, to valve adapters 620b and 630b. Additional channels connect the valve adapters 620b and 630b to the tanks 310a and 310b, respectively. For example, a channel from valve adapter 620b may open into the ballast tank 310a via an aperture in the manifold between walls 320 and 314, while a channel from valve adapter 630b may open into the profile tank between walls 320 and 312. When either of the valves 420b and 430b is opened, gas from the respective tank flows out through the respective valve and out an aperture 520 into the environment 202.

Although the illustrated apertures 520 are formed within the wall 314, one should note that apertures 520 do not breach the ballast tank 310a. Rather, the top piece 330 may extend partly inside the wall 314, e.g., down to line 332, such that the apertures 520 are disposed above the tank 310a and prevent leakage. In some examples, O-rings are placed between walls 320, 314, and 312 and the top piece 330 to form airtight and watertight seals. A similar arrangement may be used with the bottom piece 340, which can also be seen to extend inside the wall 314, up to line 342.

The manifold in the bottom piece 340 may be similar to the manifold 600 but is simpler, as it need only include two valve adapters for accommodating valves 440a and 440b. A first pair of channels may be formed in the bottom manifold to convey water from the ballast tank 310a to a first port of

the valve 440a, and from a second port of the valve 440a to an aperture 530, which may be similar to the apertures 520. Likewise, a second pair of channels may be formed to convey water from the profile tank 310b to a first port of the valve 440b, and from a second port of the valve 440b to another aperture 530.

As the manifold 600 and the bottom manifold have complex designs, they may be manufactured from multiple parts which are assembled together. Preferably, though, the manifolds or portions thereof are manufactured using new techniques such as 3-D printing.

FIG. 7 shows an example sequence which may be used for assembling the variable buoyancy device 300. Assembly may begin at (A), by attaching the internal wall 312 to the top piece 330. As shown, wall 312 may be realized as a cylinder having a round cross-section. Wall 312 may attach to the top piece 330 via channels formed within an underside of the top piece 330. One or more O-rings may be used at the connection to prevent leaks. O-rings may also be used for attaching each of the additional walls.

At (B), wall 320 is attached to the top piece 330, e.g., in a similar way, with wall 320 surrounding wall 312. Walls 312 and 320 thus form concentric cylinders. An elongated annular space is formed between walls 312 and 320, which will eventually realize the profiling tank 310b.

At (C), outside wall 314 is attached to the top piece 330 and fastened in place, e.g., using screws, rivets, or other fasteners. Wall 314 laterally surrounds wall 320 and forms another concentric cylinder with walls 312 and 320. Another elongated annular space is formed between walls 314 and 320, which will eventually realize the ballast tank 310a.

At (D), the bottom piece 340 is attached, with walls 312, 320, and 314 attaching to the bottom piece 340 as they did to the top piece 330, for example. Completion of the ballast tank 310a and the profile tank 310b is thus achieved. Valves, pressure sensors, and other hardware, as illustrated in FIGS. 5 and 6, may be added to complete the assembly.

FIG. 8 shows an example method 800 that may be carried out in connection with the variable buoyancy device 300. The method 800 is typically performed, for example, by the controller 220 executing software that resides in its memory. The various acts of method 800 may be ordered in any suitable way.

At 810, the controller 220 operates the valves to set neutral buoyancy of the sonde 110 using the ballast tank 310a. To this end, the controller may configure the valves to start filling the ballast tank 310a with water. For example, controller 220 opens valves 420b and 440a in timed increments until the sonde 110 just begins to sink. At this point, the sonde 110 has achieved neutral buoyancy. Owing to the closed, rigid design of the variable buoyancy device 300, the sonde 110 substantially maintains this neutral buoyancy independent of depth.

At 820, the controller 220 begins performing profiling cycles by modulating the contents of the profile tank 310b. For example, the controller 220 directs the variable buoyancy device 300 to decrease buoyancy by opening valves 430b and 440b, e.g., in a pulsed manner, causing the sonde 110 to sink. Once the desired depth is achieved, the controller 220 may open valves 430a and 440b (with valve 430b closed), causing some volume of water to be displaced with gas and increasing the buoyancy of the sonde 110. Depending on the amount of water displaced, the sonde 110 may slow its descent, stop descending, or begin to ascend. The controller 220 may use pulsed increments to vary buoyancy

of the profile tank **310b**. Each time the sonde surfaces, the sonde may transmit measurements to a base station, if desired.

The controller **220** may continue in this fashion to achieve a specified number of profiling cycles. If it is desired to wait between successive cycles, the controller **220** may direct the variable buoyancy device **300** to sink the sonde **110** to depths at which sunlight is unable to reach. At such depths, biofouling is minimized and optimal operation of the sonde **110** is likely to be preserved.

At **830**, the controller **220** may periodically adjust the ballast tank **310a** to reestablish neutral buoyancy. For example, as profiling proceeds some mass of gas is typically released into the environment **202**, causing the container **410** to become lighter and thus the sonde **110** to become more buoyant. Adjustments of the ballast tank **310a** may therefore be needed to compensate for the changes in buoyancy consequent to profiling. Adjustments to the ballast tank **310a** may also be desirable for other reasons, such as when the salinity and/or temperature of water in the environment **202** around the sonde **110** changes significantly.

At **840**, once the specified number of profiling cycles has been achieved and the mission is complete, the controller **220** may direct the variable buoyancy device **300** to scuttle the sonde **110**, e.g., by opening all of the valves **420**, **430**, and **440** and allowing all the gas to escape. As an alternative to scuttling, the controller **220** may instead direct the sonde **110** to surface, such that the sonde **110** may be retrieved and possibly reused.

FIG. **9** shows an example method **900** of changing the buoyancy of a device. The method **900** may be carried out in connection with the sonde **110** and provides a high-level summary of some of the features described above. Also, the method **900** may be performed with either of the variable buoyancy modules **200** or **300**. The various acts of method **900** may be ordered in any suitable way.

At **910**, a device, such as sonde **110** having a variable buoyancy module, is deployed in a body of water **202**. The device has (i) an inner region **208** or **308** configured to at least partially contain equipment (such as container **250** or **410**, controller **220**, and so forth) and (ii) an outer cavity **210** or **310** that extends at least partially around the inner region and is separated from the inner region by a set of walls, such as wall **212** or **312**.

At **920**, a set of valves is activated to establish a first combination in the outer cavity **210** or **310** of a first fluid **210a** and a second fluid **210b**. The first combination provides the device with a first buoyancy condition that brings the device **110** to a first level **950** within the body of water **202**, the first fluid **210a** and the second fluid **210b** having different buoyancies.

At **930**, after the device **110** has operated with the first buoyancy condition for a period of time, the set of valves is reactivated to establish a second combination in the outer cavity **210** or **310** of the first fluid and the second fluid. The second combination provides the device **110** with a second buoyancy condition that brings the device to a second level **960**, different from the first level **950**, within the body of water **202**.

Improved techniques have been described that involve a variable buoyancy device **200** or **300** having an inner region **208** or **308** and an outer cavity **210** or **310**. The outer cavity **210** or **310** extends at least partially around the inner region and is adapted to contain fluids **210a** and **210b**, such as a liquid and a gas, the relative proportions of which can be varied to vary buoyancy. The inner region provides an advantageous location for housing equipment, while the

outer cavity provides a significant volume for achieving a wide range of buoyancy adjustments. The improved techniques enable the variable buoyancy device **200** or **300** to have a non-intrusive form factor (e.g., a slim or streamline body) with gas and/or liquid held efficiently in the outer cavity outside the inner region.

Having described certain embodiments, numerous alternative embodiments or variations can be made. For example, disclosed embodiments use combinations of ambient water and CO₂ to establish different levels of buoyancy. The invention is not limited to these fluids, however. Also, embodiments have been disclosed in connection with a sonde **110**. Other embodiments may employ the disclosed variable buoyancy devices with other equipment, however, such as submersible buoys, vehicles, probes, and the like. In some examples, a source of gas may take forms other than a container **250** or **410** of compressed gas. For example, gas may be created on demand, e.g., via a chemical reaction caused by exposing a substrate, such as one containing aluminum, to water.

Further, although features have been shown and described with reference to particular embodiments hereof, such features may be included and hereby are included in any of the disclosed embodiments and their variants. Thus, it is understood that features disclosed in connection with any embodiment are included in any other embodiment.

Further still, the improvement or portions thereof may be embodied as a computer program product including one or more non-transient, computer-readable storage media, such as a magnetic disk, magnetic tape, compact disk, DVD, optical disk, flash drive, solid state drive, SD (Secure Digital) chip or device, Application Specific Integrated Circuit (ASIC), Field Programmable Gate Array (FPGA), and/or the like (shown by way of example as medium **850** in FIG. **8**). Any number of computer-readable media may be used. The media may be encoded with instructions which, when executed on one or more computers or other processors, perform the process or processes described herein. Such media may be considered articles of manufacture or machines, and may be transportable from one machine to another.

As used throughout this document, the words “comprising,” “including,” “containing,” and “having” are intended to set forth certain items, steps, elements, or aspects of something in an open-ended fashion. Also, as used herein and unless a specific statement is made to the contrary, the word “set” means one or more of something. This is the case regardless of whether the phrase “set of” is followed by a singular or plural object and regardless of whether it is conjugated with a singular or plural verb. Also, a “set of” elements can describe fewer than all elements present. Thus, there may be additional elements of the same kind that are not part of the set. Further, ordinal expressions, such as “first,” “second,” “third,” and so on, may be used as adjectives herein for identification purposes. Unless specifically indicated, these ordinal expressions are not intended to imply any ordering or sequence. Thus, for example, a “second” event may take place before or after a “first event,” or even if no first event ever occurs. In addition, an identification herein of a particular element, feature, or act as being a “first” such element, feature, or act should not be construed as requiring that there must also be a “second” or other such element, feature or act. Rather, the “first” item may be the only one. Also, and unless specifically stated to the contrary, “based on” is intended to be nonexclusive. Thus, “based on” should not be interpreted as meaning “based exclusively on” but rather “based at least in part on”

13

unless specifically indicated otherwise. Although certain embodiments are disclosed herein, it is understood that these are provided by way of example only and should not be construed as limiting.

Those skilled in the art will therefore understand that various changes in form and detail may be made to the embodiments disclosed herein without departing from the scope of the following claims.

What is claimed is:

1. A variable buoyancy device, comprising:
 - an inner region configured to at least partially contain equipment;
 - an outer cavity that extends completely around the inner region and is separated from the inner region by a set of walls;
 - a set of valves; and
 - a controller coupled to the set of valves, the controller constructed and arranged to:
 - activate the set of valves to establish a first combination of a first fluid and a second fluid in the outer cavity, the first combination providing the device with a first buoyancy condition; and
 - reactivate the set of valves to establish a second combination of the first fluid and the second fluid in the outer cavity, the second combination providing the device with a second buoyancy condition, the first fluid and the second fluid having different buoyancies.
2. The variable buoyancy device of claim 1, wherein the set of valves includes:
 - a first valve coupled between the outer cavity and an environment of the device, the first fluid obtained from the environment of the device; and
 - a second valve coupled between the outer cavity and a source of the second fluid.
3. The variable buoyancy device of claim 2, wherein the first fluid comprises a liquid and the second fluid comprises a gas.
4. The variable buoyancy device of claim 3, wherein the source of the second fluid includes a container of compressed gas.
5. The variable buoyancy device of claim 3, wherein the outer cavity extends at least partially along the device lengthwise.
6. The variable buoyancy device of claim 5, wherein the outer cavity has a closed top and an open bottom open to the environment of the device.
7. The variable buoyancy device of claim 5, wherein the outer cavity includes a first region and a second region that provide respective enclosed spaces, the first region and the second region configured to contain respective combinations of the first fluid and the second fluid.
8. The variable buoyancy device of claim 7, wherein the set of valves is configured to independently control the respective combinations in the first region and the second region.
9. The variable buoyancy device of claim 8, wherein the first region is external to the second region and is larger in volume than the second region.
10. The variable buoyancy device of claim 7, wherein the outer cavity has an annular cross-section over at least a portion of its length, and wherein the first region and the second region are separated at least in part by a cylindrical wall within the outer cavity.
11. The variable buoyancy device of claim 7, wherein the source of the second fluid includes a container of com-

14

pressed gas, the container at least partially disposed in the inner region as equipment of the device.

12. A sonde, comprising multiple modules arranged end-to-end, the modules including a variable buoyancy module, the variable buoyancy module including:

- an inner region configured to at least partially contain equipment;
- an outer cavity that extends completely around the inner region and is separated from the inner region by a set of walls;
- a set of valves; and
- a controller coupled to the set of valves, the controller constructed and arranged to:
 - activate the set of valves to establish a first combination of a first fluid and a second fluid in the outer cavity, the first combination providing the sonde with a first buoyancy condition; and
 - reactivate the set of valves to establish a second combination of the first fluid and the second fluid in the outer cavity, the second combination providing the sonde with a second buoyancy condition, the first fluid and the second fluid having different buoyancies.

13. A method of changing buoyancy of a device, the method comprising:

- deploying the device in a body of water, the device having (i) an inner region configured to at least partially contain equipment and (ii) an outer cavity that extends completely around the inner region and is separated from the inner region by a set of walls;
- activating a set of valves to establish a first combination in the outer cavity of a first fluid and a second fluid, the first combination providing the device with a first buoyancy condition that brings the device to a first level within the body of water, the first fluid and the second fluid having different buoyancies; and
- after the device has operated with the first buoyancy condition for a period of time, reactivating the set of valves to establish a second combination in the outer cavity of the first fluid and the second fluid, the second combination providing the device with a second buoyancy condition that brings the device to a second level, different from the first level, within the body of water.

14. The method of claim 13, wherein the first fluid is water provided from the body of water, wherein activating the set of valves causes a volume of water from the body of water to enter the outer cavity, wherein the second fluid is gas provided from a container of compressed gas, and wherein reactivating the set of valves causes a quantity of gas from the container to enter the outer cavity and a quantity of water to be displaced from the outer cavity.

15. The method of claim 14, wherein the outer cavity includes first and second regions that provide respective enclosed spaces, and wherein the method further comprises: establishing a ballast setting of the device by providing a set combination of water and gas in the first region of the outer cavity; and varying a depth of the device in the body of the water by varying a combination of water and gas in the second region of the outer cavity while maintaining constant the set combination of water and gas in the first region.

16. The method of claim 15, wherein providing the set combination includes establishing neutral buoyancy of the device in the body of water.

15

17. The method of claim 16, wherein providing the set combination includes introducing water into the first region by:

- opening a first valve coupled between the first region and the body of water; and
- opening a second valve coupled between an upper portion of the first region and the body of water.

18. The method of claim 15, wherein establishing the ballast setting of the device includes introducing gas into the first region by:

- opening a first valve coupled between the first region and the body of water; and
- opening a third valve coupled between the first region and the container of compressed gas.

19. The method of claim 15, wherein varying the depth of the device further includes increasing the buoyancy of the device by:

16

opening a fourth valve coupled between a lower portion of the second region and the body of water; and opening a fifth valve coupled between the second region and the container of compressed gas,

5 wherein opening the fourth valve and the fifth valve displaces a volume of water in the second region with a volume of gas.

20. The method of claim 19, wherein varying the depth of the device includes decreasing the buoyancy of the device

10 by:
opening the fourth valve; and
opening a sixth valve coupled between the second region and the body of water,
wherein opening the fourth valve and the sixth valve displaces a volume of gas in the second region with a volume of water.

* * * * *