



US009220302B2

(12) **United States Patent**
DePiano et al.

(10) **Patent No.:** **US 9,220,302 B2**
(45) **Date of Patent:** **Dec. 29, 2015**

(54) **CARTRIDGE FOR AN AEROSOL DELIVERY DEVICE AND METHOD FOR ASSEMBLING A CARTRIDGE FOR A SMOKING ARTICLE**

(58) **Field of Classification Search**
CPC A24F 47/008
USPC 392/386, 394-395
See application file for complete search history.

(71) Applicant: **R.J. Reynolds Tobacco Company**,
Winston-Salem, NC (US)

(72) Inventors: **John DePiano**, Burlington, MA (US);
David Smith, Needham, MA (US);
Charles Jacob Novak, III,
Winston-Salem, NC (US); **Frank S. Silveira**,
Wilmington, MA (US); **Steven Lee Alderman**,
Lewisville, NC (US); **Grady Lance Dooly**,
Winston-Salem, NC (US); **Frederic Philippe Ampolini**,
Winston-Salem, NC (US); **Timothy Brian Nestor**,
Advance, NC (US); **Quentin Paul Guenther, Jr.**,
Winston-Salem, NC (US); **Stephen Benson Sears**,
Siler City, NC (US); **John William Wolber**,
Nashua, NH (US); **Michael Laine**,
Newburyport, MA (US)

(56) **References Cited**

U.S. PATENT DOCUMENTS

1,771,366 A 7/1930 Wyss et al.
2,057,353 A 10/1936 Whittemore, Jr.

(Continued)

FOREIGN PATENT DOCUMENTS

AU 276250 7/1965
CA 2 752 255 8/2010

(Continued)

OTHER PUBLICATIONS

Invitation to Pay Additional Fees and Partial International Search for corresponding International Application No. PCT/US2014/024697 mailed Sep. 23, 2014.

(Continued)

Primary Examiner — Richard Crispino

Assistant Examiner — Eric Yaary

(74) *Attorney, Agent, or Firm* — Womble Carlyle Sandridge & Rice LLP

(73) Assignee: **R.J. Reynolds Tobacco Company**,
Winston-Salem, NC (US)

(*) Notice: Subject to any disclaimer, the term of this patent is extended or adjusted under 35 U.S.C. 154(b) by 445 days.

(21) Appl. No.: **13/841,233**

(22) Filed: **Mar. 15, 2013**

(65) **Prior Publication Data**

US 2014/0261408 A1 Sep. 18, 2014

(51) **Int. Cl.**
A24F 47/00 (2006.01)

(52) **U.S. Cl.**
CPC **A24F 47/008** (2013.01); **Y10T 29/49002**
(2015.01); **Y10T 29/49826** (2015.01)

(57) **ABSTRACT**

The present disclosure relates to a cartridge for an aerosol delivery device such as a smoking article. The cartridge may include a base, a reservoir substrate, and an atomizer. The reservoir substrate may define a cavity therethrough. The atomizer may comprise a liquid transport element and a heating element extending at least partially about the liquid transport element. The atomizer may extend through the cavity through the reservoir substrate such that the heating element is positioned proximate an end of the reservoir substrate. Ends of the liquid transport element may extend to an opposing end of the reservoir substrate. A related method for assembling a cartridge for a smoking article is also provided.

20 Claims, 28 Drawing Sheets

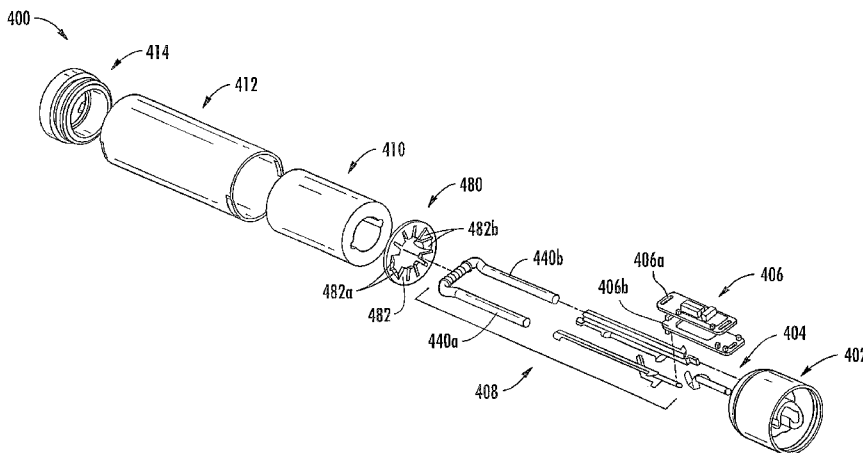

(56)

References Cited

U.S. PATENT DOCUMENTS

2,104,266 A	1/1938	McCormick	5,131,415 A	7/1992	Munoz et al.
2,805,669 A	9/1957	Meriro	5,143,097 A	9/1992	Sohn et al.
3,200,819 A	4/1965	Gilbert	5,144,962 A	9/1992	Counts et al.
3,316,919 A	5/1967	Green et al.	5,146,934 A	9/1992	Deevi et al.
3,398,754 A	8/1968	Tughan	5,159,940 A	11/1992	Hayward et al.
3,419,015 A	12/1968	Wochnowski	5,159,942 A	11/1992	Brinkley et al.
3,424,171 A	1/1969	Rooker	5,179,966 A	1/1993	Losee et al.
3,476,118 A	11/1969	Luttich	5,211,684 A	5/1993	Shannon et al.
4,054,145 A	10/1977	Berndt et al.	5,220,930 A	6/1993	Gentry
4,131,117 A	12/1978	Kite et al.	5,224,498 A	7/1993	Deevi et al.
4,150,677 A	4/1979	Osborne	5,228,460 A	7/1993	Sprinkel, Jr. et al.
4,190,046 A	2/1980	Virag	5,230,354 A	7/1993	Smith et al.
4,219,032 A	8/1980	Tabatznik et al.	5,235,992 A	8/1993	Sensabaugh
4,259,970 A	4/1981	Green, Jr.	5,243,999 A	9/1993	Smith
4,284,089 A	8/1981	Ray	5,246,018 A	9/1993	Deevi et al.
4,303,083 A	12/1981	Burruss, Jr.	5,249,586 A	10/1993	Morgan et al.
4,449,541 A	5/1984	Mays et al.	5,261,424 A	11/1993	Sprinkel, Jr.
4,506,682 A	3/1985	Muller	5,269,327 A	12/1993	Counts et al.
4,635,651 A	1/1987	Jacobs	5,285,798 A	2/1994	Banerjee et al.
4,674,519 A	6/1987	Keritsis et al.	5,293,883 A	3/1994	Edwards
4,708,151 A	11/1987	Shelar	5,301,694 A	4/1994	Raymond
4,714,082 A	12/1987	Banerjee et al.	5,303,720 A	4/1994	Banerjee et al.
4,735,217 A	4/1988	Gerth et al.	5,318,050 A	6/1994	Gonzalez-Parra et al.
4,756,318 A	7/1988	Clearman et al.	5,322,075 A	6/1994	Deevi et al.
4,771,795 A	9/1988	White et al.	5,322,076 A	6/1994	Brinkley et al.
4,776,353 A	10/1988	Lilja et al.	5,339,838 A	8/1994	Young et al.
4,793,365 A	12/1988	Sensabaugh, Jr. et al.	5,345,951 A	9/1994	Serrano et al.
4,800,903 A	1/1989	Ray et al.	5,353,813 A	10/1994	Deevi et al.
4,819,665 A	4/1989	Roberts et al.	5,357,984 A	10/1994	Farrier et al.
4,821,749 A	4/1989	Toft et al.	5,360,023 A	11/1994	Blakley et al.
4,830,028 A	5/1989	Lawson et al.	5,369,723 A	11/1994	Counts et al.
4,836,224 A	6/1989	Lawson et al.	5,372,148 A	12/1994	McCafferty et al.
4,836,225 A	6/1989	Sudoh	5,377,698 A	1/1995	Litzinger et al.
4,848,374 A	7/1989	Chard et al.	5,388,574 A	2/1995	Ingebretsen et al.
4,848,376 A	7/1989	Lilja et al.	5,388,594 A	2/1995	Counts et al.
4,874,000 A	10/1989	Tamol et al.	5,408,574 A	4/1995	Deevi et al.
4,880,018 A	11/1989	Graves, Jr. et al.	5,435,325 A	7/1995	Clapp et al.
4,887,619 A	12/1989	Burcham, Jr. et al.	5,445,169 A	8/1995	Brinkley et al.
4,907,606 A	3/1990	Lilja et al.	5,468,266 A	11/1995	Bensalem et al.
4,913,168 A	4/1990	Potter et al.	5,468,936 A	11/1995	Deevi et al.
4,917,119 A	4/1990	Potter et al.	5,479,948 A	1/1996	Counts et al.
4,917,128 A	4/1990	Clearman et al.	5,498,850 A	3/1996	Das
4,922,901 A	5/1990	Brooks et al.	5,498,855 A	3/1996	Deevi et al.
4,924,888 A	5/1990	Perfetti et al.	5,499,636 A	3/1996	Baggett, Jr. et al.
4,928,714 A	5/1990	Shannon	5,501,237 A	3/1996	Young et al.
4,938,236 A	7/1990	Banerjee et al.	5,505,214 A	4/1996	Collins et al.
4,941,483 A	7/1990	Ridings et al.	5,515,842 A	5/1996	Ramseyer et al.
4,941,484 A	7/1990	Clapp et al.	5,530,225 A	6/1996	Hajaligol
4,945,931 A	8/1990	Gori	5,551,450 A	9/1996	Hemsley
4,947,874 A	8/1990	Brooks et al.	5,551,451 A	9/1996	Riggs et al.
4,947,875 A	8/1990	Brooks et al.	5,564,442 A	10/1996	MacDonald et al.
4,972,854 A	11/1990	Kiernan et al.	5,573,692 A	11/1996	Das et al.
4,972,855 A	11/1990	Kuriyama et al.	5,591,368 A	1/1997	Fleischhauer et al.
4,986,286 A	1/1991	Roberts et al.	5,593,792 A	1/1997	Farrier et al.
4,987,906 A	1/1991	Young et al.	5,595,577 A	1/1997	Bensalem et al.
5,005,593 A	4/1991	Fagg	5,595,706 A	1/1997	Sikka et al.
5,019,122 A	5/1991	Clearman et al.	5,611,360 A	3/1997	Tang
5,022,416 A	6/1991	Watson	5,613,504 A	3/1997	Collins et al.
5,034,721 A	7/1991	Benedictus	5,613,505 A	3/1997	Campbell et al.
5,042,510 A	8/1991	Curtiss et al.	5,649,552 A	7/1997	Cho et al.
5,056,537 A	10/1991	Brown et al.	5,649,554 A	7/1997	Sprinkel et al.
5,060,669 A	10/1991	White et al.	5,659,656 A	8/1997	Das
5,060,671 A	10/1991	Counts et al.	5,665,262 A	9/1997	Hajaligol et al.
5,065,775 A	11/1991	Fagg	5,666,976 A	9/1997	Adams et al.
5,072,744 A	12/1991	Luke et al.	5,666,977 A	9/1997	Higgins et al.
5,074,319 A	12/1991	White et al.	5,666,978 A	9/1997	Counts et al.
5,076,296 A	12/1991	Nystrom et al.	5,692,525 A	12/1997	Counts et al.
5,093,894 A	3/1992	Deevi et al.	5,692,526 A	12/1997	Adams et al.
5,095,921 A	3/1992	Losee et al.	5,708,258 A	1/1998	Counts et al.
5,097,850 A	3/1992	Braunshteyn et al.	5,711,320 A	1/1998	Martin
5,099,862 A	3/1992	White et al.	5,726,421 A	3/1998	Fleischhauer et al.
5,099,864 A	3/1992	Young et al.	5,727,571 A	3/1998	Meiring et al.
5,103,842 A	4/1992	Strang et al.	5,730,158 A	3/1998	Collins et al.
5,121,757 A	6/1992	White et al.	5,750,964 A	5/1998	Counts et al.
5,129,409 A	7/1992	White et al.	5,799,663 A	9/1998	Gross et al.
			5,816,263 A	10/1998	Counts et al.
			5,819,756 A	10/1998	Mielordt
			5,829,453 A	11/1998	White et al.
			5,865,185 A	2/1999	Collins et al.

(56)

References Cited

U.S. PATENT DOCUMENTS

5,865,186 A	2/1999	Volsey, II	2004/0020500 A1	2/2004	Wrenn et al.
5,878,752 A	3/1999	Adams et al.	2004/0129280 A1	7/2004	Woodson et al.
5,880,439 A	3/1999	Deevi et al.	2004/0149296 A1	8/2004	Rostami et al.
5,915,387 A	6/1999	Baggett, Jr. et al.	2004/0200488 A1	10/2004	Felter et al.
5,934,289 A	8/1999	Watkins et al.	2004/0226568 A1	11/2004	Takeuchi et al.
5,954,979 A	9/1999	Counts et al.	2004/0255965 A1	12/2004	Perfetti et al.
5,967,148 A	10/1999	Harris et al.	2005/0016549 A1	1/2005	Banerjee et al.
6,026,820 A	2/2000	Baggett, Jr. et al.	2005/0066986 A1	3/2005	Nestor et al.
6,033,623 A	3/2000	Deevi et al.	2005/0172976 A1	8/2005	Newman et al.
6,040,560 A	3/2000	Fleischhauer et al.	2005/0274390 A1	12/2005	Banerjee et al.
6,053,176 A	4/2000	Adams et al.	2006/0016453 A1	1/2006	Kim
6,089,857 A	7/2000	Matsuura et al.	2006/0070633 A1	4/2006	Rostami et al.
6,095,153 A	8/2000	Kessler et al.	2006/0162733 A1	7/2006	McGrath et al.
6,116,247 A	9/2000	Banyasz et al.	2006/0185687 A1	8/2006	Hearn et al.
6,119,700 A	9/2000	Fleischhauer et al.	2006/0196518 A1	9/2006	Hon
6,125,853 A	10/2000	Susa et al.	2007/0074734 A1	4/2007	Braunshsteyn et al.
6,125,855 A	10/2000	Nevett et al.	2007/0102013 A1	5/2007	Adams et al.
6,125,866 A	10/2000	Nichols et al.	2007/0215167 A1	9/2007	Crooks et al.
6,155,268 A	12/2000	Takeuchi	2007/0283972 A1	12/2007	Monsees et al.
6,164,287 A	12/2000	White	2008/0092912 A1	4/2008	Robinson et al.
6,182,670 B1	2/2001	White	2008/0149118 A1	6/2008	Oglesby et al.
6,196,218 B1	3/2001	Voges	2008/0245377 A1	10/2008	Marshall et al.
6,196,219 B1	3/2001	Hess et al.	2008/0257367 A1	10/2008	Paterno et al.
6,216,706 B1	4/2001	Kumar et al.	2008/0276947 A1	11/2008	Martzel
6,289,898 B1	9/2001	Fournier et al.	2008/0302374 A1	12/2008	Wengert et al.
6,349,728 B1	2/2002	Pham	2009/0065010 A1	3/2009	Shands
6,357,671 B1	3/2002	Cewers	2009/0095311 A1	4/2009	Hon
6,418,938 B1	7/2002	Fleischhauer et al.	2009/0095312 A1	4/2009	Herbrich et al.
6,446,426 B1	9/2002	Sweeney et al.	2009/0126745 A1	5/2009	Hon
6,532,965 B1	3/2003	Abhulimen et al.	2009/0188490 A1	7/2009	Hon
6,598,607 B2	7/2003	Adiga et al.	2009/0230117 A1	9/2009	Fernando et al.
6,601,776 B1	8/2003	Oljaca et al.	2009/0260641 A1	10/2009	Monsees et al.
6,615,840 B1	9/2003	Fournier et al.	2009/0260642 A1	10/2009	Monsees et al.
6,688,313 B2	2/2004	Wrenn et al.	2009/0272379 A1	11/2009	Thorens et al.
6,701,936 B2	3/2004	Shafer et al.	2009/0283103 A1	11/2009	Nielsen et al.
6,715,494 B1	4/2004	McCoy	2009/0293892 A1	12/2009	Williams et al.
6,730,832 B1	5/2004	Dominguez et al.	2009/0320863 A1	12/2009	Fernando et al.
6,772,756 B2	8/2004	Shayan	2009/0324206 A1	12/2009	Young et al.
6,803,545 B2	10/2004	Blake et al.	2010/0006113 A1	1/2010	Urtsev et al.
6,803,550 B2	10/2004	Sharpe et al.	2010/0024834 A1	2/2010	Oglesby et al.
6,810,883 B2	11/2004	Felter et al.	2010/0043809 A1	2/2010	Magnon
6,854,461 B2	2/2005	Nichols	2010/0059070 A1	3/2010	Potter et al.
6,854,470 B1	2/2005	Pu	2010/0059073 A1	3/2010	Hoffmann et al.
6,994,096 B2	2/2006	Rostami et al.	2010/0065075 A1	3/2010	Banerjee et al.
7,011,096 B2	3/2006	Li et al.	2010/0083959 A1	4/2010	Siller
7,017,585 B2	3/2006	Li et al.	2010/0163063 A1	7/2010	Fernando et al.
7,025,066 B2	4/2006	Lawson et al.	2010/0200006 A1	8/2010	Robinson et al.
7,117,867 B2	10/2006	Cox et al.	2010/0229881 A1	9/2010	Hearn
7,163,015 B2	1/2007	Moffitt	2010/0242974 A1	9/2010	Pan
7,173,222 B2	2/2007	Cox et al.	2010/0242976 A1	9/2010	Katayama et al.
7,185,659 B2	3/2007	Sharpe et al.	2010/0258139 A1	10/2010	Onishi et al.
7,234,470 B2	6/2007	Yang	2010/0300467 A1	12/2010	Kuistilla et al.
7,290,549 B2	11/2007	Banerjee et al.	2010/0307518 A1	12/2010	Wang
7,293,565 B2	11/2007	Griffin et al.	2010/0313901 A1	12/2010	Fernando et al.
7,392,809 B2	7/2008	Larson et al.	2011/0005535 A1	1/2011	Xiu
7,513,253 B2	4/2009	Kobayashi et al.	2011/0011396 A1	1/2011	Fang
7,647,932 B2	1/2010	Cantrell et al.	2011/0036363 A1	2/2011	Urtsev et al.
7,690,385 B2	4/2010	Moffitt	2011/0036365 A1	2/2011	Chong et al.
7,692,123 B2	4/2010	Baba et al.	2011/0073121 A1	3/2011	Levin et al.
7,726,320 B2	6/2010	Robinson et al.	2011/0088707 A1	4/2011	Hajaligol
7,775,459 B2	8/2010	Martens, III et al.	2011/0094523 A1	4/2011	Thorens et al.
7,810,505 B2	10/2010	Yang	2011/0120482 A1	5/2011	Brenneise
7,832,410 B2	11/2010	Hon	2011/0126848 A1	6/2011	Zuber et al.
7,845,359 B2	12/2010	Montaser	2011/0155153 A1	6/2011	Thorens et al.
7,878,209 B2	2/2011	Newbery et al.	2011/0155718 A1	6/2011	Greim et al.
7,896,006 B2	3/2011	Hamano et al.	2011/0162663 A1	7/2011	Bryman
8,066,010 B2	11/2011	Newbery et al.	2011/0168194 A1	7/2011	Hon
8,079,371 B2	12/2011	Robinson et al.	2011/0180082 A1	7/2011	Banerjee et al.
8,127,772 B2	3/2012	Montaser	2011/0265806 A1	11/2011	Alarcon et al.
8,156,944 B2	4/2012	Han	2011/0303231 A1	12/2011	Li et al.
8,365,742 B2	2/2013	Hon	2011/0309157 A1	12/2011	Yang et al.
8,375,957 B2	2/2013	Hon	2012/0042885 A1	2/2012	Stone et al.
8,393,331 B2	3/2013	Hon	2012/0060853 A1	3/2012	Robinson et al.
2002/0146242 A1	10/2002	Vieira	2012/0111347 A1	5/2012	Hon
2003/0131859 A1	7/2003	Li et al.	2012/0260927 A1	10/2012	Liu
			2012/0279512 A1	11/2012	Hon
			2013/0037041 A1	2/2013	Worm et al.
			2014/0048086 A1	2/2014	Zhanghua

(56)

References Cited

U.S. PATENT DOCUMENTS

FOREIGN PATENT DOCUMENTS

CN	1541577	11/2004
CN	2719043	8/2005
CN	200997909	1/2008
CN	101116542	2/2008
CN	101176805	5/2008
CN	201379072	1/2010
CN	202 750 708	2/2013
DE	102006041042	3/2008
EP	0 295 122	12/1988
EP	0 430 566	6/1991
EP	0 845 220	6/1998
EP	1 618 803	1/2006
EP	1 996 037	4/2012
EP	2 468 116	6/2012
EP	1 993 388	8/2012
EP	2 754 359	7/2014
GB	1444461	7/1976
GB	2469850	11/2010
WO	WO 86/02528	5/1986
WO	WO 97/48293	12/1997
WO	WO 02/37990	5/2002
WO	WO 03/034847 A1	5/2003
WO	WO 2004/043175	5/2004
WO	WO 2007/131449	11/2007
WO	WO 2009/105919	9/2009
WO	WO 2009/155734	12/2009
WO	WO 2010/003480	1/2010

WO	WO 2010/045670	4/2010
WO	WO 2010/073122	7/2010
WO	WO 2010/091593	8/2010
WO	WO 2010/118644	10/2010
WO	WO 2010/140937	12/2010
WO	WO 2011/010334	1/2011
WO	WO 2011/081558	7/2011
WO	WO 2012/072762	6/2012
WO	WO 2013/089551	6/2013
WO	WO 2014/088889	6/2014

OTHER PUBLICATIONS

U.S. Appl. No. 29/432,110, filed Sep. 13, 2012, Potter.
 U.S. Appl. No. 13/432,406, filed Mar. 28, 2012, Griffith, Jr.
 U.S. Appl. No. 13/536,438, filed Jun. 28, 2012, Sebastian.
 U.S. Appl. No. 13/602,871, filed Sep. 4, 2012, Collett.
 U.S. Appl. No. 13/603,612, filed Sep. 5, 2012, Chang.
 U.S. Appl. No. 13/647,000, filed Oct. 8, 2012, Sears.
 U.S. Appl. No. 13/708,381, filed Dec. 7, 2012, Ward.
 U.S. Appl. No. 13/754,324, filed Jan. 30, 2013, Sears.
 U.S. Appl. No. 13/788,455, filed Mar. 7, 2013, Novak, III.
 U.S. Appl. No. 13/796,725, filed Mar. 12, 2013, Potter.
 U.S. Appl. No. 13/802,950, filed Mar. 14, 2013, Chapman.
 U.S. Appl. No. 13/826,929, filed Mar. 14, 2013, Ampolini.
 U.S. Appl. No. 13/827,994, filed Mar. 14, 2013, DePiano.
 U.S. Appl. No. 13/837,542, filed Mar. 15, 2013, Ampolini.
 U.S. Appl. No. 13/840,264, filed Mar. 15, 2013, Novak, III.
 U.S. Appl. No. 13/842,125, filed Mar. 15, 2013, DePiano.
 International Search Report and Written Opinion of the International
 Searching Authority for corresponding International Application No.
 PCT/US2014/024697 mailed Jan. 20, 2015.

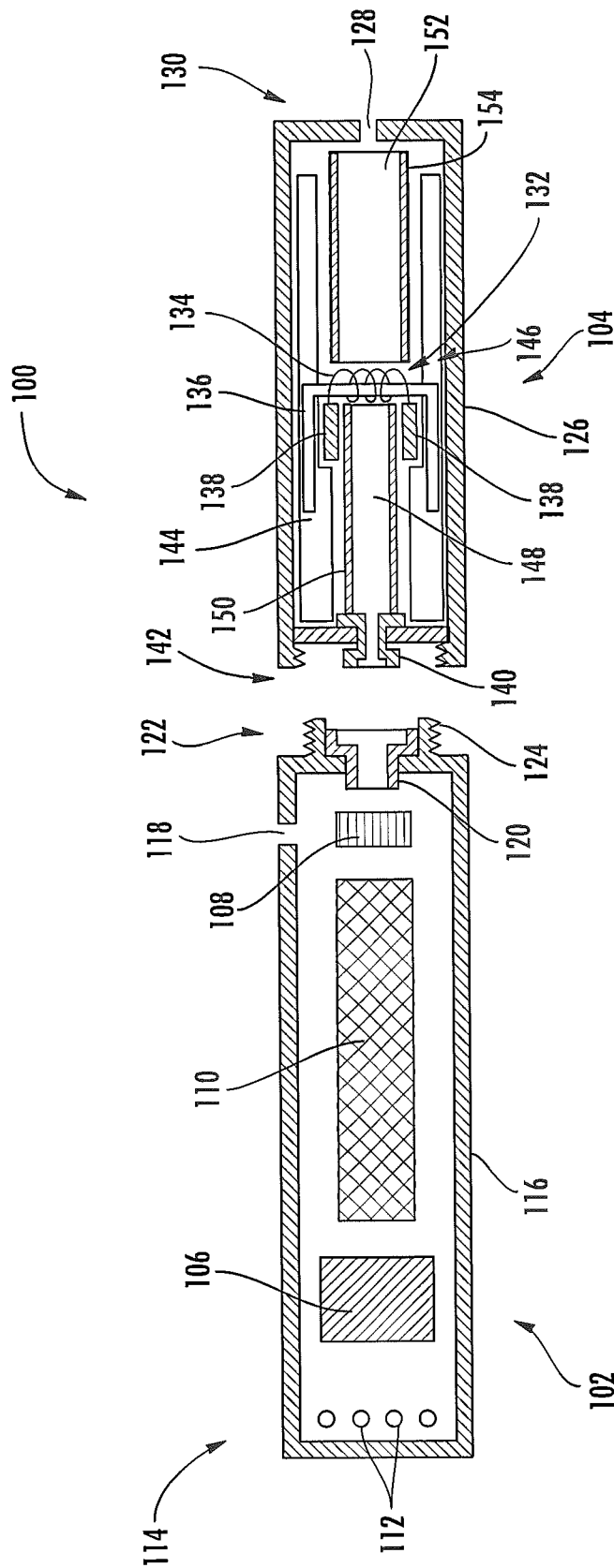

FIG. 1

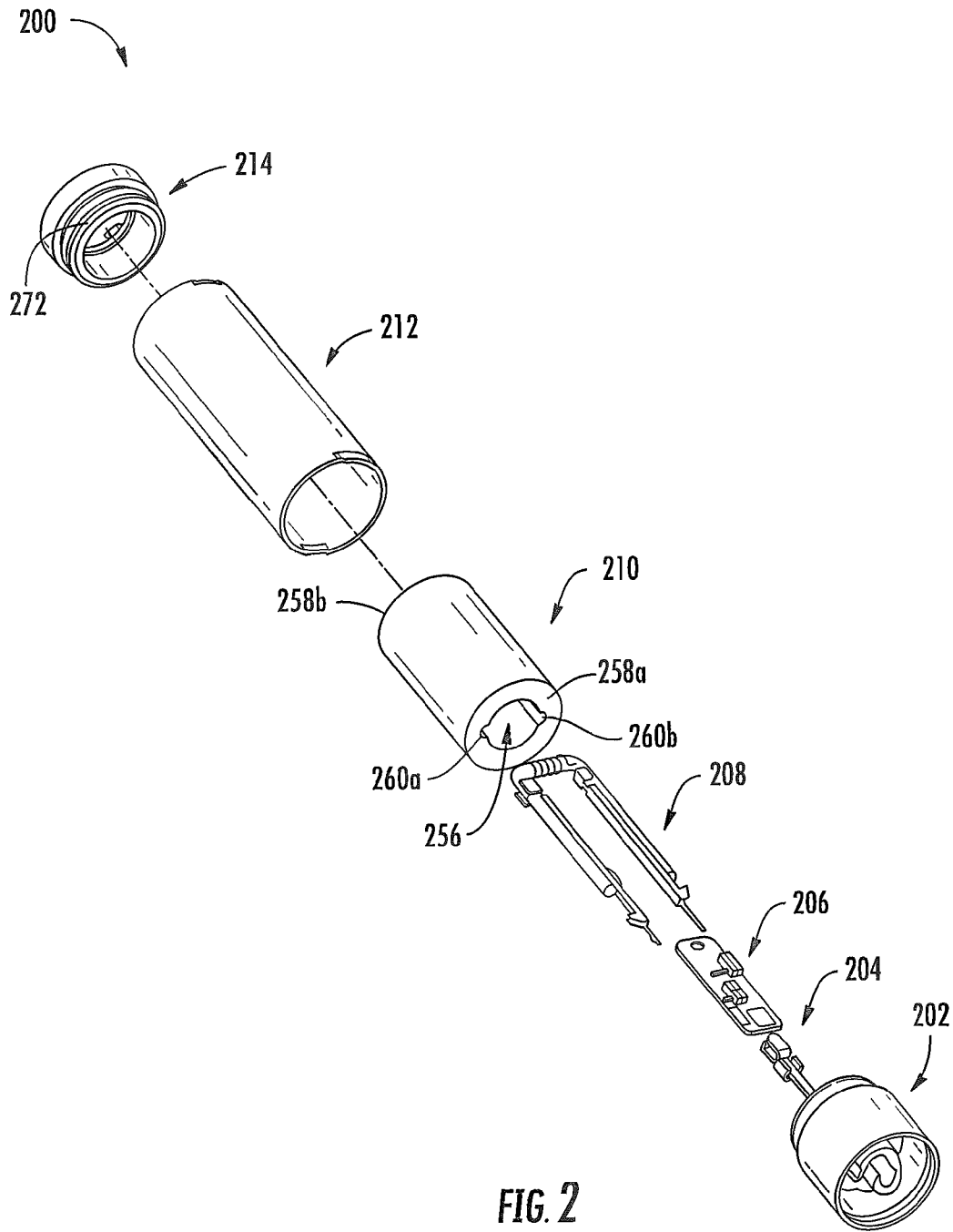
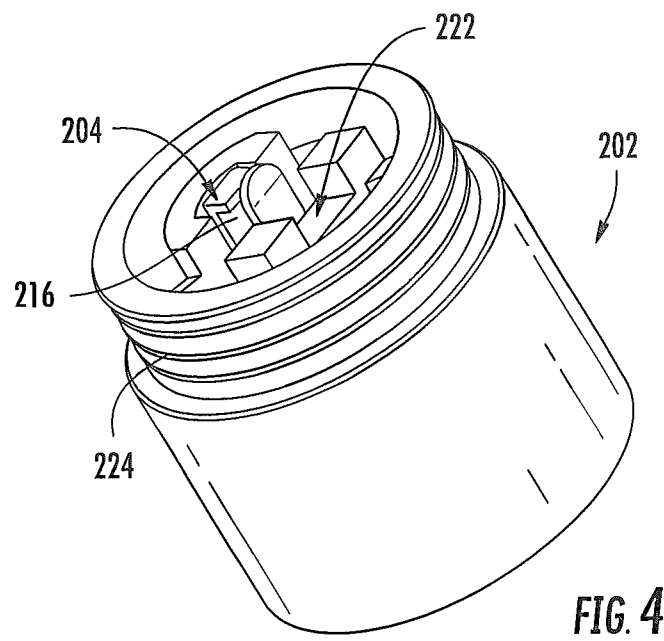
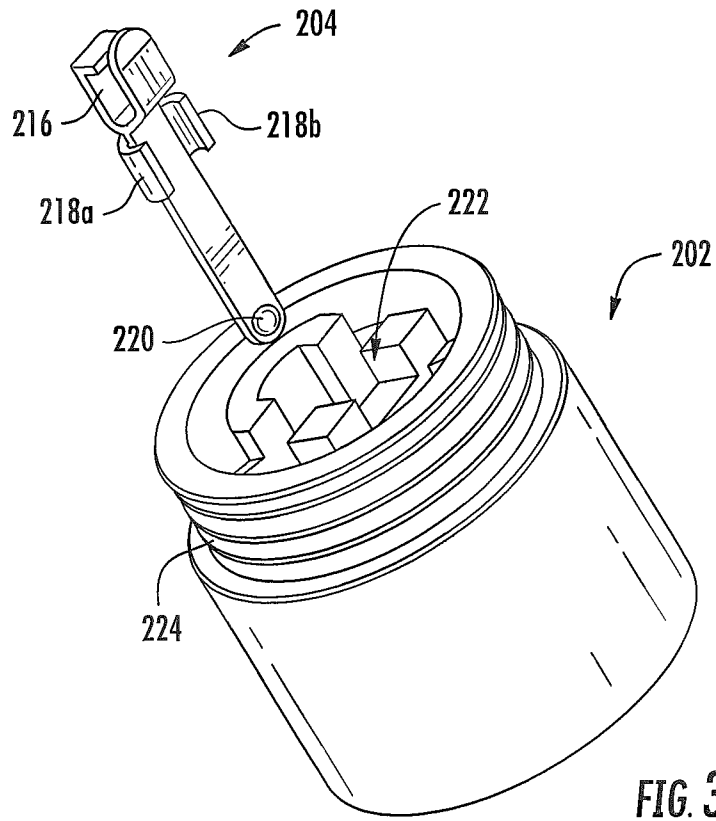

FIG. 2



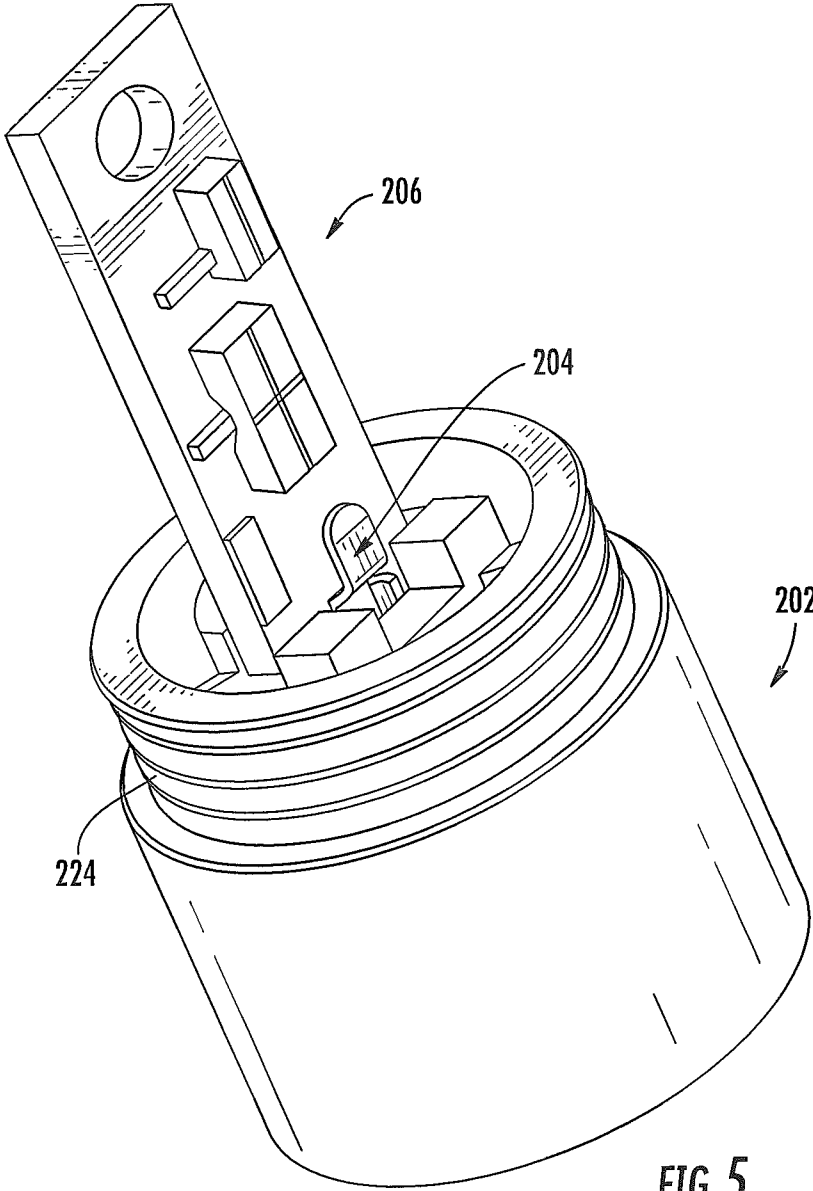

FIG. 5

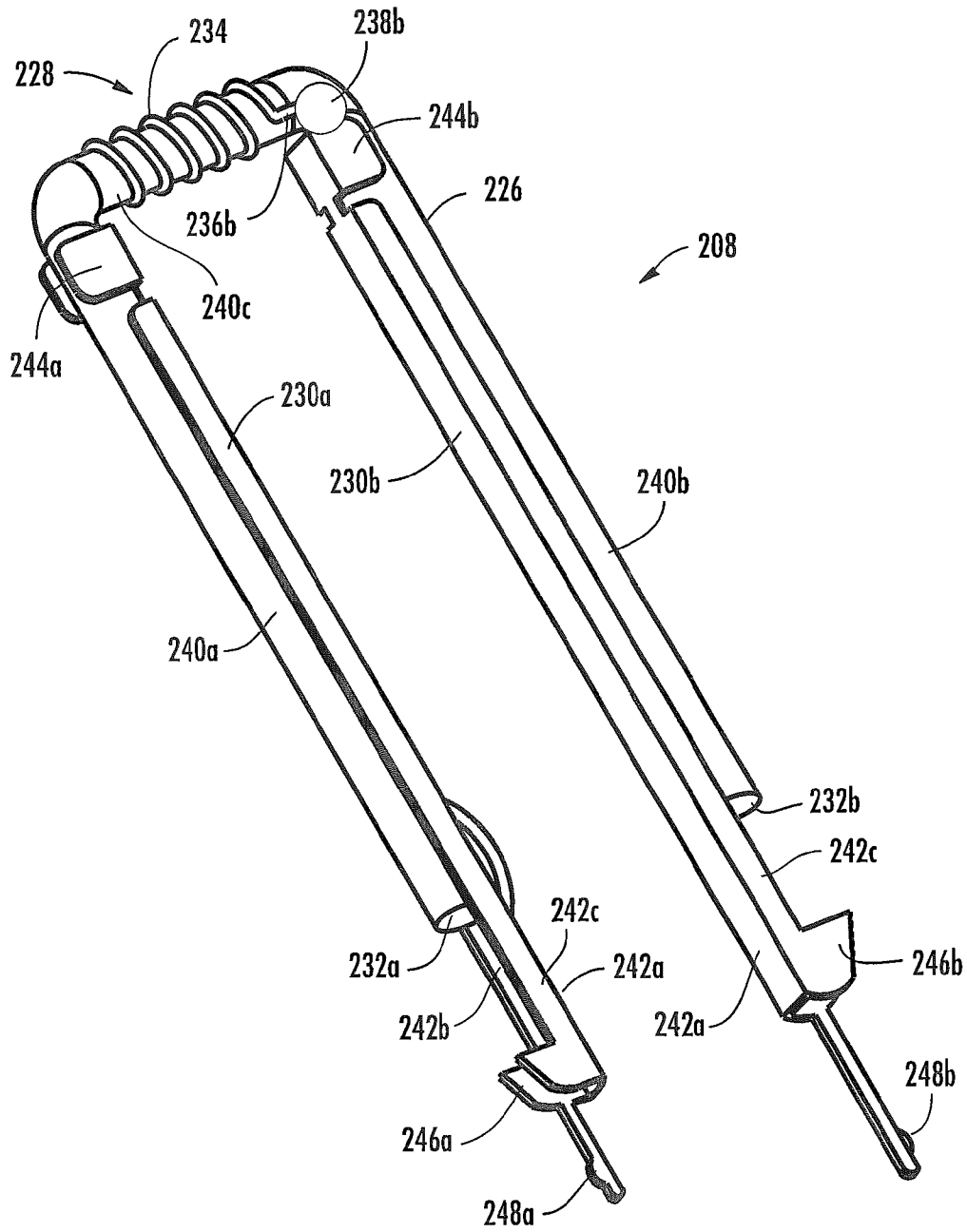

FIG. 6

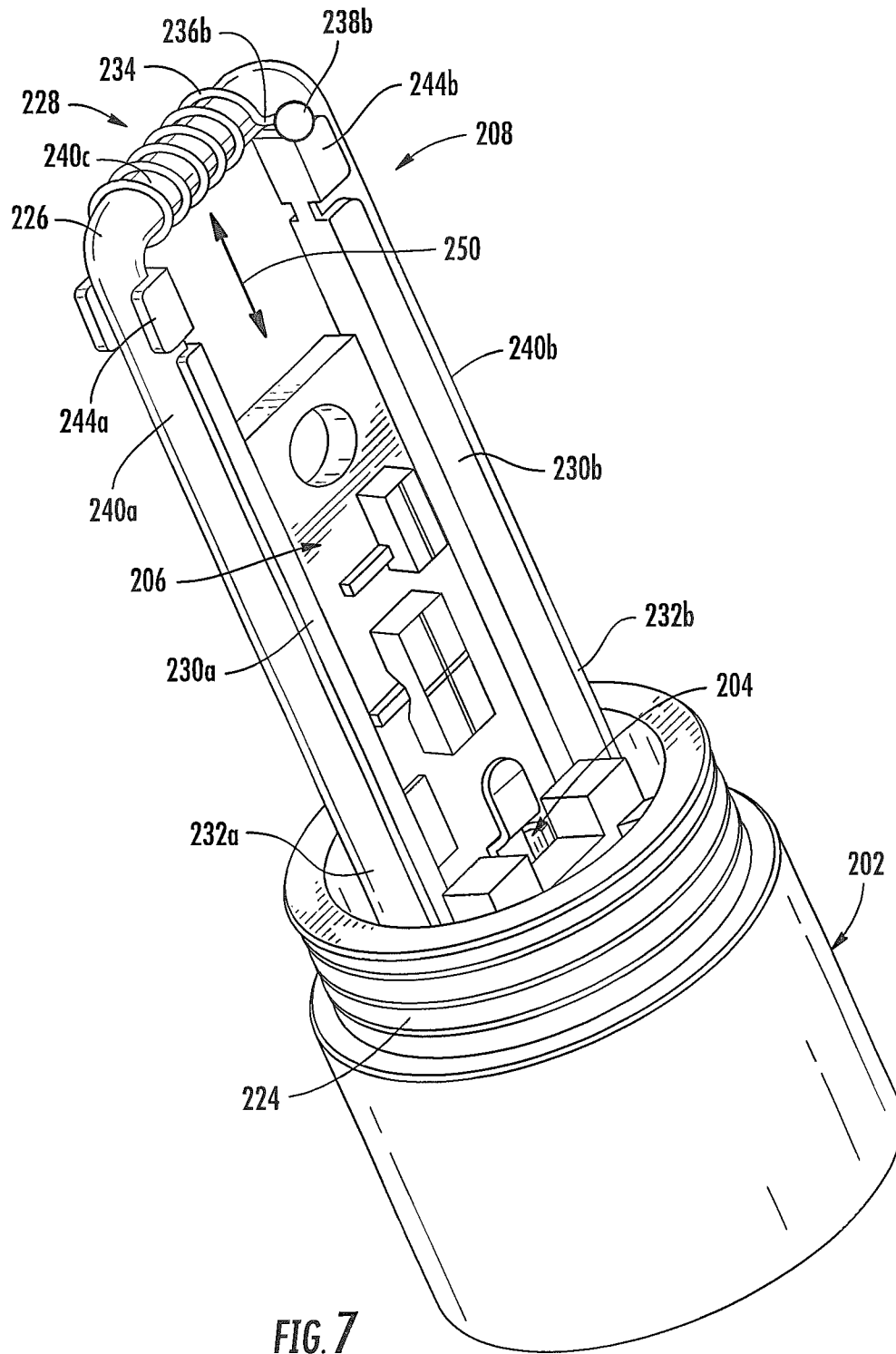
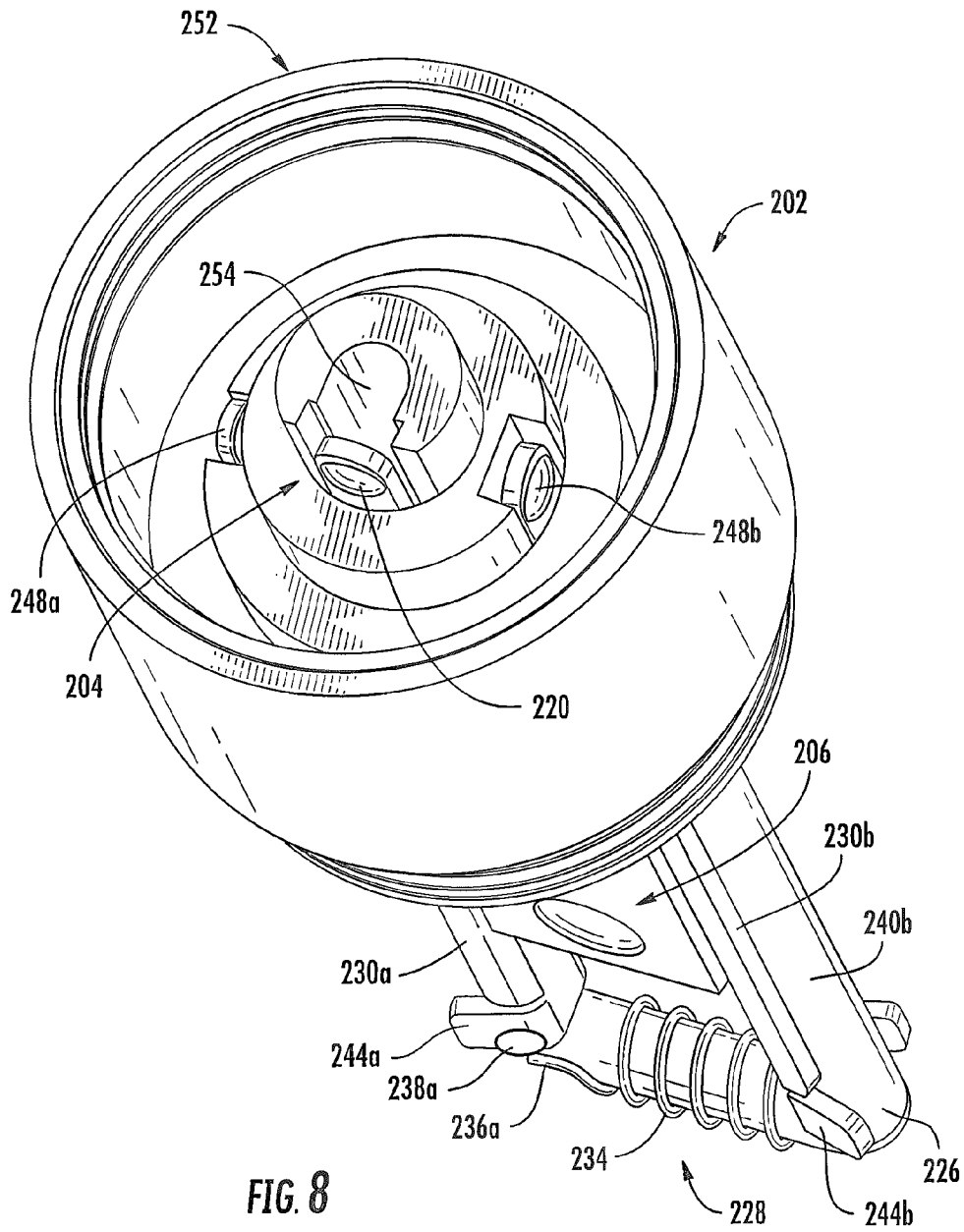

FIG. 7



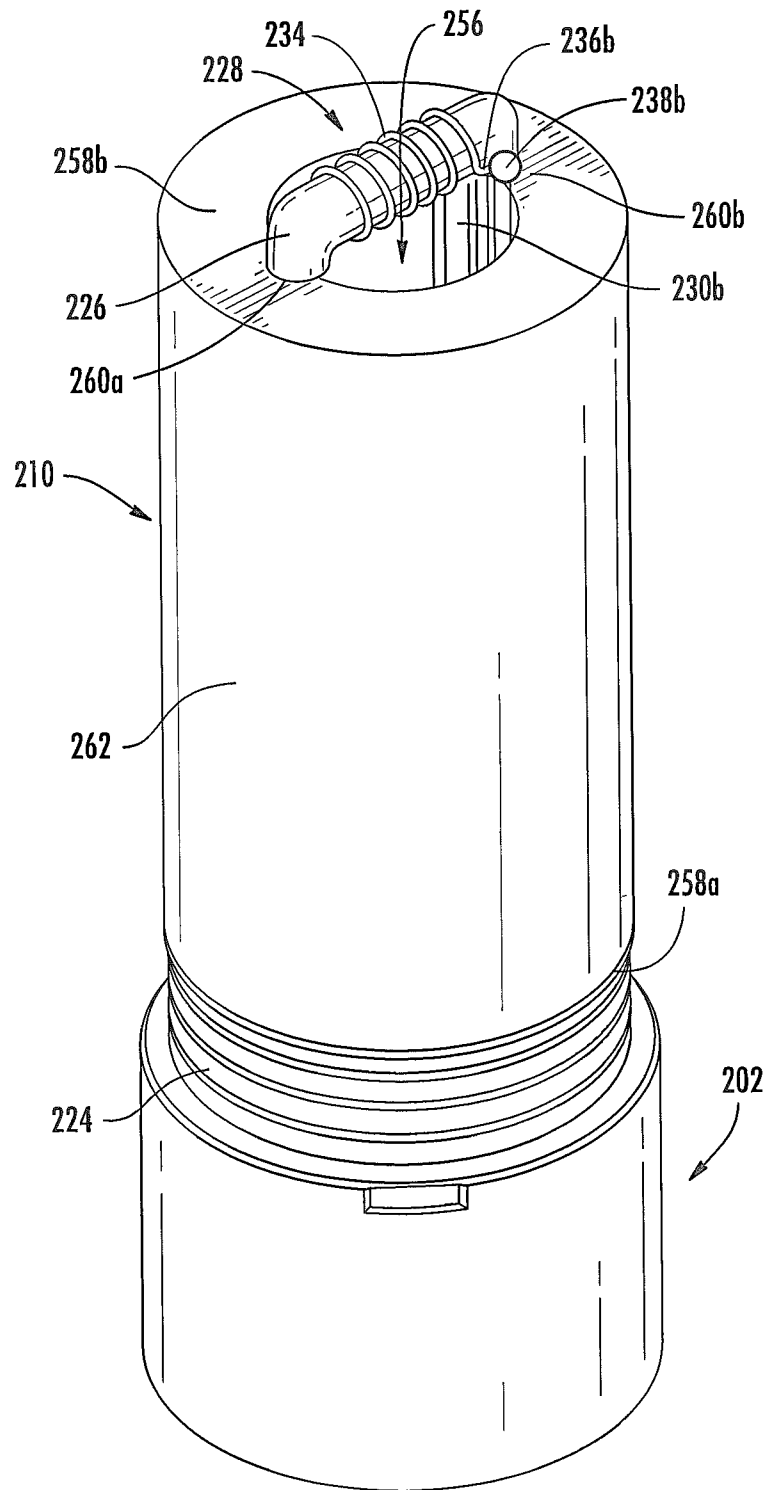

FIG. 9

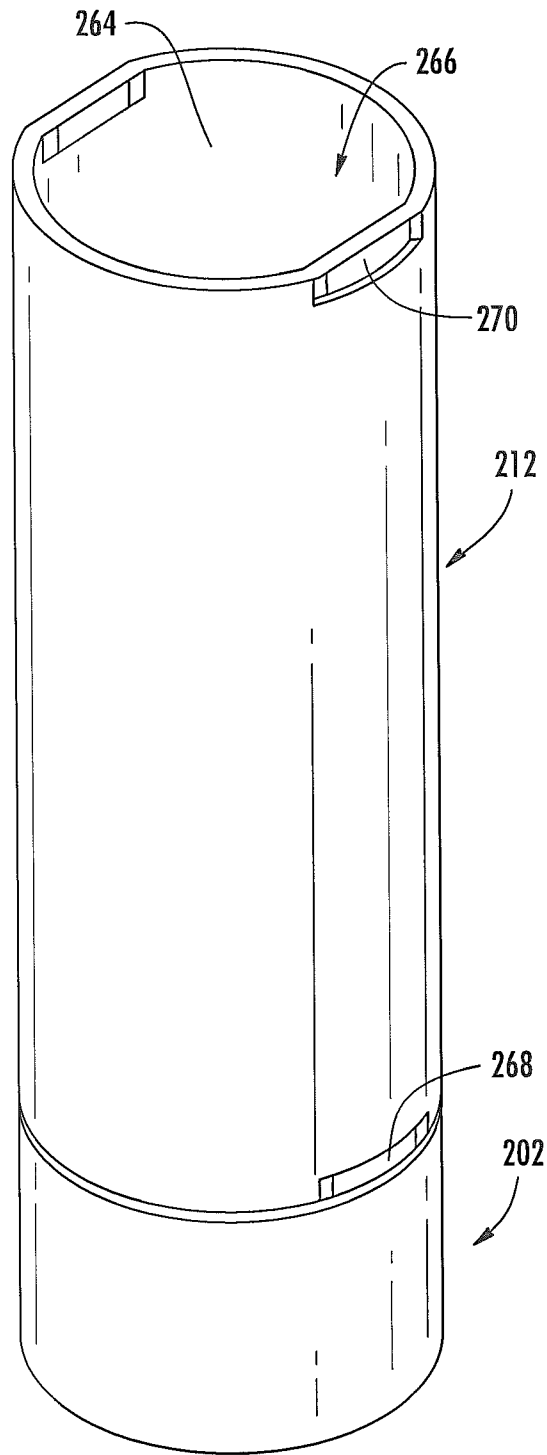

FIG. 10

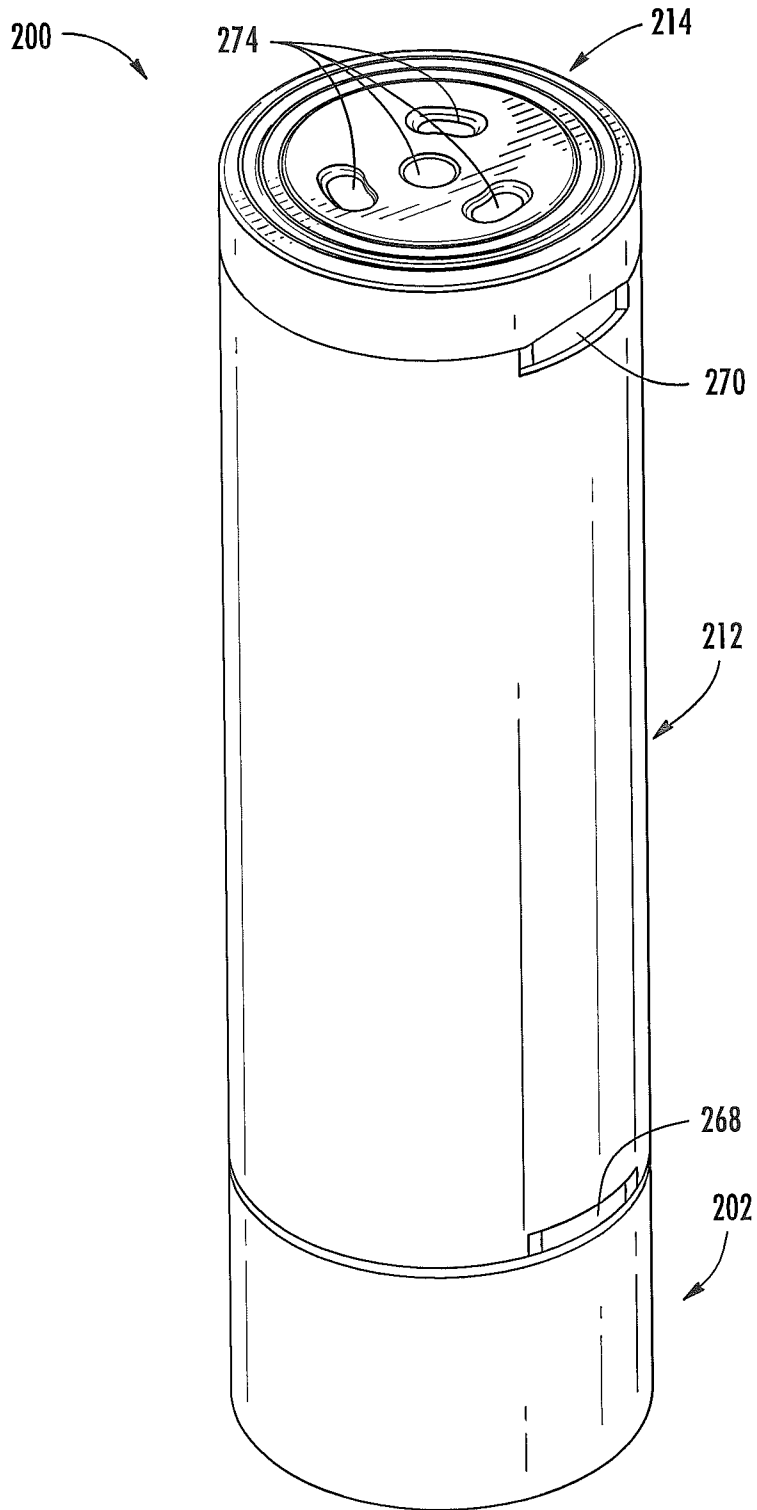

FIG. 11

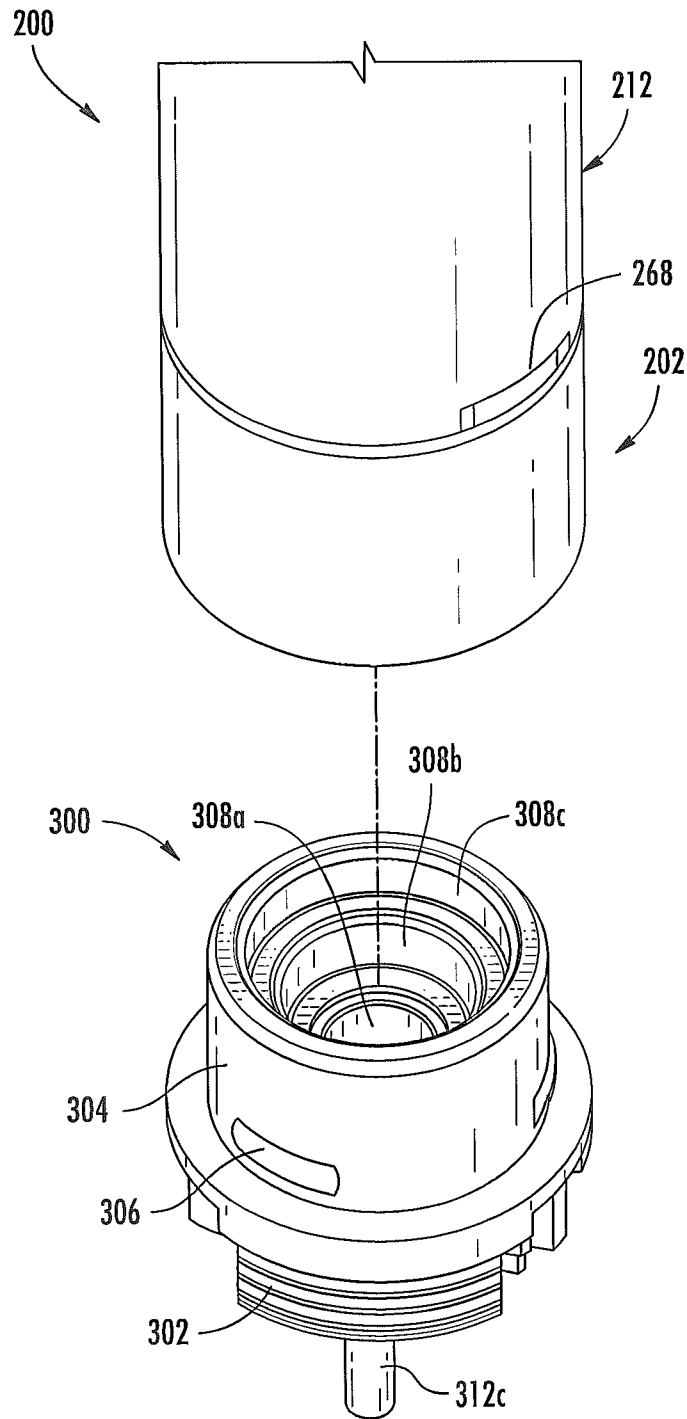

FIG. 12

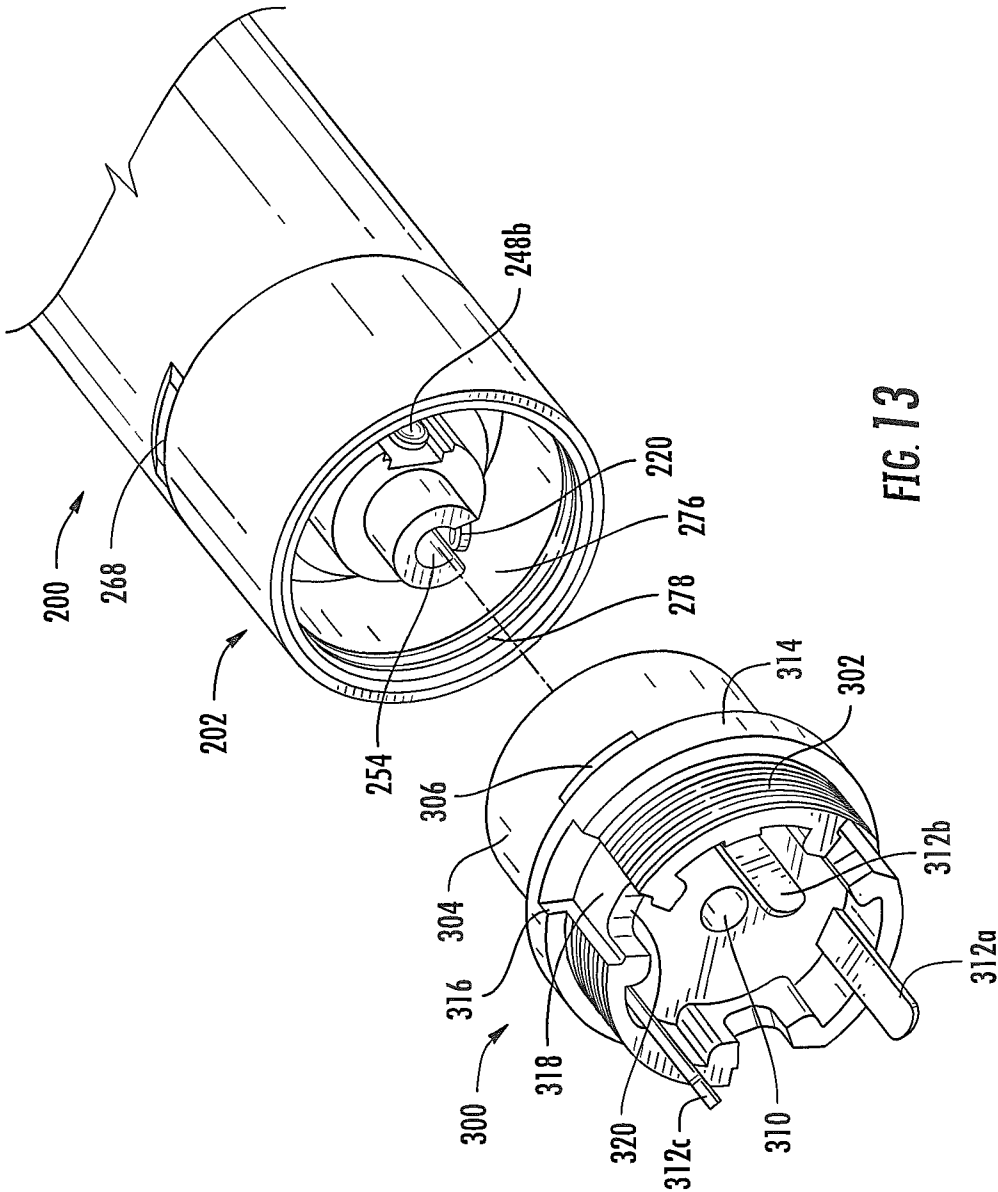

FIG. 13

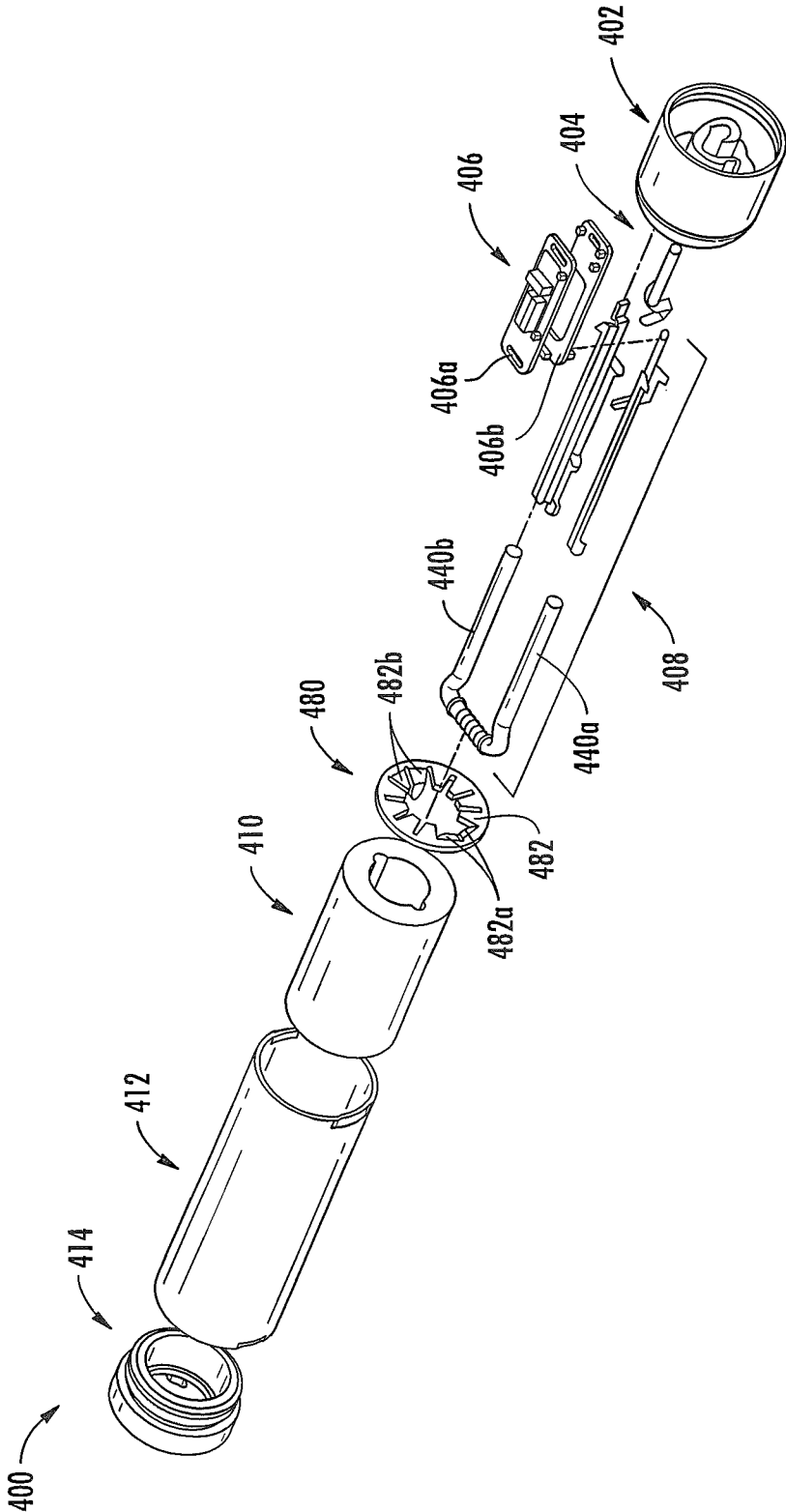

FIG. 14

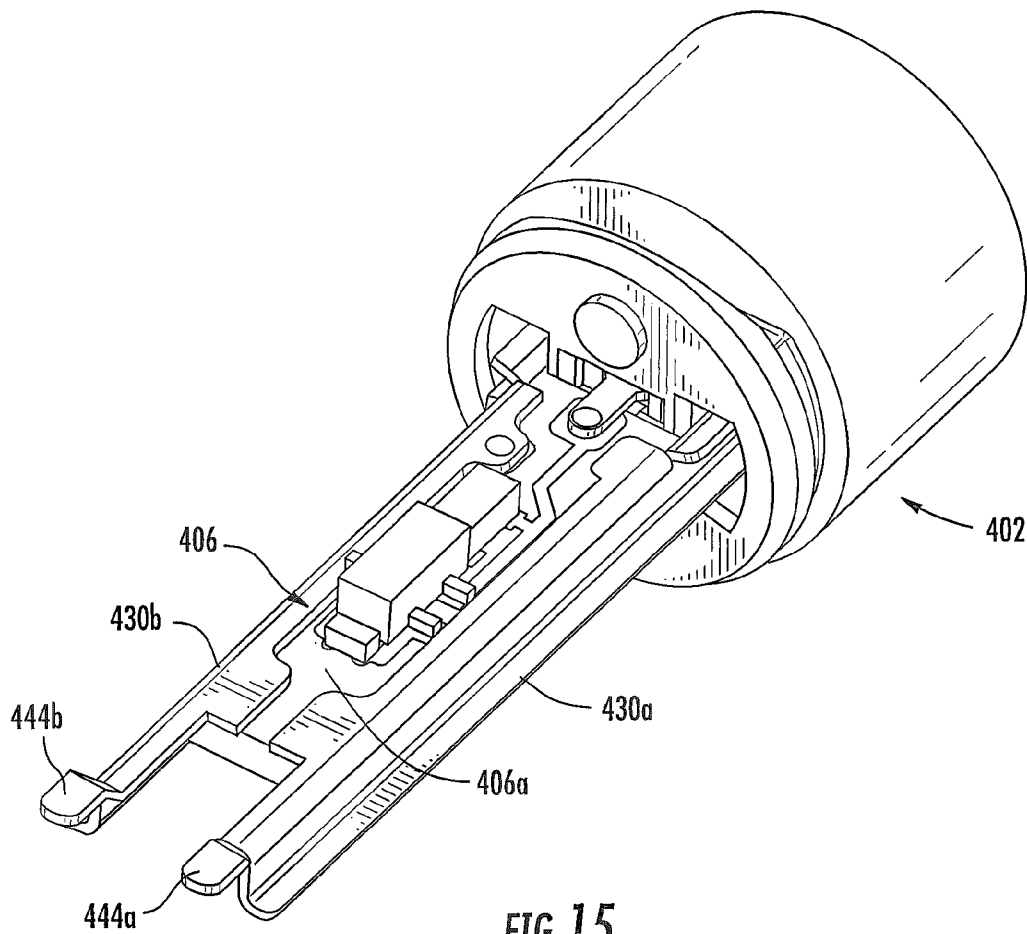

FIG. 15

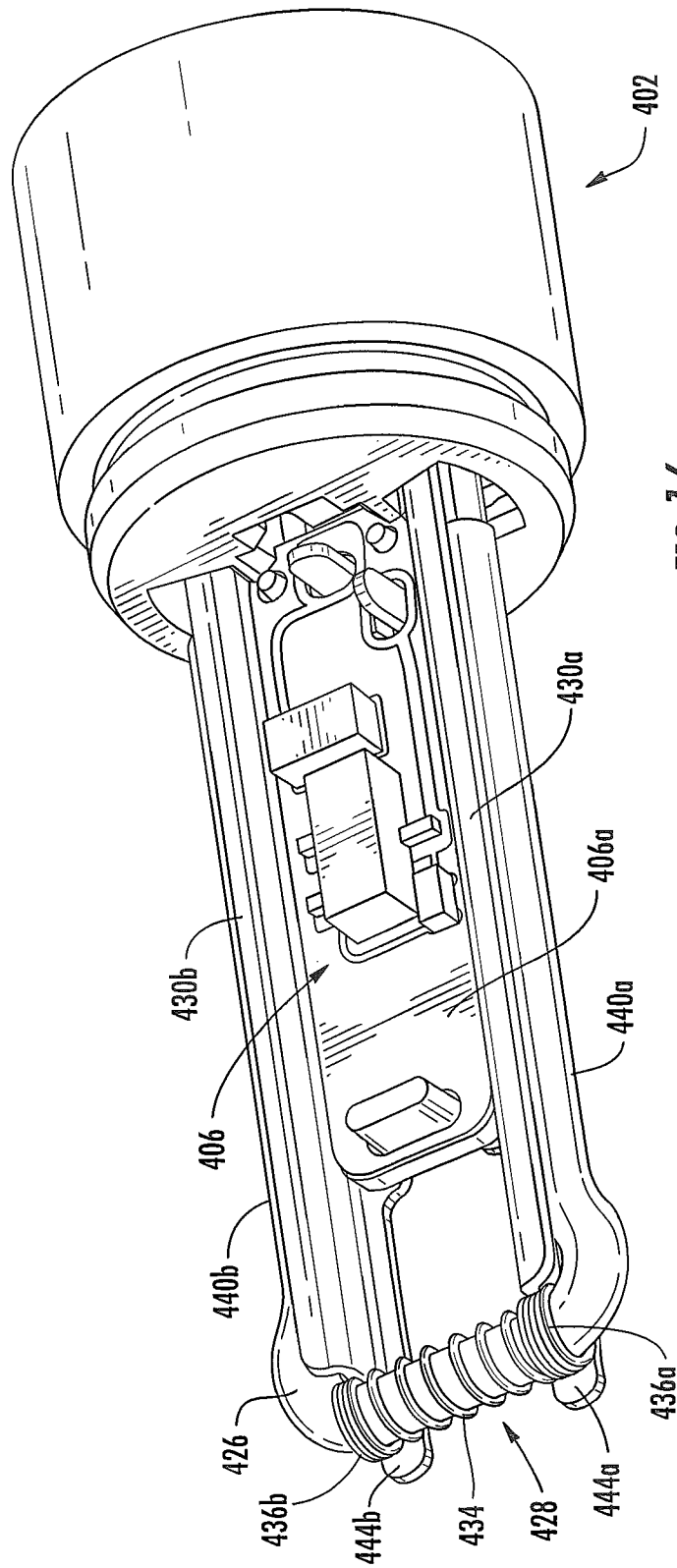

FIG. 16

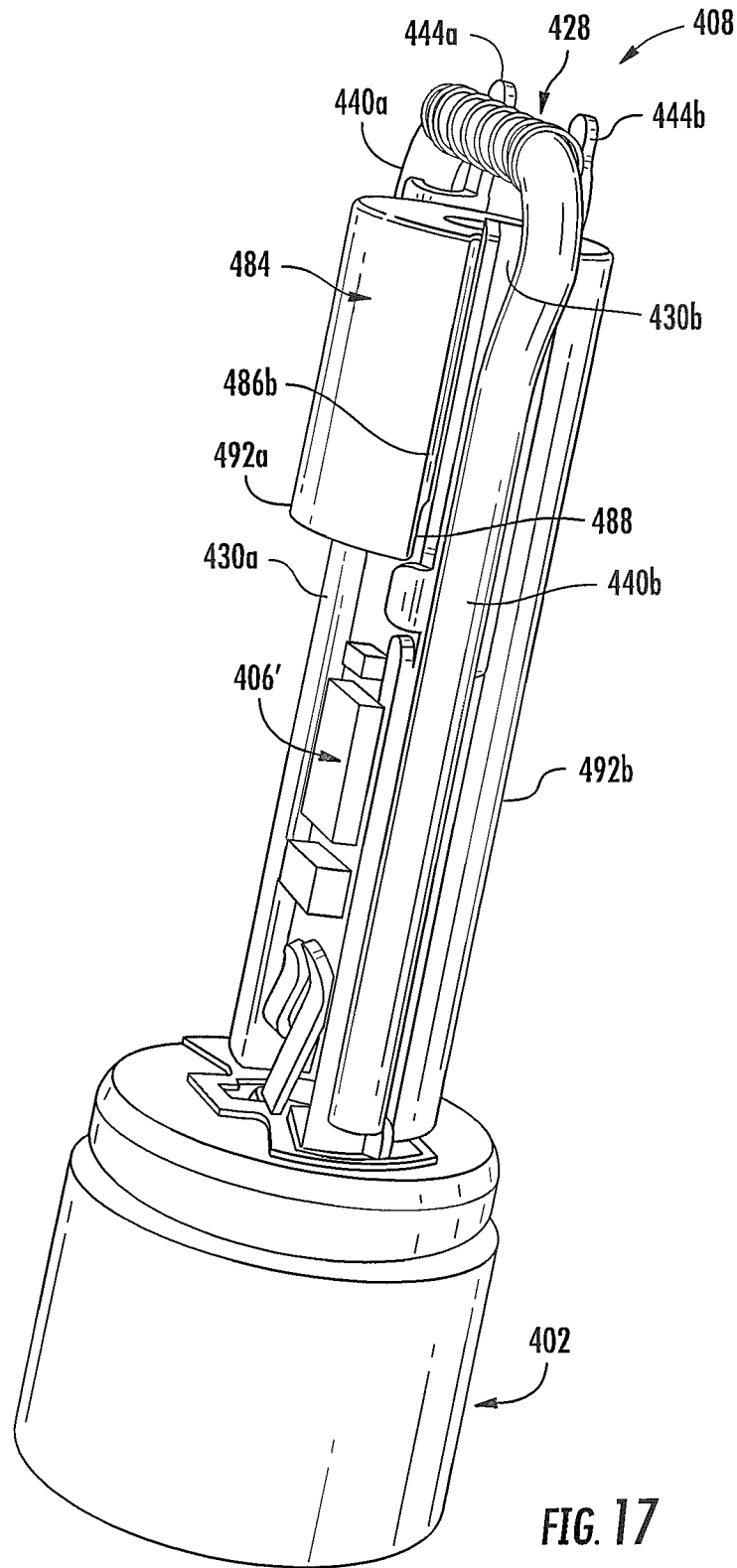

FIG. 17

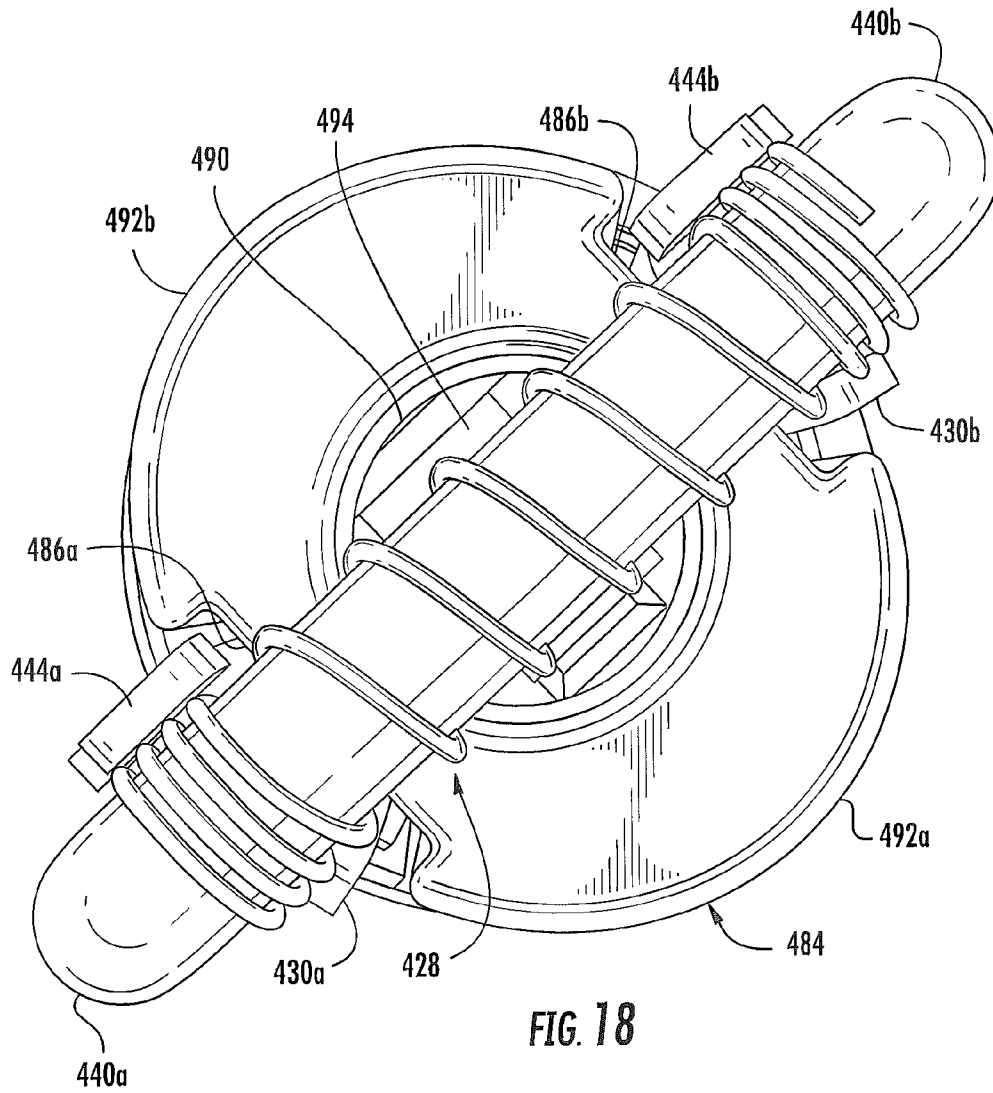

FIG. 18

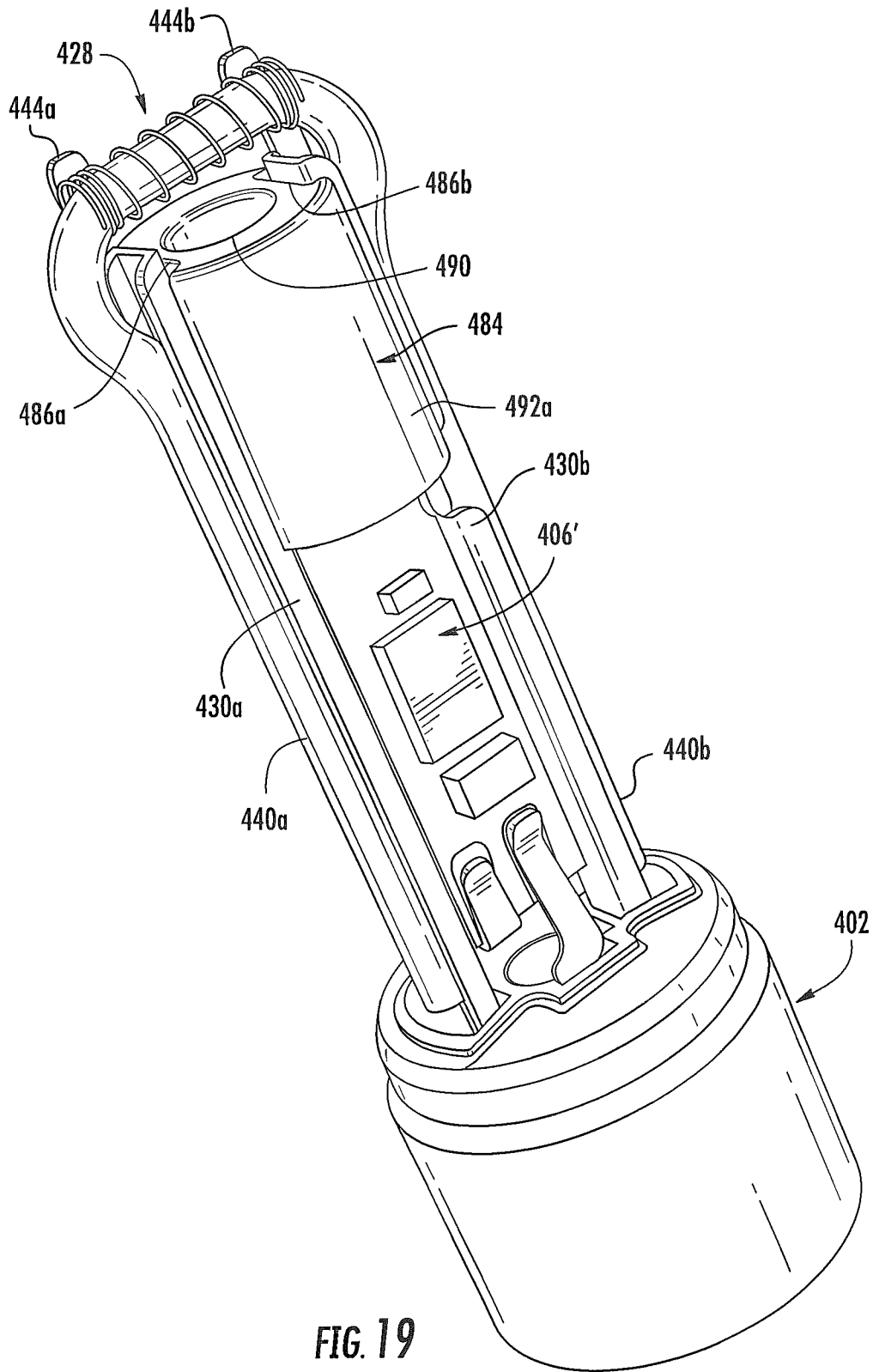

FIG. 19

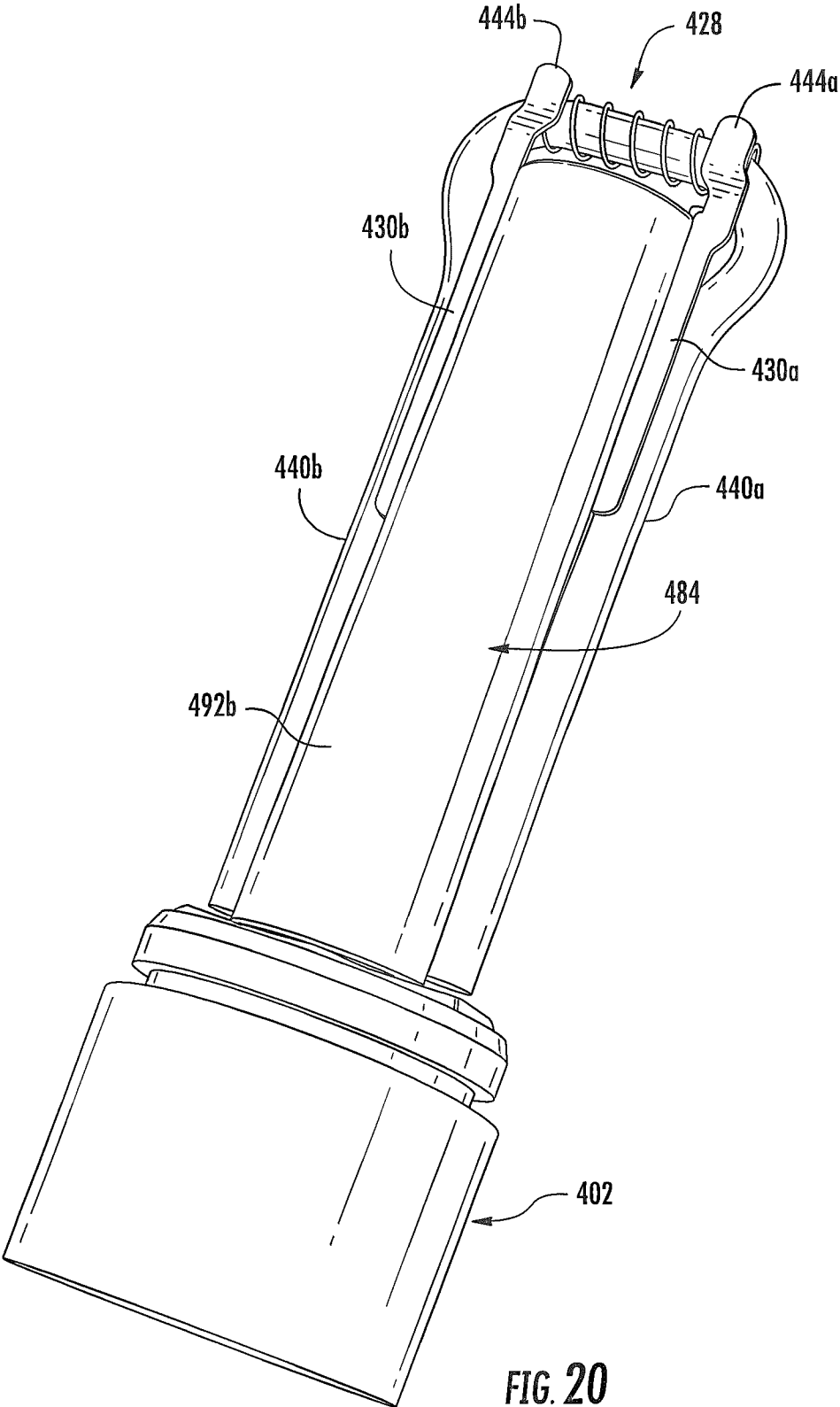

FIG. 20

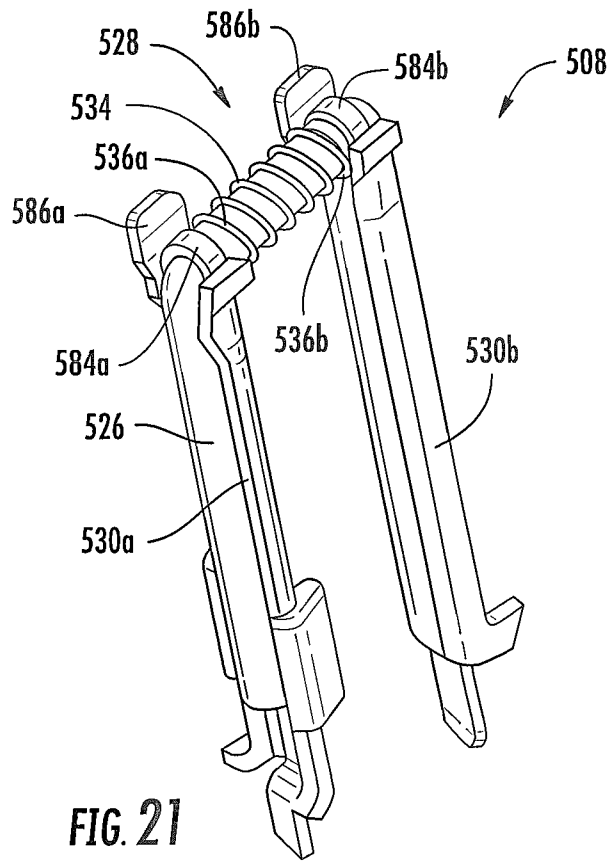

FIG. 21

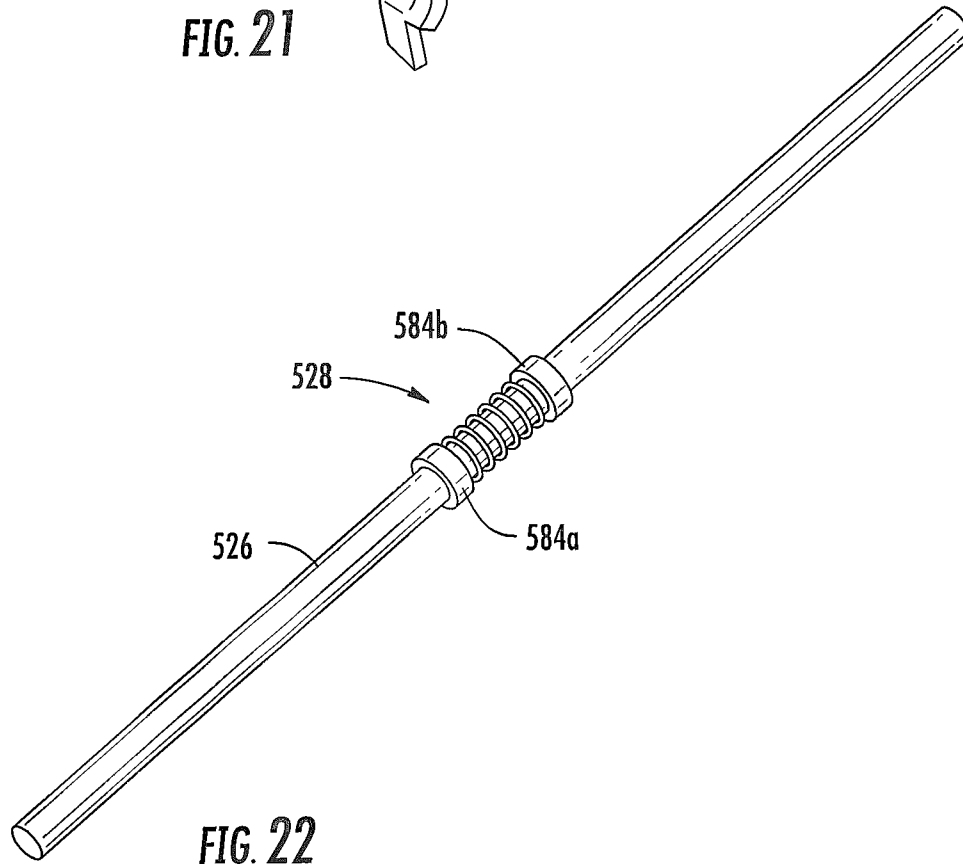

FIG. 22

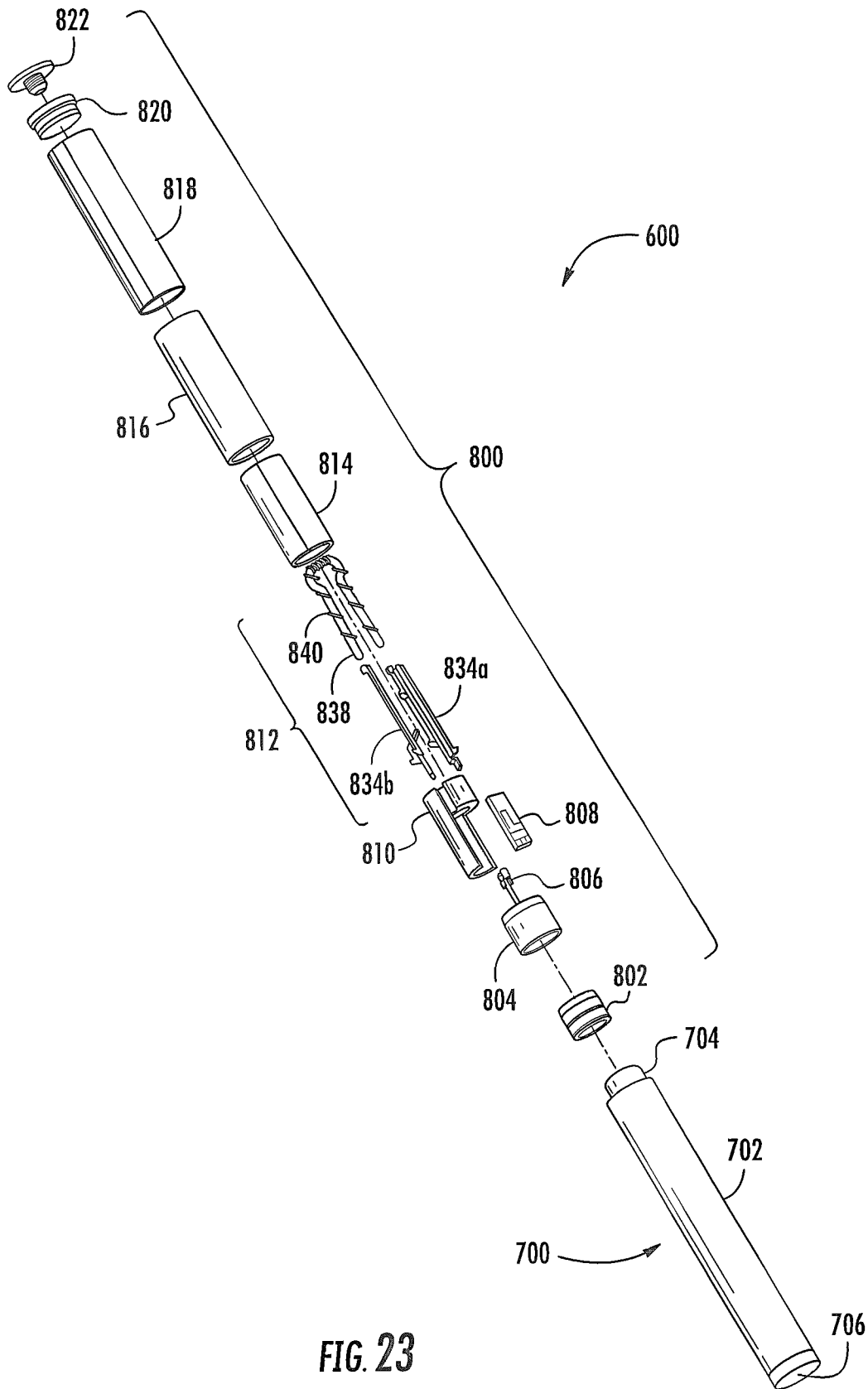

FIG. 23

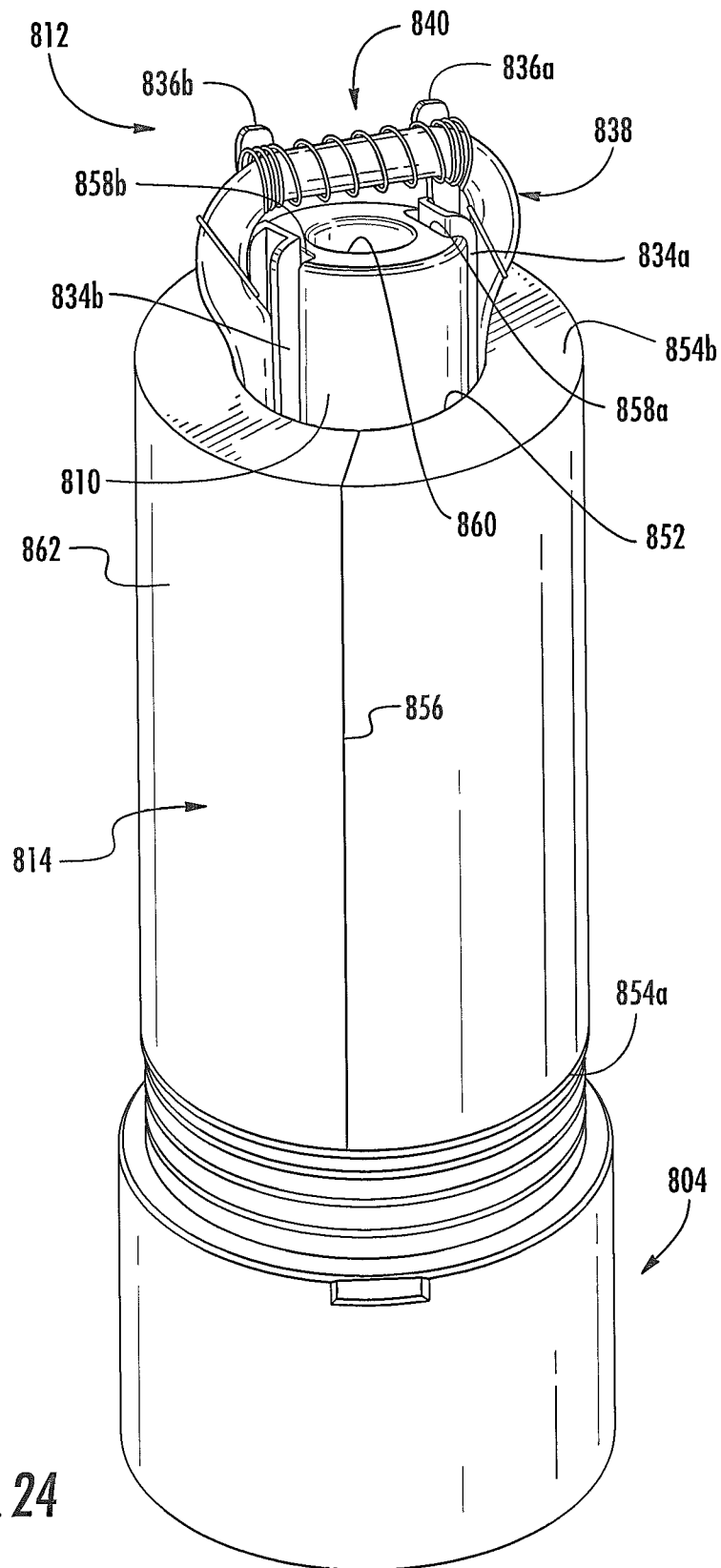

FIG. 24

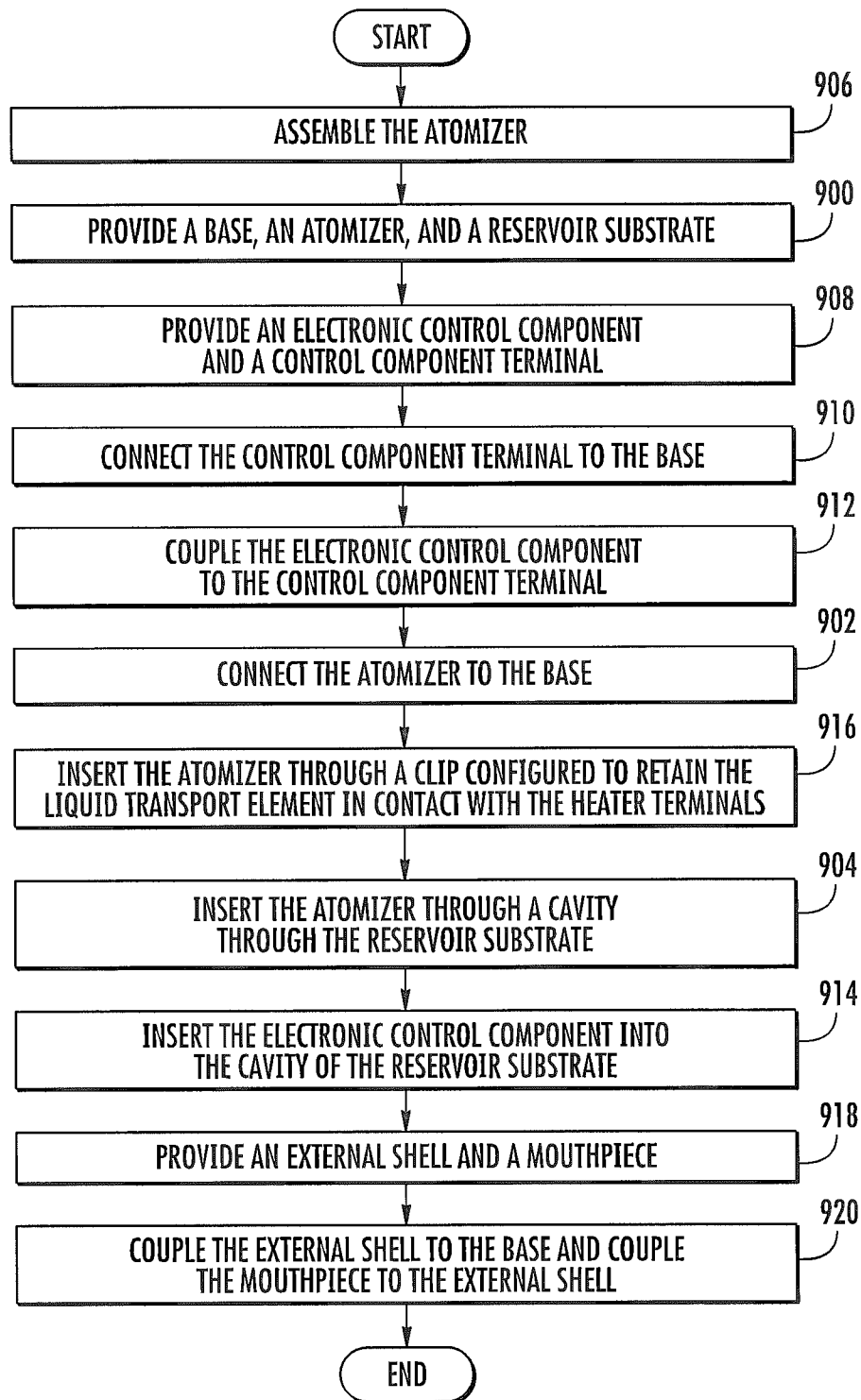

FIG. 25

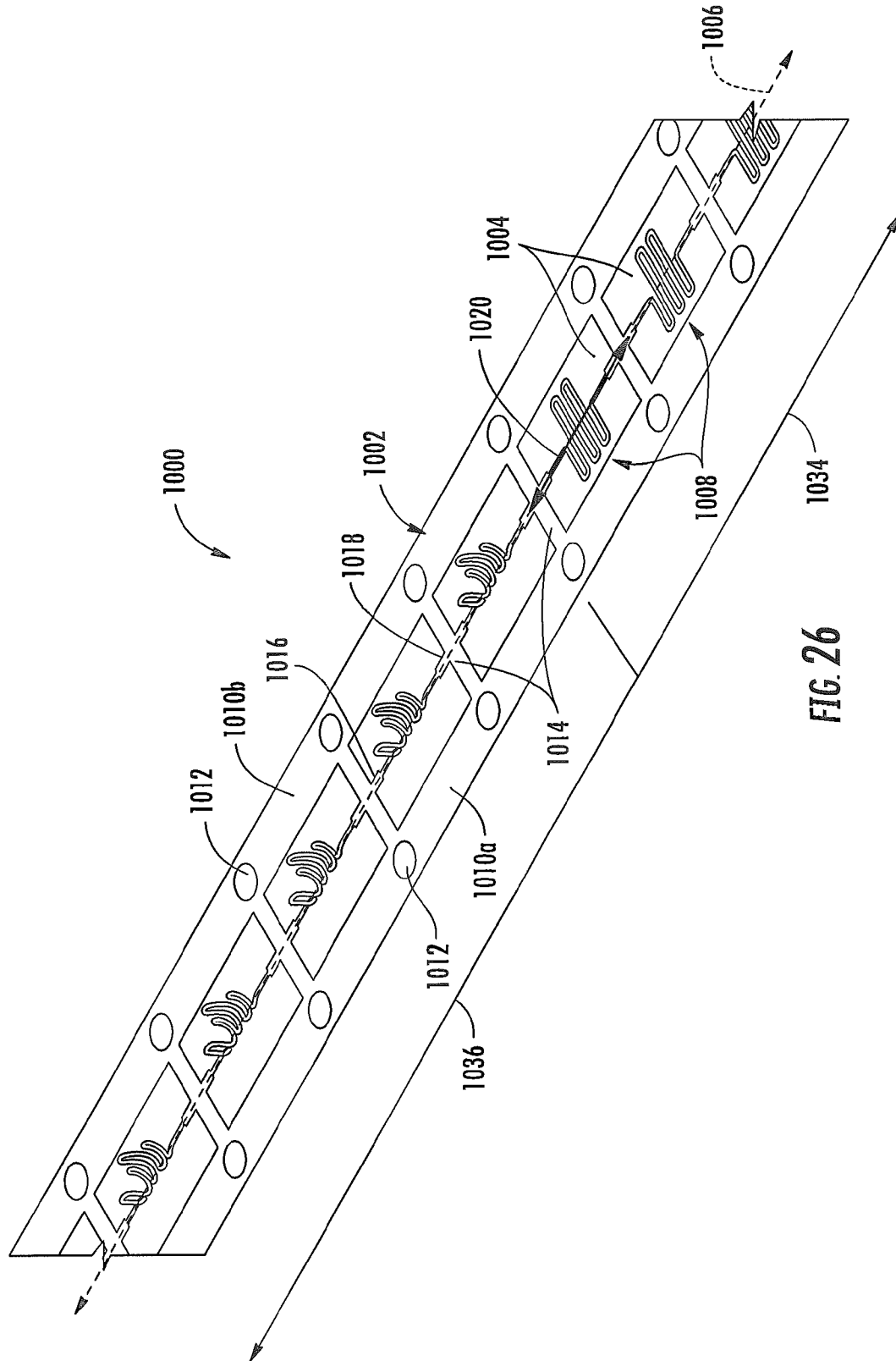
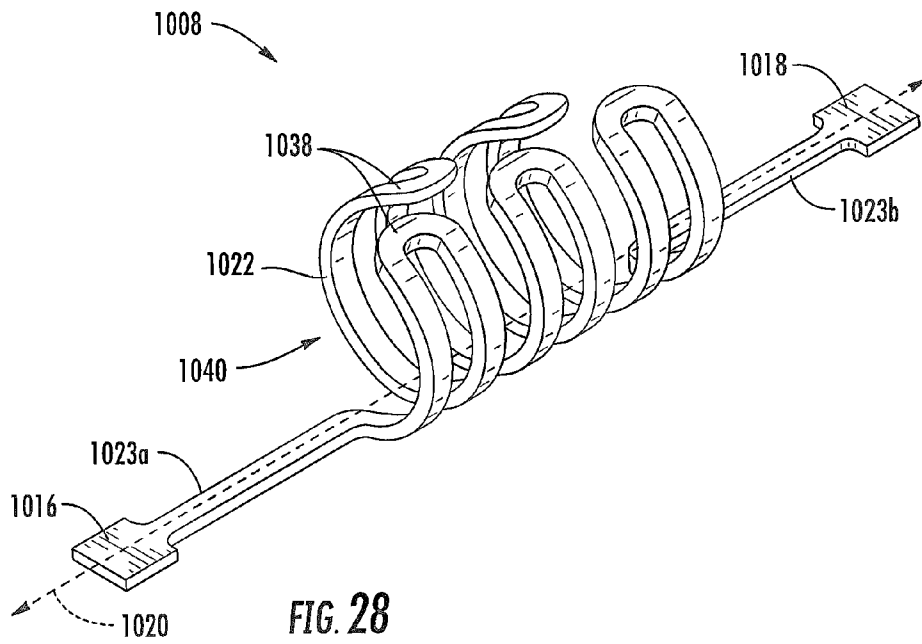
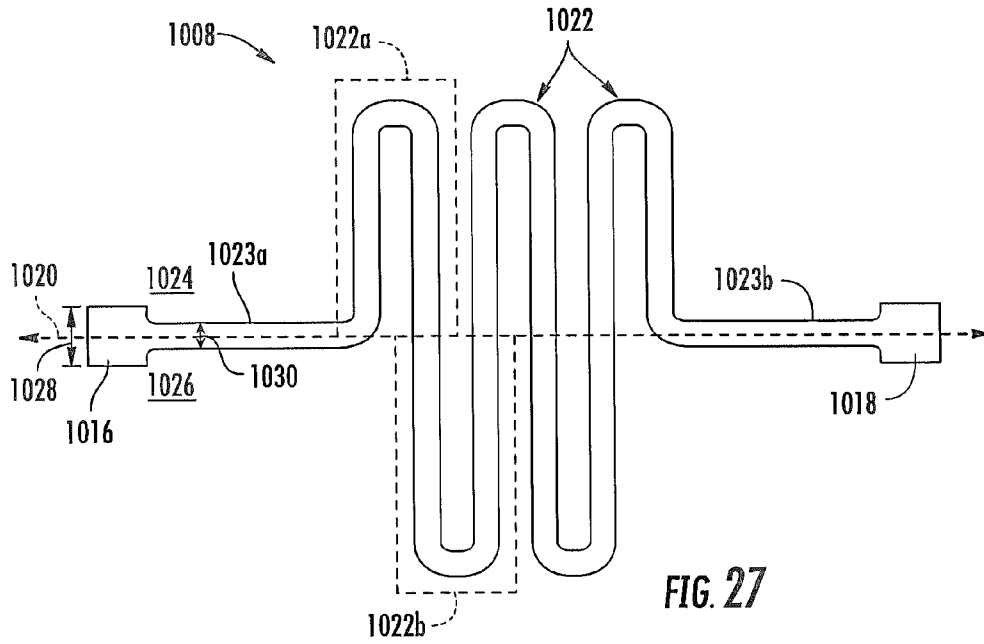
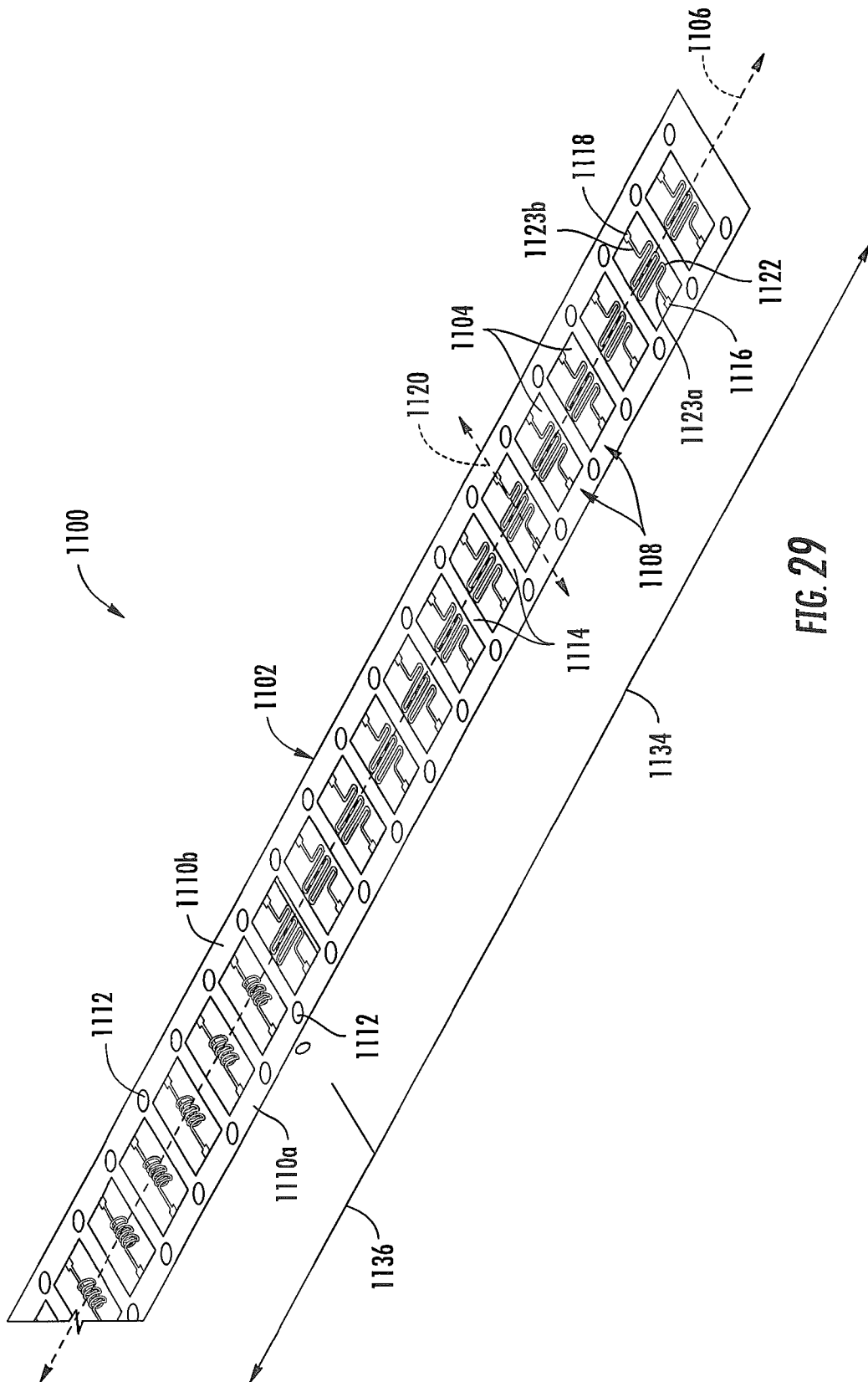

FIG. 26





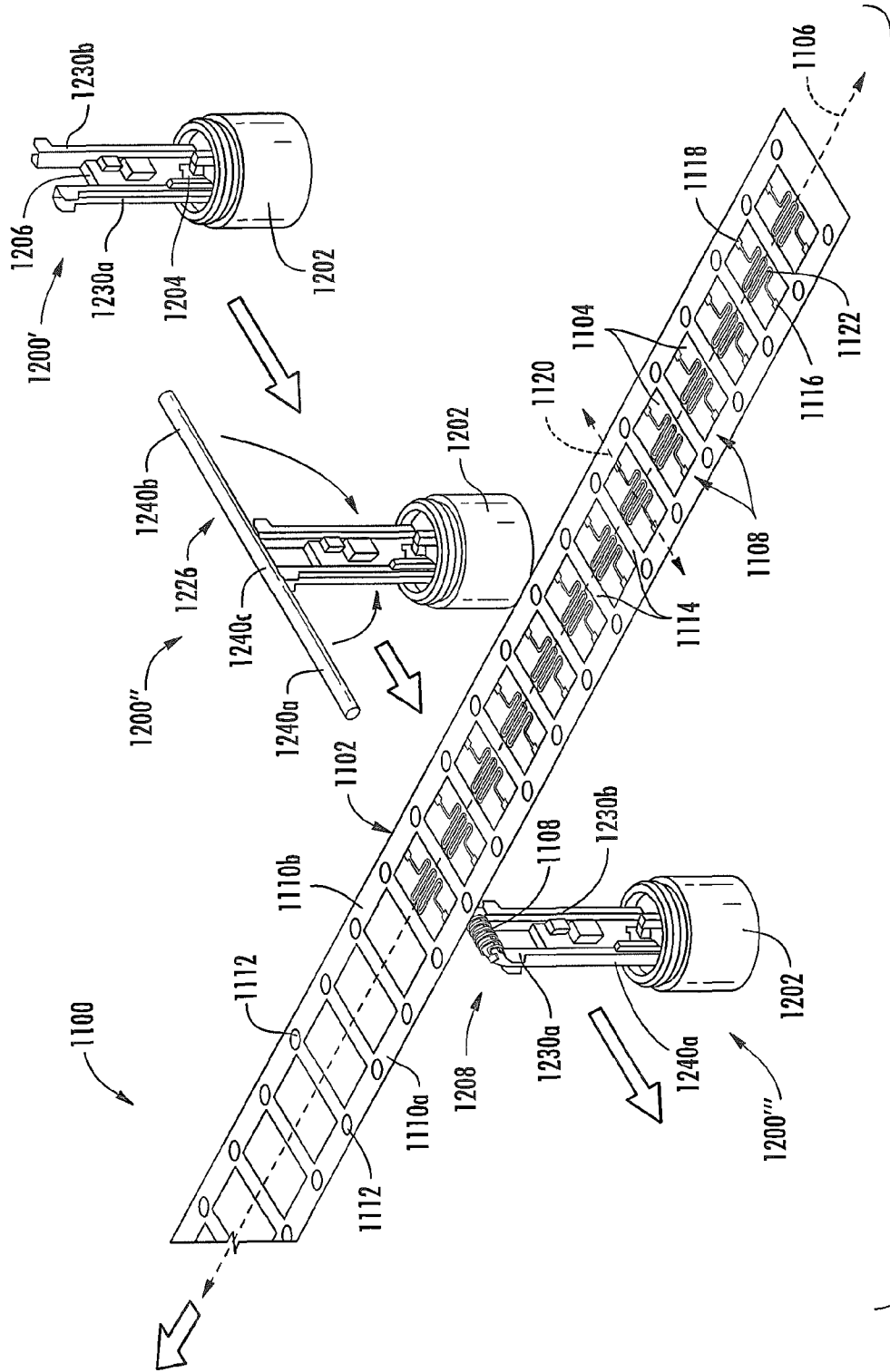

FIG. 30

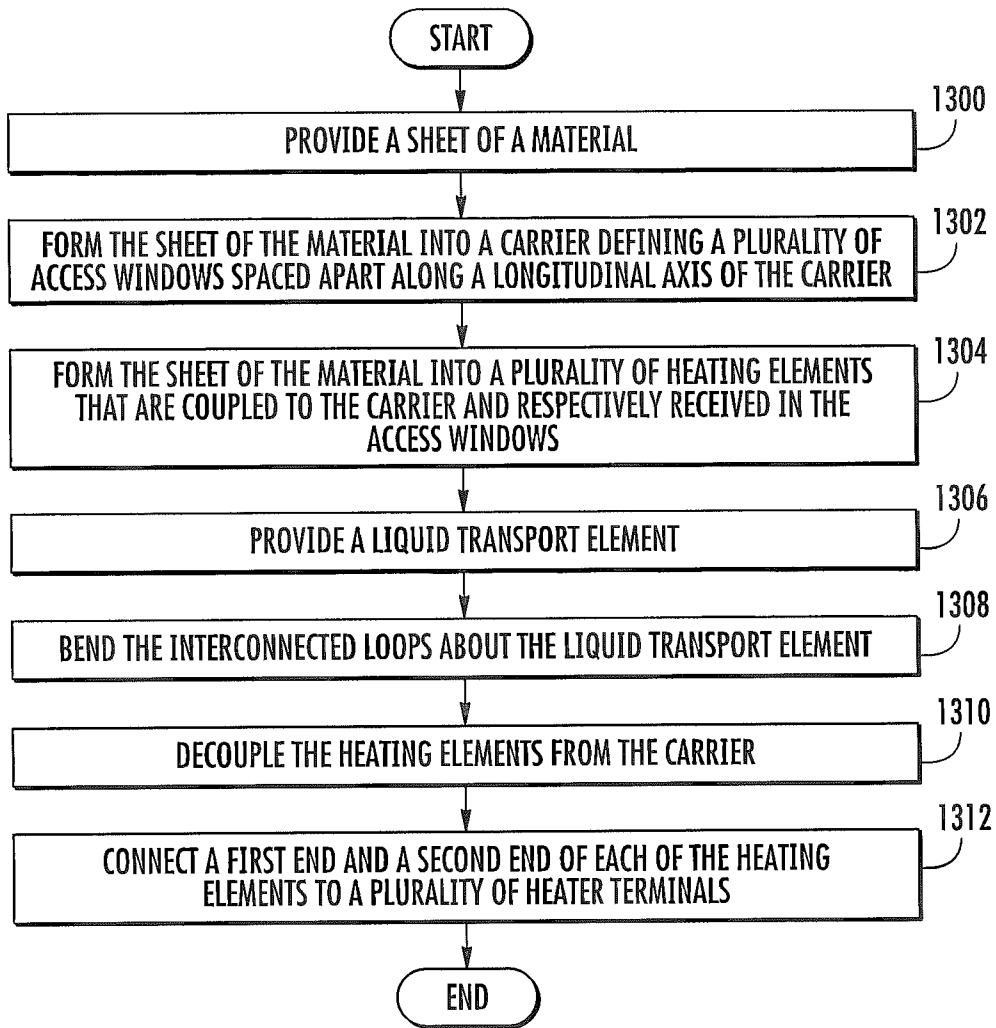

FIG. 31

**CARTRIDGE FOR AN AEROSOL DELIVERY
DEVICE AND METHOD FOR ASSEMBLING A
CARTRIDGE FOR A SMOKING ARTICLE**

FIELD OF THE DISCLOSURE

The present disclosure relates to a cartridge for aerosol delivery devices such as smoking articles, and more particularly to a cartridge for smoking articles including an atomizer received through a reservoir substrate. The atomizer may be configured to heat an aerosol precursor, which may be made or derived from tobacco or otherwise incorporate tobacco, to form an inhalable substance for human consumption.

BACKGROUND

Many smoking devices have been proposed through the years as improvements upon, or alternatives to, smoking products that require combusting tobacco for use. Many of those devices purportedly have been designed to provide the sensations associated with cigarette, cigar, or pipe smoking, but without delivering considerable quantities of incomplete combustion and pyrolysis products that result from the burning of tobacco. To this end, there have been proposed numerous smoking products, flavor generators, and medicinal inhalers that utilize electrical energy to vaporize or heat a volatile material, or attempt to provide the sensations of cigarette, cigar, or pipe smoking without burning tobacco to a significant degree. See, for example, the various alternative smoking articles, aerosol delivery devices and heat generating sources set forth in the background art described in U.S. Pat. No. 7,726,320 to Robinson et al., U.S. patent application Ser. No. 13/432,406, filed Mar. 28, 2012, U.S. patent application Ser. No. 13/536,438, filed Jun. 28, 2012, U.S. patent application Ser. No. 13/602,871, filed Sep. 4, 2012, and U.S. patent application Ser. No. 13/647,000, filed Oct. 8, 2012, which are incorporated herein by reference. Certain tobacco products that have employed electrical energy to produce heat for smoke or aerosol formation, and in particular, certain products that have been referred to as electronic cigarette products, have been commercially available throughout the world. Representative products that resemble many of the attributes of traditional types of cigarettes, cigars or pipes have been marketed as ACCORD® by Philip Morris Incorporated; ALPHA™, JOYE 510™ and M4™ by InnoVapor LLC; CIRRUS™ and FLING™ by White Cloud Cigarettes; COHITA™, COLIBRI™, ELITE CLASSIC™, MAGNUM™, PHANTOM™ and SENSE™ by Epuffer® International Inc.; DUOPRO™, STORM™ and VAPORKING® by Electronic Cigarettes, Inc.; EGAR™ by Egar Australia; eGo-C™ and eGo-T™ by Joyetech; ELUSION™ by Elusion UK Ltd; EONSMOKE® by Eonsmoke LLC; GREEN SMOKE® by Green Smoke Inc. USA; GREENARETTE™ by Greenarette LLC; HALLIGAN™, HENDU™, JET™, MAXXQ™, PINK™ and PITBULL™ by Smoke Stik®; HEATBAR™ by Philip Morris International, Inc.; HYDRO IMPERIAL™ and LXE™ from Crown7; LOGIC™ and THE CUBAN™ by LOGIC Technology; LUCI® by Luciano Smokes Inc.; METRO® by Nicotek, LLC; NJOY® and ONEJOY™ by Sottera, Inc.; NO. 7™ by SS Choice LLC; PREMIUM ELECTRONIC CIGARETTE™ by PremiumEstore LLC; RAPP E-MYSTICK™ by Ruyan America, Inc.; RED DRAGON™ by Red Dragon Products, LLC; RUYAN® by Ruyan Group (Holdings) Ltd.; SMART SMOKER® by The Smart Smoking Electronic Cigarette Company Ltd.; SMOKE ASSIST® by Coastline Products LLC; SMOKING EVERYWHERE® by Smoking Everywhere, Inc.; V2CIGS™ by

VMR Products LLC; VAPOR NINE™ by VaporNine LLC; VAPOR4LIFE® by Vapor 4 Life, Inc.; VEPPO™ by E-CigaretteDirect, LLC and VUSE® by R. J. Reynolds Vapor Company. Yet other electrically powered aerosol delivery devices, and in particular those devices that have been characterized as so-called electronic cigarettes, have been marketed under the tradenames BLU™; COOLER VISIONS™; DIRECT E-CIG™; DRAGONFLY™; EMIST™; EVERSMOKE™; GAMUCCI®; HYBRID FLAME™; KNIGHT STICKS™; ROYAL BLUES™; SMOKETIP® and SOUTH BEACH SMOKE™.

It would be desirable to provide a smoking article that employs heat produced by electrical energy to provide the sensations of cigarette, cigar, or pipe smoking, that does so without combusting tobacco to any significant degree, that does so without the need of a combustion heat source, and that does so without necessarily delivering considerable quantities of incomplete combustion and pyrolysis products. Thus, advances with respect to manufacturing electronic smoking articles would be desirable.

BRIEF SUMMARY OF THE DISCLOSURE

The present disclosure relates to aerosol delivery devices configured to produce aerosol. In one aspect a cartridge for an aerosol delivery device such as a smoking article is provided. The cartridge may include a base defining a connector end configured to engage a control body. The cartridge may additionally include a reservoir substrate configured to hold an aerosol precursor composition. The reservoir substrate may define a cavity extending therethrough from a first reservoir end to a second reservoir end, wherein the first reservoir end is positioned proximate the base. Further, the cartridge may include an atomizer. The atomizer may include a liquid transport element extending between a first liquid transport element end and a second liquid transport element end and a heating element extending at least partially about the liquid transport element at a position between the first liquid transport element end and the second liquid transport element end. The atomizer may extend through the cavity of the reservoir substrate such that the heating element is positioned proximate the second reservoir end and the first liquid transport element end and the second liquid transport element end are positioned proximate the first reservoir end.

In some embodiments the atomizer may further include two heater terminals connected to the base and the heating element. The reservoir substrate may define a plurality of grooves at the cavity extending between the first reservoir end and the second reservoir end and configured to receive the liquid transport element. The cartridge may further comprise a retainer clip surrounding the atomizer and configured to retain the liquid transport element in contact with the heater terminals. The heater terminals may extend through the reservoir substrate.

In some embodiments the cartridge may further comprise an electronic control component and a control component terminal coupled thereto. The electronic control component may be received in the cavity of the reservoir substrate and the control component terminal may be connected to the base. The control component terminal and the heater terminals may extend to a plurality of different depths within the base. The heating element may include a wire defining a plurality of coils wound about the liquid transport element and extending between a first wire end and a second wire end.

In some embodiments the atomizer may additionally include two connector rings surrounding the heating element at the first wire end and the second wire end. The heater

terminals may engage the connector rings. The heater terminals may directly contact the wire proximate the first wire end and the second wire end. A spacing of the coils of the wire may be less proximate the first wire end and the second wire end. In some embodiments the cartridge may further include a mouthpiece and an external shell.

In an additional aspect, a method for assembling a cartridge for an aerosol delivery device such as a smoking article is provided. The method may include providing a base defining a connector end configured to engage a control body, an atomizer, and a reservoir substrate configured to hold an aerosol precursor composition and defining a cavity extending therethrough from a first reservoir end to a second reservoir end, connecting the atomizer to the base, and inserting the atomizer through the cavity through the reservoir substrate.

In some embodiments the method may further include assembling the atomizer. Assembling the atomizer may include providing two heater terminals, a liquid transport element extending between a first liquid transport element end and a second liquid transport element end, and a heating element. Assembling the atomizer may further include wrapping the heating element at least partially about the liquid transport element and connecting the heating element to the heater terminals such that the heating element extends therebetween and a first distal arm of the liquid transport element and a second distal arm of the liquid transport element extend along the heater terminals.

In some embodiments connecting the atomizer to the base may include connecting the heater terminals to the base. Inserting the atomizer through the cavity may include positioning the atomizer such that the heating element is proximate the second reservoir end, the first distal arm and the second distal arm of the liquid transport element and the heater terminals are at least partially received in the cavity, the first liquid transport element end and the second liquid transport element end are proximate the first reservoir end, and the first reservoir end of the reservoir substrate is proximate the base. Inserting the atomizer through the cavity may further include inserting the first distal arm and the second distal arm of the liquid transport element in a plurality of grooves extending between the first reservoir end and the second reservoir end of the reservoir substrate at the cavity.

In some embodiments the method may additionally include inserting the atomizer through a retainer clip configured to retain the liquid transport element in contact with the heater terminals. Further, the method may include providing an electronic control component and a control component terminal, connecting the control component terminal to the base, coupling the electronic control component to the control component terminal, and inserting the electronic control component into the cavity of the reservoir substrate. Connecting the control component terminal to the base and connecting the heater terminals to the base may include inserting the control component terminal and the heater terminals to a plurality of different heights within the base. Connecting the control component terminal to the base and coupling the electronic control component to the control component terminal may be conducted before connecting the heater terminals to the base.

In some embodiments wrapping the heating element at least partially about the liquid transport element may include winding a wire about the liquid transport element to define a plurality of coils wound about the liquid transport element extending between a first wire end and a second wire end. The method may further include coupling two connector rings to the heating element at the first wire end and the second wire

end, wherein connecting the heating element to the heater terminals includes connecting the heater terminals to the connector rings. In another embodiment, connecting the heating element to the heater terminals may include connecting the heating element to the heater terminals directly. Winding the wire about the liquid transport element to define the coils may include winding the wire such that a spacing of the coils of the wire is less proximate the first wire end and the second wire end. The method may additionally include providing an external shell and a mouthpiece and coupling the external shell to the base and coupling the mouthpiece to the external shell.

BRIEF DESCRIPTION OF THE FIGURES

Having thus described the disclosure in the foregoing general terms, reference will now be made to the accompanying drawings, which are not necessarily drawn to scale, and wherein:

FIG. 1 illustrates a sectional view through a smoking article comprising a control body and a cartridge including an atomizer according to an example embodiment of the present disclosure;

FIG. 2 illustrates an exploded view of a cartridge for a smoking article comprising a base, a control component terminal, an electronic control component, an atomizer, a reservoir substrate, an external shell, and a mouthpiece according to an example embodiment of the present disclosure;

FIG. 3 illustrates an enlarged exploded view of the base and the control component terminal of the cartridge of FIG. 2;

FIG. 4 illustrates an enlarged perspective view of the base and the control component terminal of FIG. 2 in an assembled configuration;

FIG. 5 illustrates an enlarged perspective view of the base, the control component terminal, and the electronic control component of FIG. 2 in an assembled configuration;

FIG. 6 illustrates an enlarged perspective view of the atomizer of FIG. 2;

FIG. 7 illustrates an enlarged side perspective view of the base, the control component terminal, the electronic control component, and the atomizer of FIG. 2 in an assembled configuration;

FIG. 8 illustrates an enlarged bottom perspective view of the base, the control component terminal, the electronic control component, and the atomizer of FIG. 2 in an assembled configuration;

FIG. 9 illustrates a perspective view of the base, the atomizer, and the reservoir substrate of FIG. 2 in an assembled configuration;

FIG. 10 illustrates a perspective view of the base and the external shell of FIG. 2 in an assembled configuration;

FIG. 11 illustrates a perspective view of the cartridge of FIG. 2 in an assembled configuration;

FIG. 12 illustrates a first partial perspective view of the cartridge of FIG. 2 and a receptacle for a control body according to an example embodiment of the present disclosure;

FIG. 13 illustrates an opposing second partial perspective view of the cartridge of FIG. 2 and the receptacle of FIG. 12;

FIG. 14 illustrates an exploded view of a cartridge for a smoking article comprising a base, a control component terminal, an electronic control component, an atomizer, a retainer clip, a reservoir substrate, an external shell, and a mouthpiece according to an example embodiment of the present disclosure;

FIG. 15 illustrates an enlarged perspective view of the base, the control component terminal, and the heater terminals of the cartridge of FIG. 14 in an assembled configuration;

5

FIG. 16 illustrates an enlarged perspective view of the base, the control component terminal, the heater terminals, and the atomizer of the cartridge of FIG. 14 in an assembled configuration;

FIG. 17 illustrates a partial perspective view of the cartridge of FIG. 14 further comprising a flow tube according to an example embodiment of the present disclosure;

FIG. 18 illustrates an end view of the flow tube of FIG. 17;

FIG. 19 illustrates a perspective view of a truncated side of the flow tube;

FIG. 20 illustrates a perspective view of an elongated side of the flow tube;

FIG. 21 illustrates a perspective view of a liquid transport element with a wire heating element and connector rings received thereon according to an example embodiment of the present disclosure;

FIG. 22 illustrates a perspective view of an atomizer comprising the liquid transport element with the wire heating element and the connector rings received thereon of FIG. 21;

FIG. 23 illustrates a partially exploded view of an aerosol delivery device including a control body in a assembled configuration and a cartridge in an exploded configuration, the cartridge comprising a base shipping plug, a base, a control component terminal, an electronic control component, a flow tube, an atomizer, a reservoir substrate, an external shell, a label, a mouthpiece, and a mouthpiece shipping plug according to an example embodiment of the present disclosure;

FIG. 24 illustrates an enlarged perspective view of the base, the atomizer, the flow tube, and the reservoir substrate of FIG. 23 in an assembled configuration;

FIG. 25 illustrates a schematic view of a method for assembling a cartridge for a smoking article according to an example embodiment of the present disclosure;

FIG. 26 illustrates a partial perspective view of an input for production of a plurality of atomizers comprising a carrier and a plurality of heating elements coupled to connecting strips of the carrier according to an example embodiment of the present disclosure;

FIG. 27 illustrates an enlarged top view of one of the heating elements of the input of FIG. 26 in an initial planar configuration;

FIG. 28 illustrates an enlarged perspective view of one of the heating elements of the input of FIG. 26 in a bent configuration;

FIG. 29 illustrates a partial perspective view of an input for production of a plurality of atomizers comprising a carrier and a plurality of heating elements coupled to side strips of the carrier according to an example embodiment of the present disclosure;

FIG. 30 illustrates steps performed in producing atomizers from the input of FIG. 29 according to an example embodiment of the present disclosure; and

FIG. 31 illustrates a schematic view of a method of forming a plurality of atomizers according to an example embodiment of the present disclosure.

DETAILED DESCRIPTION OF PREFERRED EMBODIMENTS

The present disclosure will now be described more fully hereinafter with reference to exemplary embodiments thereof. These exemplary embodiments are described so that this disclosure will be thorough and complete, and will fully convey the scope of the disclosure to those skilled in the art. Indeed, the disclosure may be embodied in many different forms and should not be construed as limited to the embodiments set forth herein; rather, these embodiments are pro-

6

vided so that this disclosure will satisfy applicable legal requirements. As used in the specification, and in the appended claims, the singular forms “a”, “an”, “the”, include plural referents unless the context clearly dictates otherwise.

The present disclosure provides descriptions of aerosol delivery devices that use electrical energy to heat a material (preferably without combusting the material to any significant degree) to form an inhalable substance; such articles most preferably being sufficiently compact to be considered “hand-held” devices. In certain highly preferred embodiments, the aerosol delivery devices can be characterized as smoking articles. As used herein, the term “smoking article” is intended to mean an article or device that provides some or all of the sensations (e.g., inhalation and exhalation rituals, types of tastes or flavors, organoleptic effects, physical feel, use rituals, visual cues such as those provided by visible aerosol, and the like) of smoking a cigarette, cigar, or pipe, without any substantial degree of combustion of any component of that article or device. As used herein, the term “smoking article” does not necessarily mean that, in operation, the article or device produces smoke in the sense of the aerosol resulting from by-products of combustion or pyrolysis of tobacco, but rather, that the article or device yields vapors (including vapors within aerosols that can be considered to be visible aerosols that might be considered to be described as smoke-like) resulting from volatilization or vaporization of certain components of the article or device. In highly preferred embodiments, articles or devices characterized as smoking articles incorporate tobacco and/or components derived from tobacco.

Articles or devices of the present disclosure also can be characterized as being vapor-producing articles, aerosol delivery articles or medicament delivery articles. Thus, such articles or devices can be adapted so as to provide one or more substances (e.g., flavors and/or pharmaceutical active ingredients) in an inhalable form or state. For example, inhalable substances can be substantially in the form of a vapor (i.e., a substance that is in the gas phase at a temperature lower than its critical point). Alternatively, inhalable substances can be in the form of an aerosol (i.e., a suspension of fine solid particles or liquid droplets in a gas). For purposes of simplicity, the term “aerosol” as used herein is meant to include vapors, gases and aerosols of a form or type suitable for human inhalation, whether or not visible, and whether or not of a form that might be considered to be smoke-like.

In use, smoking articles of the present disclosure may be subjected to many of the physical actions employed by an individual in using a traditional type of smoking article (e.g., a cigarette, cigar or pipe that is employed by lighting and inhaling tobacco). For example, the user of a smoking article of the present disclosure can hold that article much like a traditional type of smoking article, draw on one end of that article for inhalation of aerosol produced by that article, take puffs at selected intervals of time, etc.

Smoking articles of the present disclosure generally include a number of components provided within an outer shell or body. The overall design of the outer shell or body can vary, and the format or configuration of the outer body that can define the overall size and shape of the smoking article can vary. Typically, an elongated body resembling the shape of a cigarette or cigar can be formed from a single, unitary shell; or the elongated body can be formed of two or more separable pieces. For example, a smoking article can comprise an elongated shell or body that can be substantially tubular in shape and, as such, resemble the shape of a conventional cigarette or cigar. In one embodiment, all of the components of the smoking article are contained within one

outer body or shell. Alternatively, a smoking article can comprise two or more shells that are joined and are separable. For example, a smoking article can possess at one end a control body comprising a shell containing one or more reusable components (e.g., a rechargeable battery and various electronics for controlling the operation of that article), and at the other end and removably attached thereto a shell containing a disposable portion (e.g., a disposable flavor-containing cartridge). More specific formats, configurations and arrangements of components within the single shell type of unit or within a multi-piece separable shell type of unit will be evident in light of the further disclosure provided herein. Additionally, various smoking article designs and component arrangements can be appreciated upon consideration of the commercially available electronic smoking articles, such as those representative products listed in the background art section of the present disclosure.

Smoking articles of the present disclosure most preferably comprise some combination of a power source (i.e., an electrical power source), at least one control component (e.g., means for actuating, controlling, regulating and ceasing power for heat generation, such as by controlling electrical current flow the power source to other components of the article), a heater or heat generation component (e.g., an electrical resistance heating element or component commonly referred to as an "atomizer"), and an aerosol precursor composition (e.g., commonly a liquid capable of yielding an aerosol upon application of sufficient heat, such as ingredients commonly referred to as "smoke juice," "e-liquid" and "e-juice"), and a mouthend region or tip for allowing draw upon the smoking article for aerosol inhalation (e.g., a defined air flow path through the article such that aerosol generated can be withdrawn therefrom upon draw). Exemplary formulations for aerosol precursor materials that may be used according to the present disclosure are described in U.S. Pat. Pub. No. 2013/0008457 to Zheng et al., the disclosure of which is incorporated herein by reference in its entirety.

Alignment of the components within the article can vary. In specific embodiments, the aerosol precursor composition can be located near an end of the article (e.g., within a cartridge, which in certain circumstances can be replaceable and disposable), which may be proximal to the mouth of a user so as to maximize aerosol delivery to the user. Other configurations, however, are not excluded. Generally, the heating element can be positioned sufficiently near the aerosol precursor composition so that heat from the heating element can volatilize the aerosol precursor (as well as one or more flavorants, medicaments, or the like that may likewise be provided for delivery to a user) and form an aerosol for delivery to the user. When the heating element heats the aerosol precursor composition, an aerosol is formed, released, or generated in a physical form suitable for inhalation by a consumer. It should be noted that the foregoing terms are meant to be interchangeable such that reference to release, releasing, releases, or released includes form or generate, forming or generating, forms or generates, and formed or generated. Specifically, an inhalable substance is released in the form of a vapor or aerosol or mixture thereof. Additionally, the selection of various smoking article components can be appreciated upon consideration of the commercially available electronic smoking articles, such as those representative products listed in the background art section of the present disclosure.

A smoking article incorporates a battery or other electrical power source to provide current flow sufficient to provide various functionalities to the article, such as resistive heating, powering of control systems, powering of indicators, and the like. The power source can take on various embodiments.

Preferably, the power source is able to deliver sufficient power to rapidly heat the heating member to provide for aerosol formation and power the article through use for the desired duration of time. The power source preferably is sized to fit conveniently within the article so that the article can be easily handled; and additionally, a preferred power source is of a sufficiently light weight to not detract from a desirable smoking experience.

One example embodiment of a smoking article **100** is provided in FIG. 1. As seen in the cross-section illustrated therein, the smoking article **100** can comprise a control body **102** and a cartridge **104** that can be permanently or detachably aligned in a functioning relationship. Although a threaded engagement is illustrated in FIG. 1, it is understood that further means of engagement are encompassed, such as a press-fit engagement, interference fit, a magnetic engagement, or the like.

In specific embodiments, one or both of the control body **102** and the cartridge **104** may be referred to as being disposable or as being reusable. For example, the control body may have a replaceable battery or may be rechargeable and thus may be combined with any type of recharging technology, including connection to a typical electrical outlet, connection to a car charger (i.e., cigarette lighter receptacle), and connection to a computer, such as through a USB cable.

In the exemplified embodiment, the control body **102** includes a control component **106**, a flow sensor **108**, and a battery **110**, which can be variably aligned, and can include a plurality of indicators **112** at a distal end **114** of an external shell **116**. The indicators **112** can be provided in varying numbers and can take on different shapes and can even be an opening in the body (such as for release of sound when such indicators are present).

An air intake **118** may be positioned in the external shell **116** of the control body **102**. A receptacle **120** also is included at the proximal attachment end **122** of the control body **102** and extends into a control body projection **124** to allow for ease of electrical connection with an atomizer or a component thereof, such as a resistive heating element (described below) when the cartridge **104** is attached to the control body.

The cartridge **104** includes an external shell **126** with a mouth opening **128** at a mouthend **130** thereof to allow passage of air and entrained vapor (i.e., the components of the aerosol precursor composition in an inhalable form) from the cartridge to a consumer during draw on the smoking article **100**. The smoking article **100** may be substantially rod-like or substantially tubular shaped or substantially cylindrically shaped in some embodiments.

The cartridge **104** further includes an atomizer **132** comprising a resistive heating element **134** comprising a wire coil in the illustrated embodiment and a liquid transport element **136** comprising a wick in the illustrated embodiment and configured to transport a liquid. Various embodiments of materials configured to produce heat when electrical current is applied therethrough may be employed to form the wire coil. Example materials from which the wire coil may be formed include Kanthal (FeCrAl), Nichrome, Molybdenum disilicide (MoSi₂), molybdenum silicide (MoSi), Molybdenum disilicide doped with Aluminum (Mo(Si,Al)₂), and ceramic (e.g., a positive temperature coefficient ceramic). Electrically conductive heater terminals **138** (e.g., positive and negative terminals) at the opposing ends of the heating element **134** are configured to direct current flow through the heating element and configured for attachment to the appropriate wiring or circuit (not illustrated) to form an electrical connection of the heating element with the battery **110** when the cartridge **104** is connected to the control body **102**. Spe-

cifically, a plug **140** may be positioned at a distal attachment end **142** of the cartridge **104**. When the cartridge **104** is connected to the control body **102**, the plug **140** engages the receptacle **120** to form an electrical connection such that current controllably flows from the battery **110**, through the

receptacle and plug, and to the heating element **134**. The external shell **126** of the cartridge **104** can continue across the distal attachment end **142** such that this end of the cartridge is substantially closed with the plug protruding therefrom. A reservoir may utilize a liquid transport element to transport an aerosol precursor composition to an aerosolization zone. One such example is shown in FIG. 1. As seen therein, the cartridge **104** includes a reservoir layer **144** comprising layers of nonwoven fibers formed into the shape of a tube encircling the interior of the external shell **126** of the cartridge, in this embodiment. An aerosol precursor composition is retained in the reservoir layer **144**. Liquid components, for example, can be sorptively retained by the reservoir layer **144**. The reservoir layer **144** is in fluid connection with a liquid transport element **136** (the wick in this embodiment). The liquid transport element **136** transports the aerosol precursor composition stored in the reservoir layer **144** via capillary action to an aerosolization zone **146** of the cartridge **104**. As illustrated, the liquid transport element **136** is in direct contact with the heating element **134** that is in the form of a metal wire coil in this embodiment.

In use, when a user draws on the article **100**, the heating element **134** is activated (e.g., such as via a puff sensor), and the components for the aerosol precursor composition are vaporized in the aerosolization zone **146**. Drawing upon the mouthend **130** of the article **100** causes ambient air to enter the air intake **118** and pass through the central opening in the receptacle **120** and the central opening in the plug **140**. In the cartridge **104**, the drawn air passes through an air passage **148** in an air passage tube **150** and combines with the formed vapor in the aerosolization zone **146** to form an aerosol. The aerosol is whisked away from the aerosolization zone **146**, passes through an air passage **152** in an air passage tube **154**, and out the mouth opening **128** in the mouthend **130** of the article **100**.

It is understood that a smoking article that can be manufactured according to the present disclosure can encompass a variety of combinations of components useful in forming an electronic smoking article. Reference is made for example to the smoking articles disclosed in U.S. patent application Ser. No. 13/536,438, filed Jun. 28, 2012, U.S. patent application Ser. No. 13/432,406, filed Mar. 28, 2012, U.S. patent application Ser. No. 13/602,871, filed Sep. 4, 2012, the disclosures of which are incorporated herein by reference in their entirety. Further to the above, representative heating elements and materials for use therein are described in U.S. Pat. No. 5,060,671 to Counts et al.; U.S. Pat. No. 5,093,894 to Deevi et al.; U.S. Pat. No. 5,224,498 to Deevi et al.; U.S. Pat. No. 5,228,460 to Sprinkel Jr., et al.; U.S. Pat. No. 5,322,075 to Deevi et al.; U.S. Pat. No. 5,353,813 to Deevi et al.; U.S. Pat. No. 5,468,936 to Deevi et al.; U.S. Pat. No. 5,498,850 to Das; U.S. Pat. No. 5,659,656 to Das; U.S. Pat. No. 5,498,855 to Deevi et al.; U.S. Pat. No. 5,530,225 to Hajaligol; U.S. Pat. No. 5,665,262 to Hajaligol; U.S. Pat. No. 5,573,692 to Das et al.; and U.S. Pat. No. 5,591,368 to Fleischhauer et al., the disclosures of which are incorporated herein by reference in their entireties. Further, a single-use cartridge for use with an electronic smoking article is disclosed in U.S. patent application Ser. No. 13/603,612, filed Sep. 5, 2012, which is incorporated herein by reference in its entirety.

The various components of a smoking article according to the present disclosure can be chosen from components

described in the art and commercially available. Examples of batteries that can be used according to the disclosure are described in U.S. Pat. App. Pub. No. 2010/0028766, the disclosure of which is incorporated herein by reference in its entirety.

An exemplary mechanism that can provide puff-actuation capability includes a Model 163PC01D36 silicon sensor, manufactured by the MicroSwitch division of Honeywell, Inc., Freeport, Ill. Further examples of demand-operated electrical switches that may be employed in a heating circuit according to the present disclosure are described in U.S. Pat. No. 4,735,217 to Gerth et al., which is incorporated herein by reference in its entirety. Further description of current regulating circuits and other control components, including microcontrollers that can be useful in the present smoking article, are provided in U.S. Pat. Nos. 4,922,901, 4,947,874, and 4,947,875, all to Brooks et al., U.S. Pat. No. 5,372,148 to McCafferty et al., U.S. Pat. No. 6,040,560 to Fleischhauer et al., and U.S. Pat. No. 7,040,314 to Nguyen et al., all of which are incorporated herein by reference in their entireties.

The aerosol precursor, which may also be referred to as an aerosol precursor composition or a vapor precursor composition, can comprise one or more different components. For example, the aerosol precursor can include a polyhydric alcohol (e.g., glycerin, propylene glycol, or a mixture thereof). Representative types of further aerosol precursor compositions are set forth in U.S. Pat. No. 4,793,365 to Sensabaugh, Jr. et al.; U.S. Pat. No. 5,101,839 to Jakob et al.; PCT WO 98/57556 to Biggs et al.; and Chemical and Biological Studies on New Cigarette Prototypes that Heat Instead of Burn Tobacco, R. J. Reynolds Tobacco Company Monograph (1988); the disclosures of which are incorporated herein by reference.

Still further components can be utilized in the smoking article of the present disclosure. For example, U.S. Pat. No. 5,261,424 to Sprinkel, Jr. discloses piezoelectric sensors that can be associated with the mouth-end of a device to detect user lip activity associated with taking a draw and then trigger heating; U.S. Pat. No. 5,372,148 to McCafferty et al. discloses a puff sensor for controlling energy flow into a heating load array in response to pressure drop through a mouthpiece; U.S. Pat. No. 5,967,148 to Harris et al. discloses receptacles in a smoking device that include an identifier that detects a non-uniformity in infrared transmissivity of an inserted component and a controller that executes a detection routine as the component is inserted into the receptacle; U.S. Pat. No. 6,040,560 to Fleischhauer et al. describes a defined executable power cycle with multiple differential phases; U.S. Pat. No. 5,934,289 to Watkins et al. discloses photonic-optronic components; U.S. Pat. No. 5,954,979 to Counts et al. discloses means for altering draw resistance through a smoking device; U.S. Pat. No. 6,803,545 to Blake et al. discloses specific battery configurations for use in smoking devices; U.S. Pat. No. 7,293,565 to Griffen et al. discloses various charging systems for use with smoking devices; U.S. Pat. App. Pub. No. 2009/0320863 by Fernando et al. discloses computer interfacing means for smoking devices to facilitate charging and allow computer control of the device; U.S. Pat. App. Pub. No. 2010/0163063 by Fernando et al. discloses identification systems for smoking devices; and WO 2010/003480 by Flick discloses a fluid flow sensing system indicative of a puff in an aerosol generating system; all of the foregoing disclosures being incorporated herein by reference in their entireties. Further examples of components related to electronic aerosol delivery articles and disclosing materials or components that may be used in the present article include U.S. Pat. No. 4,735,217 to Gerth et al.; U.S. Pat. No. 5,249,586 to Morgan

et al.; U.S. Pat. No. 5,666,977 to Higgins et al.; U.S. Pat. No. 6,053,176 to Adams et al.; U.S. Pat. No. 6,164,287 to White; U.S. Pat. No. 6,196,218 to Voges; U.S. Pat. No. 6,810,883 to Felter et al.; U.S. Pat. No. 6,854,461 to Nichols; U.S. Pat. No. 7,832,410 to Hon; U.S. Pat. No. 7,513,253 to Kobayashi; U.S. Pat. No. 7,896,006 to Hamano; U.S. Pat. No. 6,772,756 to Shayan; U.S. Pat. No. 8,156,944 to Hon; U.S. Pat. App. Pub. Nos. 2006/0196518, 2009/0126745, and 2009/0188490 to Hon; U.S. Pat. App. Pub. No. 2009/0272379 to Thorens et al.; U.S. Pat. App. Pub. Nos. 2009/0260641 and 2009/0260642 to Monsees et al.; U.S. Pat. App. Pub. Nos. 2008/0149118 and 2010/0024834 to Oglesby et al.; U.S. Pat. App. Pub. No. 2010/0307518 to Wang; and WO 2010/091593 to Hon. A variety of the materials disclosed by the foregoing documents may be incorporated into the present devices in various embodiments, and all of the foregoing disclosures are incorporated herein by reference in their entireties.

FIG. 2 illustrates an exploded view of an example embodiment of a cartridge **200** for a smoking article according to the present disclosure. The cartridge **200** may comprise a base **202**, a control component terminal **204**, an electronic control component **206**, an atomizer **208**, a reservoir substrate **210**, an external shell **212**, and a mouthpiece **214**. The cartridge **200** may be configured to couple to a control body to form a smoking article. Note that the various embodiments of components described above in the cited references and/or included in commercially available aerosol delivery devices may be employed in embodiments of the cartridges described here. Note further that some of these portions of the cartridge **200** are optional. In this regard, by way of example, the cartridge **200** may not include the control component terminal **204** and the electronic control component **206** in some embodiments.

FIG. 3 illustrates an enlarged exploded view of the base **202** and the control component terminal **204**. The control component terminal **204** may define a clip **216** configured to engage the electronic control component **206** and form an electrical connection therewith. Further, the control component terminal **204** may include one or more protrusions **218a**, **218b** configured to engage the base **202**, for example via interference fit, such that the control component terminal **204** is retained in engagement therewith. An end **220** of the control component terminal **204** may be configured to engage a control body, so as to establish an electrical connection therewith.

As illustrated, the base **202** may define a receptacle **222** configured to receive the control component terminal **204** therein. In this regard, as illustrated in FIG. 4, the control component terminal **204** may couple to the base **202**. For example, the control component terminal **204** may be retained in the receptacle **222** of the base **202** via interference fit, for example due to contact between the protrusions **218a**, **218b** and the base. As described below, the control component terminal **204** may extend through the base **202** to a position at which it may form an electrical connection with a control body to which the cartridge **200** connects. Further, the base **202** may define threads or protrusions **224** configured to engage the external shell **212**, as will be described below.

As illustrated in FIG. 5, the control component terminal **204** may couple to the electronic control component **206** such that an electrical connection is established therebetween. Accordingly, when the cartridge **200** is coupled to a control body, the electronic control component **206** may communicate therewith through the control component terminal **204**. The electronic control component **206** may be configured to perform one or more of a variety of functions. Further, the electronic control component **206** may be configured as purpose-specific analog and/or digital circuitry with or without a

processor, or the electronic control component may comprise hardware, software, or a combination of hardware and software. Accordingly, any or all of the functions performed by or in conjunction with the electronic control component **206** may be embodied in a computer-readable storage medium having computer-readable program code portions stored therein that, in response to execution by a processor, cause an apparatus to at least perform or direct the recited functions. In one particular instance, upon establishment of communication between the electronic control component **206** and a control body, the electronic control component may be configured to provide an authentication code or other appropriate indicia to the control body. In such instances, the control body may be configured to evaluate the authentication indicia to determine whether the cartridge **200** is authorized for use with the control body. However, the electronic control component **206** may perform various other functions. Various examples of electronic control components and functions performed thereby are described in U.S. patent application Ser. No. 13/647,000, filed Oct. 8, 2012, which is incorporated herein by reference in its entirety.

FIG. 6 illustrates an enlarged perspective view of the atomizer **208**. As illustrated, the atomizer **208** may include a liquid transport element **226**, a heating element **228**, a first heater terminal **230a** and a second heater terminal **230b** (collectively, "heater terminals **230**"). The liquid transport element **226** extends between a first liquid transport element end **232a** and a second liquid transport element end **232b** (collectively, "liquid transport element ends **232**"). The liquid transport element **226** may comprise a wick in some embodiments, as described above.

The heating element **228** extends at least partially about the liquid transport element **226** at a position between the first liquid transport element end **232a** and the second liquid transport element end **232b**. In some embodiments, the heating element **228** may comprise a wire **234** defining a plurality of coils wound about the liquid transport element **226** and extending between a first wire end **236a** and a second wire end **236b** (collectively, "wire ends **236**"), as illustrated in FIGS. 6 and 8. The wire **234** may comprise material configured to produce heat when electrical current is provided therethrough. For example, the wire **234** may comprise Kanthal (FeCrAl), Nichrome, Molybdenum disilicide (MoSi₂), molybdenum silicide (MoSi), Molybdenum disilicide doped with Aluminum (Mo(Si,Al)₂), or ceramic (e.g., a positive temperature coefficient ceramic) in some embodiments, although various other materials may be employed in other embodiments. In some embodiments the heating element **228** may be formed by winding the wire **234** about the liquid transport element **226** as described in U.S. patent application Ser. No. 13/708,381, filed Dec. 7, 2012, which is incorporated herein by reference in its entirety. However, various other embodiments of methods may be employed to form the heating element **228**, and various other embodiments of heating elements may be employed in the atomizer **208**.

The heater terminals **230** connect to the heating element **228**. In one embodiment the heater terminals **230** directly contact the wire **234** proximate the first wire end **236a** and the second wire end **236b**. Direct contact, as used herein, refers to physical contact between the wire **234** and the heater terminals **230**. However, direct contact, as used herein, also encompasses embodiments in which one or more welds **238a**, **238b** couple the wire **234** and the heater terminals **230** (see, e.g., FIGS. 6 and 8). A weld, as used herein, refers to a solder, flux, braze, or other material that is deposited in liquid or molten form and hardens to form a connection.

As further illustrated in FIG. 6, the liquid transport element 226 may be configured in a substantially U-shaped configuration. Accordingly, a first distal arm 240a and a second distal arm 240b (collectively, “distal arms 240”) of the liquid transport element 226 may respectively extend along the first and second heater terminals 230a, 230b. Further a center section 240c of the liquid transport element 226, at which the heating element 228 is positioned, may extend between the heater terminals 230. The liquid transport element 226 may be either preformed in the U-shaped configuration or bent to define this configuration.

The heater terminals 230 may define a plurality of walls 242. The walls 242 may include an inner wall 242a, and two side walls 242b, 242c. Accordingly, the distal arms 240 of the liquid transport element 226 may be surrounded on three sides by the walls 242 of the heater terminals 230. This configuration may assist in retaining the heater terminals 230 in contact with the distal arms 240 of the liquid transport element 226. Further, the heater terminals 230 may define a first tab 244a and a second tab 244b (collectively, “tabs 244”) to which the first wire end 236a and the second wire end 236b may be welded or otherwise connected. The heater terminals 230 may also include protrusions 246a, 246b configured to engage the base 202, for example via interference fit, such that the atomizer 208 is retained in engagement therewith. Ends 248a, 248b of the heater terminals 230 may be configured to engage a control body, so as to establish an electrical connection therewith.

As illustrated in FIG. 7, the heater terminals 230 may couple to the base 202 in addition to the heating element 228. Accordingly, the atomizer 208 may be connected to the base 202 via the heater terminals 230. The electronic control component 206 may be received between the heater terminals 230 and the liquid transport element ends 232. This configuration may allow the heater terminals 230 to provide support to the electronic control component 206, for example by contact therewith, such that the electronic control component is securely retained in place. However, a gap 250 may be provided between the electronic control component 206 and the heating element 228. The gap 250 may reduce the amount of heat transferred to the electronic control component 206 from the heating element 228, for example by preventing direct conduction therebetween. Accordingly, the risk of damage to the electronic control component 206 from excessive heat received from the heating element 228 may be reduced.

FIG. 8 illustrates an alternative perspective view of the base 202, the control component terminal 204, the electronic control component 206, and the atomizer 208 after they are coupled to one another. In particular, FIG. 8 illustrates a view of a connector end 252 of the base 202. As illustrated, a central opening 254 may be defined in the base 202. The central opening 254 may be configured to receive airflow therethrough from a control body and direct the airflow toward the heating element 228 of the atomizer 208.

Further, the end 220 of the control component terminal 204 and the ends 248a, 248b of the heater terminals 230 may be exposed at the connector end 252 of the base 202. The end 220 of the control component terminal 204 and the ends 248a, 248b of the heater terminals 230 may be located at differing positions within the base 202 such that they make connections with components at different locations within the control body, and avoid unintended contact therebetween. In this regard, the end 220 of the control component terminal 204 and the ends 248a, 248b of the heater terminals 230 may be located at differing radial distances from the central opening 254. In the illustrated embodiment, the end 220 of the control component terminal 204 is located closest to the central open-

ing 254, the first end 248a of the first heater terminal 230a is located farthest from the central opening, and the second end 248b of the second heater terminal 230b is located at a radial distance therebetween. Further, the end 220 of the control component terminal 204 and the ends 248a, 248b of the heater terminals 230 may extend to a plurality of different depths within the base 202. In the illustrated embodiment, the end 220 of the control component terminal 204 extends through the base 202 to a greatest depth, the first end 248a of the first heater terminal 230a extends through the base to the smallest depth, and the second end 248b of the second heater terminal 230b extends through the base to a depth therebetween.

FIG. 9 illustrates the assembly of FIGS. 7 and 8 after the reservoir substrate 210 is coupled thereto. The reservoir substrate 210 may be configured to hold an aerosol precursor composition. The reservoir substrate 210 may define a cavity 256 extending therethrough from a first reservoir end 258a to a second reservoir end 258b, wherein the first reservoir end is positioned proximate the base 202. In this regard, the reservoir substrate 210 may define a hollow tubular configuration. Note that although generally described herein as defining a hollow tubular configuration, the reservoir substrate 210 may define other shapes and configurations in other embodiments. The aerosol precursor composition may be retained within the material defining the reservoir substrate 210 itself, as opposed to within the cavity 256. This configuration may allow for airflow through the base, into and through the cavity 256, and past the heating element 228.

The reservoir substrate 210 can comprise various different materials and can be formed in a variety of different manners. In one embodiment the reservoir substrate 210 can be formed from a plurality of combined layers that can be concentric or overlapping. For example, the reservoir substrate 210 can be a continuous sheet of a material that is rolled to form the hollow tubular configuration. In other embodiments, the reservoir substrate 210 can be substantially a unitary component. For example, the reservoir substrate 210 can be shaped or molded so as to be a singular preformed element in the form of a substantially hollow tube, which may be substantially continuous in composition across the length and thickness thereof.

The reservoir substrate 210 can be formed from a material that is rigid or semi-rigid in some embodiments, while retaining the ability to store a liquid product such as, for example, an aerosol precursor composition. In certain embodiments, the material of the reservoir substrate 210 can be absorbent, adsorbent, or otherwise porous so as to provide the ability to retain the aerosol precursor composition. As such, the aerosol precursor composition can be characterized as being coated on, adsorbed by, or absorbed in the material of the reservoir substrate 210. The reservoir substrate 210 can be positioned within the cartridge 200 such that the reservoir substrate is in contact with the liquid transport element 226. More particularly, the reservoir substrate 210 can be manufactured from any material suitable for retaining the aerosol precursor composition (e.g., through absorption, adsorption, or the like) and allowing wicking away of the precursor composition for transport to the heating element 228.

The material of the reservoir substrate 210 may be suitable for forming and maintaining an appropriate shape. The material of the reservoir substrate 210 can be heat resistant so as to retain its structural integrity and avoid degradation at least at a temperature proximal to the heating temperature provided by the heating element 228. However, the reservoir substrate 210 need not be heat resistant to the full temperature produced by the heating element 228 due to the reservoir substrate

being out of contact therewith. The size and strength of the reservoir substrate **210** may vary according to the features and requirements of the cartridge **200**. In particular embodiments, the reservoir substrate **210** can be manufactured from a material suitable for a high-speed, automated manufacturing process. Such processes may reduce manufacturing costs compared to traditional woven or non-woven fiber mats. According to one embodiment, the reservoir can be manufactured from a cellulose acetate tow which can be processed to form a hollow acetate tube.

In certain embodiments, the reservoir substrate **210** can be provided in a form such that at least part of the cavity **256** is shaped and dimensioned to accommodate one or more other components of the cartridge **200**. In some embodiments, the term “shaped and dimensioned” can indicate that a wall of the reservoir substrate **210** at the cavity **256** includes one or more indentations or protrusions that cause the interior of the reservoir substrate to have a shape that is other than substantially smooth and continuous. In other embodiments, the hollow nature of the reservoir substrate **210** can be sufficient to allow for accommodation of further components of the cartridge **200** without the need for formation of cavities or protrusions. Thus, the cartridge **200** can be particularly beneficial in that the reservoir substrate **210** can be pre-formed and can have a hollow interior defining the cavity **256** with a wall that is shaped and dimensioned to accommodate a further component of the cartridge in a mating arrangement. This particularly can facilitate ease of assembly of the cartridge **200** and can maximize the volume of the reservoir substrate **200** while also providing sufficient space for aerosol formation.

In the illustrated embodiment, the cavity **256** extending through the reservoir substrate **210** is shaped and dimensioned to accommodate at least a portion of the atomizer **208**. Specifically, the reservoir substrate **210** includes two diametrically opposed grooves **260a**, **260b** (collectively, “grooves **260**”) at the cavity **256**. As illustrated, the grooves **260** may extend substantially the entire length of the reservoir substrate **210** from the first end **258a** to the second end **258b** thereof. In light of the reservoir substrate **210** defining the cavity **256** therethrough, the atomizer **208** can be easily positioned interior to the reservoir substrate during assembly of the smoking article. Likewise, since the cavity **256** is shaped and dimensioned to mate with the atomizer **208**, the combination can be easily assembled, and the atomizer can snugly mate with the reservoir substrate **210** while simultaneously placing the liquid transport element **226** in fluid connection with the reservoir substrate.

In this regard, the grooves **260** may be configured to receive the liquid transport element **226** at least partially therein. More particularly, the distal arms **240** of the liquid transport element **226** may be received in the grooves **260**. Thus, the liquid transport element **226** may extend substantially entirely through the reservoir substrate **210** such that the liquid transport element ends **232** are positioned proximate the first reservoir end **258a**. Further, the heater terminals **230** may extend through the cavity **256** through the reservoir substrate **210**. In some embodiments the heater terminals **230** may be partially or fully received in the grooves **260**. Additionally, the electronic control component **206** may be at least partially received in the cavity **256** through the reservoir substrate **210**.

By adapting the cavity **256** of the reservoir substrate **210** to accommodate the atomizer **208**, and/or various other components of the cartridge **200**, available open space in the cartridge can be fully maximized by extending the reservoir substrate into the previously open spaces. As a result, the overall size and capacity of the reservoir substrate **210** can be

increased in comparison to traditional woven or non-woven fiber mats that are typically utilized in electronic smoking articles. The increased capacity allows the reservoir substrate **210** to hold an increased amount of the aerosol precursor composition which may, in turn, result in longer use and enjoyment of the cartridge **200** by the end user.

As illustrated in FIG. 9, the atomizer **208** may extend through the cavity **256** of the reservoir substrate **210** such that the heating element **228** is positioned proximate the second reservoir end **258b**. More particularly, the atomizer **208** may extend completely through the cavity **256** such that the heating element **228** is positioned past the second reservoir end **258b**. This embodiment may reduce the heat directly applied by the heating element **228** to the reservoir substrate **210** such that the amount of the aerosol precursor composition vaporized by the heating element is controlled in part by the flow of the aerosol precursor composition through the liquid transport element **226** to the heating element. Accordingly, the amount of aerosol precursor composition vaporized may be more precisely controlled. However, in other embodiments, it is not necessary for the atomizer to extend beyond the second reservoir end, and the atomizer can be positioned relative to the reservoir substrate such that the heating element is received within the cavity of the reservoir substrate.

The aerosol precursor composition may comprise a variety of components including, by way of example, glycerin, nicotine, tobacco, tobacco extract, and/or flavorants. Various components that may be included in the aerosol precursor composition are described in U.S. Pat. No. 7,726,320 to Robinson et al., which is incorporated herein by reference. In some embodiments the aerosol precursor composition may additionally include an effervescent material. The effervescence material may be configured to effervesce under certain circumstances such as when combined with another material.

However, in another embodiment the effervescent material may be configured to effervesce (or otherwise produce bubbles) when exposed to heat. In this regard, the effervescent material may be configured to effervesce at a temperature at, or preferably below, a vaporization temperature of the aerosol precursor composition. By effervescing at, or preferably below, a temperature at which the aerosol precursor vaporizes, the air bubbles formed thereby may force the other components of the aerosol precursor composition to the surface of the liquid transport element **226**. Accordingly, when current is applied through the heating element **228**, the aerosol precursor component may be forced to the exterior of the liquid transport element **226**, and then the aerosol precursor component may be vaporized more readily due to more immediate and direct contact with the heat produced by the heating element. Thus, the amount of electric power required to vaporize the aerosol precursor component may be reduced by employing an effervescent material as described above. Embodiments of effervescent materials are described, by way of example, in U.S. Pat. App. Pub. No. 2012/0055494 to Hunt et al., which is incorporated herein by reference. Further, the use of effervescent materials is described, for example, in U.S. Pat. No. 4,639,368 to Niazi et al.; U.S. Pat. No. 5,178,878 to Wehling et al.; U.S. Pat. No. 5,223,264 to Wehling et al.; U.S. Pat. No. 6,974,590 to Pather et al.; and U.S. Pat. No. 7,381,667 to Bergquist et al., as well as US Pat. Pub. Nos. 2006/0191548 to Strickland et al.; 2009/0025741 to Crawford et al.; 2010/0018539 to Brinkley et al.; and 2010/0170522 to Sun et al.; and PCT WO 97/06786 to Johnson et al., all of which are incorporated by reference herein.

The reservoir substrate **210** includes an exterior surface **262** that can be substantially shaped and adapted to conform to an interior surface **264** of the external shell **212**. In this

17

regard, the external shell **212** may define a tubular shape with a cavity **266** therethrough sized to receive the reservoir substrate **210**. For example, an inner radius of the external shell **212** may substantially correspond to, or may be slightly larger than, an outer radius of the reservoir substrate **210**. Accordingly, the external shell **212** may be received over the reservoir substrate **210** and coupled to the base **202**, as illustrated in FIG. **10**. In this regard, one or more indentations **268** may engage the threads or protrusions **224** on the base **202** such that coupling is retained therebetween.

As illustrated in FIG. **11**, the external shell **212** may couple to the mouthpiece **214** such that the cavity **266** defined by the external shell is at least partially enclosed. More particularly, in one embodiment one or more indentations **270** may engage threads or protrusions **272** on the mouthpiece **214** (see, e.g., FIG. **2**) such that coupling therebetween is retained. The mouthpiece **214** defines one or more openings **274** through which air mixed with aerosol produced by the atomizer **208** may be directed when a user draws on the mouthpiece, as described in accordance with the above-noted example embodiments of smoking articles.

FIGS. **12** and **13** illustrate a coupler or receptacle **300** that may be included in a control body configured to engage the cartridge **200** and the various other embodiments of cartridges described below. As illustrated, the receptacle **300** may comprise protrusions or threads **302** that are configured to engage an external shell of the control body such that a mechanical connection is formed therebetween. The receptacle **300** may define an outer surface **304** configured to mate with an internal surface **276** of the base **202**. In one embodiment the internal surface **276** of the base **202** may define a radius that is substantially equal to, or slightly greater than, a radius of the outer surface **304** of the receptacle **300**. Further, the receptacle **300** may define one or more protrusions **306** at the outer surface **304** configured to engage one or more recesses **278** defined at the inner surface **276** of the base **202**. However, various other embodiments of structures, shapes, and components may be employed to couple the base **202** to the receptacle **300**. In some embodiments the connection between the base **202** and the receptacle **300** of the control body may be substantially permanent, whereas in other embodiments the connection therebetween may be releasable such that, for example, the control body may be reused with one or more additional cartridges.

The receptacle **300** may further comprise a plurality of electrical contacts **308a-c** respectively configured to contact the end **220** of the control component terminal **204** and the ends **248a**, **248b** of the heater terminals **230**. The electrical contacts **308a** may be positioned at differing radial distances from a central opening **310** through the receptacle **300** and positioned at differing depths within the receptacle **300**. The depth and radius of each of the electrical contacts **308a-c** is configured such that the end **220** of the control component terminal **204** and the ends **248a**, **248b** of the heater terminals **230** respectively come into contact therewith when the base **202** and the receptacle **300** are joined together to establish an electrical connection therebetween. More particularly, in the illustrated embodiment, a first electrical contact **308a** defines the smallest diameter, a third electrical contact **308c** defines the greatest diameter, and a second electrical contact **308b** defines a diameter therebetween. Further, the electrical contacts **308a-c** are located at differing depths within the receptacle **300** relative to a connector end thereof. In the illustrated embodiment, the first electrical contact **308a** is located at a greatest depth, the third electrical contact **308c** is located at the smallest depth, and the second electrical contact **308b** is located at a depth therebetween. Accordingly, the first elec-

18

trical contact **308a** may be configured to contact the end **220** of the control component terminal **204**, the second electrical contact **308b** may be configured to contact the second end **248b** of the second heater terminal **230b**, and the first end **248a** of the first heater terminal **230a** may be configured to contact the third electrical contact **308c**.

In the illustrated embodiment the electrical contacts **308a-c** comprise circular metal bands of varying radii positioned at differing depths within the receptacle **300** as described above. In one embodiment the bands may comprise continuous round rings. In another embodiment, the bands may comprise a sheet of metal material that is wound into the circular configuration and defines a joint where the ends thereof meet. In some embodiments the joint between the ends of each band of metal material may be configured at opposing non-perpendicular angles relative to a longitudinal length of the metal material defining the bands. Thereby, the ends of the band may meet at a joint that does not extend parallel to a central axis extending through the receptacle **300**. This configuration may be preferable in that it avoids creating a joint extending parallel to the central axis through the receptacle, which could form a poor connection with an end of one of the heater terminals or the control component terminal when in contact therewith. Each of the bands defines a major contact surface facing radially inwardly toward the central axis of the receptacle **300**. The bands defining the electrical contacts **308a-c** are separated from one another by stepped surfaces of the body of the receptacle, which may be oriented perpendicularly to the radially facing major surfaces of the electrical contacts.

When the electrical contacts **308a-c** comprise circular bands and the end **220** of the control component terminal **204** and the ends **248a**, **248b** of the heater terminals **230** extend to corresponding depths and radii within the base **202**, electrical connections between the base and the receptacle **300** may be established regardless of the rotational orientation of the base with respect to the receptacle. Accordingly, connection between the base **202** of the cartridge **200** and the receptacle **300** of the control body may be facilitated. The electrical contacts **308a-c** may be respectively coupled to a plurality of control body terminals **312a-c** that connect to a plurality of components within the control body such as a battery and a controller therefor.

Further, when the base **202** of the cartridge **200** and the receptacle **300** of the control body are coupled together, a fluid connection may also be established. In this regard, the receptacle **300** may define a fluid pathway configured to receive air from an ambient environment and direct the air to the cartridge **200** when a user draws thereon. More particularly, in one embodiment the receptacle **300** may define a rim **314** with a radially extending notch **316** defined therein. Further a longitudinally extending recessed slot **318** may extend from the notch **316** to an opening **320**. The opening **320** may define a cutout or a hole through a portion of the receptacle in some embodiments. Thus, when the receptacle **300** is engaged with the end of an external shell or body of a corresponding control body, the fluid pathway through the notch **316**, the slot **318**, and the opening **320** may remain open. Air drawn through this path may then be directed through the central opening **310** of the receptacle **300** and the central opening **254** of the base **202** when the receptacle and the base are connected to one another. Accordingly, air may be directed from the control body through the cartridge **200** in the manner described above when a user draws on the mouthpiece **214** of the cartridge.

Accordingly, the above-described cartridge **200** may provide benefits in terms of ease of assembly and ease of attach-

ment to the receptacle 300 of a control body. In particular, with respect to the cartridge 200, assembly thereof may be simplified in that the components thereof may be axially assembled. More specifically, the components of the cartridge 200 may be assembled in the order illustrated in FIG. 2 in some embodiments. Thus, for example, the control component terminal 204 may be coupled to the base 202, the electronic control component 206 may be coupled to the control component terminal, the atomizer 208 may be coupled to the base, the reservoir substrate 210 may be coupled to the atomizer, the external shell 212 may be coupled to the base, and the mouthpiece 214 may be coupled to the external shell, in that order. Although this order of assembly may facilitate assembly of the cartridge 200, the components thereof may be assembled in differing orders in other embodiments.

An alternate embodiment of a cartridge 400 for a smoking article is illustrated in FIG. 14. The cartridge 400 may be substantially similar to the above-described embodiment of a cartridge 200 illustrated in FIG. 2. Accordingly, only differences with respect to the above-described embodiment of a cartridge 200 will be highlighted.

In this regard, the cartridge 400 may comprise a base 402, a control component terminal 404, an electronic control component 406, an atomizer 408, a reservoir substrate 410, an external shell 412, and a mouthpiece 414. The cartridge 400 may be configured to couple to a control body to form a smoking article. Accordingly, the cartridge 400 may include embodiments of each of the components described above with respect to the embodiment of the cartridge 200 illustrated in FIG. 2.

However, as illustrated in FIG. 14, the electronic control component 406 may comprise two portions 406a, 406b. A first portion 406a of the electronic control component 406 may include hardware and/or software configured to perform one or more functions, whereas the second portion 406b of the electronic control component may provide structural support thereto. Accordingly, the electronic control component 406 may be provided in two-piece form in some embodiments. This form may allow for substitution of the first portion 406a, as may be desirable to change the functionality of the electronic control component 406, while still employing the same second portion 406b for structural support.

The atomizer 408 may also differ in one or more aspects. In this regard, as illustrated in FIG. 15, the shape of the first heater terminal 430a and the second heater terminal (collectively, "heater terminals 430") may differ in that the first tab 444a and the second tab 444b (collectively, "tabs 444") may be positioned at the end of the heater terminals distal to the base 402 and extend therefrom. In this regard, as illustrated in FIG. 16, the atomizer 408 may comprise a liquid transport element 426 and a heating element 428. The heating element 428 may comprise a wire 434 defining a plurality of coils wound about the liquid transport element 426 and extending between a first wire end 436a and a second wire end 436b (collectively, "wire ends 436"). The tabs 444 may be configured to contact the wire ends 436 such that an electrical connection is established therebetween. In this regard, the tabs 444 may be configured to be positioned adjacent to the heating element 428 such that tabs contact one or more coils of the wire 434.

In one embodiment, as illustrated in FIG. 16, the spacing of the coils (i.e. the distance therebetween) may be less proximate the wire ends 436 than proximate a center of the heating element 428. For example, in one embodiment the coils of the heating element 428 may touch one another at the wire ends 436, whereas the coils may be spaced apart such that there is

not contact therebetween between the wire ends. By decreasing the spacing between the coils of the wire 434 at the wire ends 436, more coils may contact the tabs 444, such that an improved electrical connection between the heating element 428 and the heater terminals 430 may be established. Although not illustrated, a weld may optionally be provided to secure the connection between the tabs 444 and the wire ends 436.

As illustrated in FIG. 14, the cartridge 400 may also include a retainer clip 480 in some embodiments. The retainer clip 480 may be configured to surround the atomizer 408 and retain the liquid transport element 426 in contact with the heater terminals 430. More specifically, a first distal arm 440a and a second distal arm 440b (collectively, "distal arms 440") of the liquid transport element 426 may be held in place against the heater terminals 430 by the retainer clip 480. The retainer clip 480 may define a plurality of inwardly extending bendable tabs. In some embodiments, as illustrated, the bendable tabs may include pre-bent tabs 482a, 482b configured to allow the distal arms 440 of the liquid transport element 426 to be received therethrough. After assembly of the cartridge 400, the retainer ring 480 may be positioned between the base 402 and the reservoir substrate 410.

Another difference between the cartridge 200 illustrated in FIG. 2 and the cartridge 400 illustrated in FIG. 14 is that in the embodiment the cartridge 400 illustrated in FIG. 14, the liquid transport element 426 and the heating element 428 may not be coupled to the heater terminals 430 until after the heater terminals are coupled to the base 402. In contrast, in the embodiment of the cartridge 200 illustrated in FIG. 2, the heater terminals 230 may be coupled to the liquid transport element 226 and the heating element 228 prior to coupling the atomizer 208, as an assembled unit, to the base 202. Coupling the assembled atomizer 208 to the base 202 may provide benefits in terms of assembly efficiency, whereas coupling the heater terminals 430 to the base 402 prior to coupling the liquid transport element 426 and the heating element 428 thereto may provide benefits in terms of use of the base as a structural member to hold the heater terminals in place during assembly, which may facilitate production of the heater terminals. Accordingly, both embodiments of assembly methods and related structures may provide benefits.

As illustrated in FIGS. 17-20, in some embodiments the cartridge may additionally include a flow tube 484. In some embodiments the flow tube 484 may comprise a ceramic material. For example, the flow tube 484 may comprise 96.5% aluminum trioxide in one embodiment. However, the flow tube 484 may be formed from various other materials in other embodiments.

As illustrated in FIG. 17, the flow tube 484 may be positioned between, and held in place by, the terminals 430. More particularly, as illustrated in FIG. 18, the flow tube 484 may define first 486a and second 486b opposing grooves (collectively, "grooves 486"). The grooves 486 may be sized and shaped to respectively receive one of the terminals 430 therein. In this regard, in some embodiments the flow tube 484 may define a generally round outer perimeter, with the exception of the grooves 486. Thus, the flow tube 484 may be received inside the cavity defined through the reservoir substrate 410. Accordingly, the flow tube 484 may additionally or alternatively be held in place by the reservoir substrate 410.

The flow tube 484 may further comprise a cutout 488 configured to receive the top of an electronic control component 406' therein. Optional differences with respect to the electronic control component 406' and the previously described embodiments of electronic control components are described below. By receiving the top of the electronic control

component **406'** in the cutout **488**, the flow tube **484** may be at least partially coupled thereto. In this regard, during assembly of the cartridge, in one embodiment the flow tube **484** may be attached to the electronic control component **406'** via reception of the top of the electronic control component in the cutout **488** prior to coupling the atomizer **408** to the base. However, in another embodiment the flow tube **484** may be coupled to the atomizer **408** via reception of the terminals **430** in the grooves **486** such that the cutout **488** engages the electronic control component **406'** at the same time that the atomizer is coupled to the base **402**.

The flow tube **484** may be configured to direct a flow of air received from a central opening **454** (see, FIG. **14**) in the base **402** to the heating element **428** of the atomizer **408**. More particularly, as illustrated in FIG. **18**, the flow tube **484** may define a through hole **490** configured to receive air from the central opening **454** in the base **402** and direct it to the heating element **428**. The electronic control component **406'** may substantially align with a center of the through hole **490** such that air directed through the central opening **454** in the base **402** is directed around both sides of the electronic control component and then converges in the through hole **490**. However, in other embodiments the central opening **454** in the base **402** may be configured to direct flow to only one side of the electronic component **406'**. In this regard, in one embodiment the electronic control component **406'** may define a substantially smooth surface on one side, and the flow of air from the central opening **454** in the base **402** may be directed to only the smooth side of the electronic control component. However, various other embodiments of electronic control components may be employed.

In the illustrated embodiment, the flow tube **484** defines a truncated side **492a** (see, e.g., FIG. **19**) and an elongated side **492b** (see, e.g., FIG. **20**). The elongated side **492b** may define a flow channel **494** (see, e.g., FIG. **18**) with a substantially constant area between the flow tube **484** and the electronic control component **406'**. In some embodiments the electronic control component **406'** may define the substantially smooth surface on the side adjacent to the elongated side **492b** of the flow tube **484**, as described above. Thus, the flow channel **494** may be substantially free of interference, which may improve flow to the heating element **428**.

In contrast, the truncated side **492a** of the flow tube **484** may be provided in order to complete the substantially round outer perimeter of the flow tube such that it may be retained in place in the reservoir substrate **410** and provide material through which the through hole **490** is defined. The flow tube **484** may be truncated on this side **492a** in order to allow for space for components extending from the electronic control component **406'**. However, depending on the particular size and shape of the electronic control component, the tubular reservoir substrate may be elongated on both sides such that the flow tube substantially surrounds the electronic control component and flow channels are defined on both sides thereof.

Regardless of the particular flow patterns around the electronic control component **406'**, the through hole **490** may receive all of the flow of air directed through the central opening **454** in the base **402**. Accordingly, the size of the through hole **490** may be selected to define a desired velocity of air directed to the heating element **428**. Accordingly, a desired amount of aerosol may be delivered to the air as it passes the heating element **428**. For example, the through hole **490** may taper from a relatively larger diameter to a relatively smaller diameter proximate the heating element **428**. However, in other embodiments the through hole **490** may define a substantially constant diameter.

FIG. **21** illustrates an additional embodiment of an atomizer **508**. The atomizer **508** may be substantially similar to the embodiments of atomizers **208**, **408** described above. Accordingly, features of the atomizer **508** that are substantially similar to the previously described embodiments will not be discussed. However, the heating atomizer **508** may differ in that it may further comprise a first connector ring **584a** and a second connector ring **584b** (collectively, "connector rings **584**"). The connector rings **584** may surround a heating element **528**. In this regard, as described above, the heating element **528** may comprise a wire **534** defining a plurality of coils wound about a liquid transport element **526** and extending between a first wire end **536a** and a second wire end **536b** (collectively, "wire ends **536**"). The connector rings **584** may surround the heating element **528** at the wire ends **536**.

A first heater terminal **530a** and a second heater terminal **530b** (collectively, "heater terminals **530**") may engage the connector rings **584**. Accordingly, an electrical connection may be established therebetween. More particularly, as illustrated in FIG. **22**, the connector rings **584** may be coupled to the wire ends **536** prior to coupling the heating element **528** and the liquid transport element **526** to the heater terminals **530**. Then, the connector rings **584** may be respectively received in a first clip **586a** and a second clip **586b** (collectively, "clips **586**"), which may retain the connectors therein via interference fit. Accordingly, a relatively secure mechanical and electrical connection may be established between the heating element **528** and the heater terminals **530**. In this regard, a weld may not be required to connect the heating element **528** to the heater terminals **530**. However, a weld may be optionally included in some embodiments.

Note that the above-described atomizers and variations thereof may be employed in a variety of embodiments of cartridges for aerosol delivery devices. In this regard, FIG. **23** illustrates a partially exploded view of an aerosol delivery device **600** including a control body **700**, which is illustrated in an assembled configuration, and a cartridge **800**, which is illustrated in an exploded configuration. The control body **700** may include various components as described above. For example, the control body **700** may include an outer tube **702** and a receptacle or coupler **704** and an end cap **706** coupled to opposing ends of the outer tube. Various internal components inside the outer tube **702** may include, by way of example, a flow sensor, a control component, and an electrical power source (e.g., a battery), and a light emitting diode (LED) element. However, the control body **700** may include additional or alternative components in other embodiments.

As illustrated, the cartridge **800** may comprise a base shipping plug **802**, a base **804**, a control component terminal **806**, an electronic control component **808**, a flow tube **810**, an atomizer **812**, a reservoir substrate **814**, an external shell **816**, a label **818**, a mouthpiece **820**, and a mouthpiece shipping plug **822** according to an example embodiment of the present disclosure. Many of these components are substantially similar to the components of the cartridges described above. Accordingly, only differences with respect to the previously-described embodiments of cartridges will be described below.

In this regard, in one embodiment the electronic control component **808** may comprise a single-piece printed circuit board assembly. The electronic control component **808** may include a ceramic substrate, which may comprise about 96% alumina ceramic in one embodiment. This material is inorganic, non-reactive, non-degrading, and non-porous. Use of such a ceramic material may be preferable in that it may define a robust, dimensionally-stable part without requiring a separate supporting structure. Further, such a ceramic mate-

rial may allow for adhesion of a coating thereto. For example, a component side of the electronic control component **808** may comprise a chloro-substituted poly(para-xylylene) commercially available as Parylene C from Specialty Coating Systems, Inc., or any other coating or other sealant/barrier coating configured to protect components of the circuit board from liquid and moisture. The sealant/barrier coating may also provide the electronic control component **808** with a decreased coefficient of friction, which may facilitate an axial assembly process of the cartridge **800**.

Further, the mouthpiece shipping plug **822** is configured to engage openings in the mouthpiece **820** prior to use of the cartridge **800** in order to prevent entry of contaminants through the openings in the mouthpiece. Similarly, the base shipping plug **802** is configured to couple to an inner periphery of the base **804** to protect the base from damage or contamination during transport and storage. Further, the label **818** may serve as an exterior member providing the cartridge **800** with identifying information.

FIG. **24** illustrates a perspective view of the cartridge **800** in a partially assembled configuration. More particularly, FIG. **24** illustrates components of the cartridge **800** in a partially assembled configuration corresponding to the configuration illustrated in FIG. **9**. Thus, briefly, FIG. **24** illustrates a configuration in which the control component terminal **806** has been coupled to the base **804**, the electronic control component **808** has been coupled to the electronic control component terminal, a first heater terminal **834a** and a second heater terminal **834b** (collectively, "heater terminals **834**") has been coupled to the base, the flow tube **810** is received between the heater terminals, a heating element **840** is coupled to a liquid transport element **838**, the heating element is coupled to first and second tabs **836a**, **836b** (collectively, "tabs **836**") of the heater terminals to complete the atomizer **812**, and the reservoir substrate **814** is received around the atomizer.

The reservoir substrate **814** may define a cavity **852** extending therethrough from a first reservoir end **854a** to a second reservoir end **854b** (collectively, "reservoir ends **854**"), wherein the first reservoir end is positioned proximate the base **804**. In this regard, the reservoir substrate **814** may define a hollow tubular configuration. The reservoir substrate **814** can comprise one or more of various materials and can be formed in a variety of different manners. In one embodiment the reservoir substrate **814** can be formed from a plurality of combined layers that can be concentric or overlapping. For example, the reservoir substrate **814** can be a continuous sheet of a material that is rolled such that the ends thereof meet along a joint **856** to form the hollow tubular configuration, or multiple layers of the material may be wrapped thereabout. Thus, the reservoir substrate **814** may conform to the shape of the components received in the cavity **852** such as the atomizer **812**.

As illustrated in FIGS. **23** and **24**, in some embodiments the heating element **840** may comprise a wire wound about the liquid transport element **838** and extending along substantially the entirety of the length of the liquid transport element **838**. As further illustrated, in one embodiment the heating element **840** may define a variable coil spacing. The spacing of the coils may be the smallest proximate the tabs **836**, greatest at the distal ends of the liquid transport element **838**, and in between the spacing of the coils at the tabs and the distal ends between the heater terminals **834**. By decreasing the spacing between the coils of the heating element **840** proximate the tabs **836**, contact therebetween may be improved. For example, a laser may be directed at a back side of the tabs, opposite from the heating element **840**, which may

weld the heating element to the tabs in order to provide for a connection therebetween. The spacing of the coils of the heating element **840** between the tabs **836** may be selected to define a desired resistance and/or produce a desired amount of heat. Further, the spacing of the coils of the heating element **840** at the distal ends of the liquid transport element **838** may be relatively large in order to decrease material costs associated with production of the heating element.

The cartridge **800** may additionally include the flow tube **810**, which may be substantially similar to the above-described flow tube **484**. Thus, as illustrated in FIG. **24**, the flow tube **810** may be positioned between, and held in place by, the terminals **834**. More particularly, the flow tube **810** may define first **858a** and second **858b** opposing grooves (collectively, "grooves **858**"). The grooves **858** may be sized and shaped to respectively receive one of the terminals **834** therein. In this regard, in some embodiments the flow tube **810** may define a generally round outer perimeter, with the exception of the grooves **858**. Thus, the flow tube **810** may be received inside the cavity **852** defined through the reservoir substrate **814**. Accordingly, the flow tube **810** may additionally or alternatively be held in place by the reservoir substrate **814**. The flow tube **810** may also be held in place via contact with the electronic control component **808** in some embodiments.

The flow tube **810** may be configured to direct a flow of air received from the base **804** to the heating element **840** of the atomizer **812**. More particularly, as illustrated in FIG. **24**, the flow tube **810** may define a through hole **860** extending at least partially along the length of the flow tube at a center thereof and configured to receive air from the base **804** and direct it to the heating element **840**. Accordingly, the size of the through hole **860** may be selected to define a desired velocity of air directed to the heating element **840**. Accordingly, a desired amount of aerosol may be delivered to the air as the air passes the heating element **840**. For example, the through hole **860** may taper from a relatively larger diameter to a relatively smaller diameter proximate the heating element **840**. However, in other embodiments the through hole **860** may define a substantially constant or increasing diameter.

In some embodiments the flow tube **810** may comprise a ceramic material. For example, the flow tube **810** may comprise 96.5% aluminum tri oxide in one embodiment. This material may provide heat resistance which may be desirable due to proximity to the heating element **840**. However, the flow tube **810** may be formed from various other materials in other embodiments.

The reservoir substrate **814** includes an exterior surface **862** that can be substantially shaped and adapted to conform to an interior surface of the external shell **816** (see, FIG. **23**). Accordingly, the external shell **816** may be received over the reservoir substrate **814** and coupled to the base **804**. In a fully assembled configuration the cartridge may appear substantially similar to the cartridge **200** illustrated in FIG. **11** with the base shipping plug, the mouthpiece shipping plug, and the label coupled thereto.

A method for assembling a cartridge for a smoking article is also provided. As illustrated in FIG. **25**, the method may include providing a base defining a connector end configured to engage a control body, an atomizer, and a reservoir substrate configured to hold an aerosol precursor composition and defining a cavity extending therethrough from a first reservoir end to a second reservoir end at operation **900**. Further, the method may include connecting the atomizer to the base at operation **902**. Additionally, the method may include inserting the atomizer through the cavity through the reservoir substrate at operation **904**.

25

In some embodiments the method may further comprise assembling the atomizer at operation **906**. Assembling the atomizer at operation **906** may comprise providing a plurality of heater terminals, a liquid transport element extending between a first liquid transport element end and a second liquid transport element end, and a heating element. Further, assembling the atomizer at operation **906** may include wrapping the heating element at least partially about the liquid transport element and connecting the heating element to the heater terminals such that the heating element extends therebetween and a first distal arm of the liquid transport element and a second distal arm of the liquid transport element extend along the heater terminals. In some embodiments wrapping the heating element at least partially about the liquid transport element may comprise winding a wire about the liquid transport element to define a plurality of coils wound about the liquid transport element extending between a first wire end and a second wire end. Further, winding the wire about the liquid transport element to define the coils may comprise winding the wire such that a spacing of the coils of the wire is less proximate the first wire end and the second wire end.

In some embodiments assembling the atomizer at operation **906** may comprise coupling a plurality of connector rings to the heating element at the first wire end and the second wire end, wherein connecting the heating element to the heater terminals comprises connecting the heater terminals to the connector rings. In some embodiments connecting the heating element to the heater terminals may comprise connecting the heating element to the heater terminals directly. Further, connecting the atomizer to the base at operation **902** may comprise connecting the heater terminals to the base. Additionally, inserting the atomizer through the cavity at operation **904** may comprise positioning the atomizer such that the heating element is proximate the second reservoir end, the first distal arm and the second distal arm of the liquid transport element and the heater terminals are at least partially received in the cavity, the first liquid transport element end and the second liquid transport element end are proximate the first reservoir end, and the first reservoir end of the reservoir substrate is proximate the base. Inserting the atomizer through the cavity at operation **904** may further comprise inserting the first distal arm and the second distal arm of the liquid transport element in a plurality of grooves extending between the first reservoir end and the second reservoir end of the reservoir substrate at the cavity.

The method may further comprise providing an electronic control component and a control component terminal at operation **908**, connecting the control component terminal to the base at operation **910**, coupling the electronic control component to the control component terminal at operation **912**, and inserting the electronic control component into the cavity of the reservoir substrate at operation **914**. Connecting the control component terminal to the base at operation **910** and connecting the heater terminals to the base may comprise inserting the control component terminal and the heater terminals to a plurality of different heights within the base. Further, connecting the control component terminal to the base at operation **910** and coupling the electronic control component to the control component terminal at operation **912** may be conducted before connecting the heater terminals to the base. The method may further comprise inserting the atomizer through a retainer clip configured to retain the liquid transport element in contact with the heater terminals at operation **916**. Additionally, the method may include providing an external shell and a mouthpiece at operation **918** and coupling the external shell to the base and coupling the mouthpiece to the external shell at operation **920**.

26

In some embodiments the method described above and various other embodiments of methods for assembling a cartridge for a smoking article may be substantially automated. For example, an assembly line may employ a plurality of substations to automatically assemble the cartridge. A first substation may provide the base. A second substation may insert the control component terminal into the base. A third substation may insert the heater terminals into the base. A fourth substation may couple the electronic control component to the control component terminal. A fifth substation may attach the flow tube to the electronic control component and the heater terminals. A sixth substation may cut the heating element and the liquid transport element and laser weld the heating element to the heater terminals. A seventh substation may bend the distal arms of the liquid transport element into contact with the heater terminals. An eighth substation may electrically test the atomizer to determine whether it defines a desired resistance. A ninth substation may flow test the assembly to determine if it defines a desired pressure drop. A tenth substation may couple the reservoir substrate to the assembly and couple a sleeve around the reservoir substrate. An eleventh substation may couple the sleeve to the base, for example by crimping the sleeve thereon. A twelfth substation may flow test the assembly to determine if it defines a desired pressure drop. A thirteenth substation may couple a shipping plug to the base to protect the base during shipment.

Thereafter, the assembly created by the above-described substations may be transported to a second assembly line. The second assembly line may include a first substation that brings a mouthpiece into contact with the sleeve. A second substation may press the mouthpiece into the sleeve. A third substation may crimp the sleeve to retain the mouthpiece in place. A fourth substation may laser mark the sleeve and visually inspect the assembly. A fifth substation may wrap a label around the assembly and visually inspect the assembly to determine if the label is properly positioned. A sixth substation may insert a shipping plug into the mouthpiece. A seventh substation may off-load the completed assemblies and separate out rejects. However, it should be understood that the above-described operations may be performed in other manners by other combinations of substations, in other orders, and/or with a greater or smaller number of assembly lines.

In the various embodiments described above, the heating element is generally described as comprising a wire wound about a liquid transport element and defining a plurality of coils thereon. However, various other embodiments of heating elements may be employed. In this regard, various other embodiments of heating elements and methods and inputs for the production thereof are provided below.

By way of example, FIG. **26** illustrates an input **1000** for production of a plurality of atomizers. As illustrated, the input **1000** may comprise a carrier **1002** defining a plurality of access windows **1004** spaced apart along a longitudinal axis **1006** of the carrier. The input **1000** may further comprise a plurality of heating elements **1008** that are coupled to the carrier **1002** and respectively received in the access windows **1004**.

In some embodiments the carrier **1002** and the heating elements **1008** may be integrally formed from a sheet of a material. The material defining the sheet may comprise a material configured to produce heat when an electrical current is applied thereto. For example, the material may comprise Kanthal (FeCrAl), Nichrome, Molybdenum disilicide (MoSi₂), molybdenum silicide (MoSi), Molybdenum disilicide doped with Aluminum (Mo(Si,Al)₂), or ceramic (e.g., a

positive temperature coefficient ceramic). However, various other materials may be employed in other embodiments.

Various embodiments of operations may be performed to produce the input **1000**. For example, the sheet of the material may be cut (e.g., die or laser cut), stamped, and/or various other operations may be performed thereon. Accordingly, the input **1000** may be produced in a relatively simple manner, which may be repeated on a large scale to produce a number of the inputs, or a continuous roll of the input.

As further illustrated in FIG. 26, the carrier **1002** may comprise a first side strip **1010a** and a second side strip **1010b** (collectively, "side strips **1010**") extending parallel to the longitudinal axis **1006** of the carrier **1002**. The side strips **1010** may be employed to impart motion to the input **1000** along the longitudinal axis **1006** of the carrier **1002** during use thereof to produce atomizers. For example, pairs of counter-rotating wheels may engage the side strips **1010**. In another embodiment one or both of the side strips **1010** may include a plurality of apertures **1012** extending therethrough. Thus, by way of example, the apertures **1012** may be engaged by protrusions on rotating wheels in order to impart motion to the input **1000** along the longitudinal axis **1006** of the carrier **1002**.

In some embodiments the carrier **1002** may further comprise a plurality of connecting strips **1014** extending between the first side strip **1010a** and the second side strip **1010b** and separating the access windows **1004**. For example, in the illustrated embodiment the connecting strips **1014** are configured perpendicularly to the side strips **1010**. The connecting strips **1014** may provide the input **1000** with support and stability. As illustrated in FIG. 26, in some embodiments a first end **1016** and a second end **1018** of each of the heating elements **1008** may be respectively coupled to one of the connecting strips **1014**. Thus, connections between the ends **1016**, **1018** of the heating elements **1008** and the connecting strips **1014** may be retained when the input **1000** is formed from the sheet of the material. Accordingly, in one embodiment the heating elements **1008** may be directly supported by the connecting strips **1014** and indirectly supported by the side strips **1010**, to which the connecting strips couple. In this embodiment, longitudinal axes **1020** of each of the heating elements **1008** may be coaxial with the longitudinal axis **1006** of the carrier **1002**.

FIG. 27 illustrates an enlarged view of one of the heating elements **1008** with the remainder of the input **1000** not shown for clarity purposes. Note that the heating element **1008** may be produced without first being formed as a part of the input **1000**. In this regard, the heating elements **1008** may still be produced from a sheet of a material, but the heating elements may be separated from one another or provided in differing connected forms in some embodiments of the present disclosure.

The heating element **1008** may comprise the first end **1016**, the second end **1018**, and a plurality of interconnected loops **1022** connected to the first end and the second end through a first connector section **1023a** and a second connector section **1023b** (collectively, "connector sections **1023**"). The connector sections **1023** may couple the ends **1016**, **1018** to the loops **1022**. As illustrated in FIG. 27, in some embodiments the loops **1022** may be oriented transversely to the longitudinal axis **1020** of the heating element **1008** and the connector sections **1023**. In other words, the loops **1022** may generally extend perpendicularly relative to the longitudinal axis **1020** of the heating element **1008** and the connector sections **1023**.

As further illustrated in FIG. 27, the loops **1022** may be alternately disposed with respect to the longitudinal axis **1020** and the connector sections **1023**. In this regard, as

illustrated in FIG. 27, a first loop **1022a** may be positioned on a first side **1024** of the longitudinal axis **1020** and the connector sections **1023**, and a second loop **1022b** may be positioned on an opposing second side **1026** of the longitudinal axis and the connector sections. This pattern may be repeated for one or more additional loops **1022**.

As noted above, the input **1000** as a whole, including the heating elements **1008** may be formed from a single sheet of a material. In this regard, the first end **1016**, the second end **1018**, the connector sections **1023**, and the interconnected loops **1022** may be integrally formed from the sheet of the material. As noted above, various embodiments of materials may be employed. For example, the sheet may comprise Kanthal (FeCrAl), Nichrome, Molybdenum disilicide (MoSi₂), molybdenum silicide (MoSi), Molybdenum disilicide doped with Aluminum (Mo(Si,Al)₂), and ceramic (e.g., a positive temperature coefficient ceramic). In this regard, the material may be configured to produce heat when electrical current is applied therethrough. Further, in some embodiments the material may be configured to bend, as described below. In some embodiments the material of the sheet may be a metal material.

In some embodiments the first end **1016** and the second end **1018** of the heating element **1008** may define a width **1028** that is greater than a width **1030** of the material defining the interconnected loops **1022** and the connector sections **1023**. Providing the first end **1016** and the second end **1018** of the heating elements **1008** with a greater width **1028** than the width **1030** of the material defining the interconnected loops **1022** and the connecting sections **1023** may provide the first end and the second end with a relatively larger surface area that may facilitate connection of the heating elements to heater terminals. For example, welding and/or other methods of coupling the heating elements **1008** to the heater terminals may be employed, as described elsewhere herein.

The heating elements **1008** may be at least partially bent around a liquid transport element in order to form an atomizer. In some embodiments the heating elements **1008** may be pre-bent prior to coupling to a liquid transport element such that they are received partially about the liquid transport element prior to completion of bending thereabout. In this regard, FIG. 26 illustrates a first portion **1034** of the heating elements **1008** in an initial planar configuration and a second portion **1036** of the heating elements are illustrated as having been pre-bent from the initial planar configuration to an intermediate, pre-bent configuration. In the intermediate configuration, at least a part of the interconnected loops **1022** may be oriented in a non-planar configuration relative to a remainder of the input **1000**. For example, at least a portion of the interconnected loops **1022** may be oriented substantially perpendicular to a plane defined by the remainder of the input **1000** such that the interconnected loops oppose one another. Accordingly, the pre-bent heating elements **1008** may receive a liquid transport element between the opposing interconnected loops **1022**. However, in other embodiments the heating elements **1008** may be wrapped about the liquid transport element without first pre-bending the interconnected loops. For example, the heating elements **1008** may be bent from the planar configuration to a configuration in which the interconnected loops **1022** at least partially wrap about the liquid transport element without first being bent to an intermediate configuration.

Regardless of whether the interconnected loops **1022** are pre-bent to the intermediate configuration, the interconnected loops may ultimately be wrapped at least partially around a liquid transport element. By way of example, FIG. 28 illustrates one of the heating elements **1008** in a fully bent con-

29

figuration. Note that in the fully bent configuration, the heating elements **1008** may be wrapped around a liquid transport element. However, the liquid transport element is not shown in FIG. **28** for clarity purposes.

As illustrated in FIG. **28**, the interconnected loops **1020** may be bent such that a plurality of tips **1038** of the interconnected loops are positioned adjacent one another. Further, the interconnected loops **1022** may define a substantially cylindrical void **1040** extending parallel to the longitudinal axis **1020** of the heating element **1008** and the connector sections **1023**. The substantially cylindrical void **1040** may be configured to define a radius substantially equal to a radius of the liquid transport element about which the interconnected loops **1022** are wrapped, such that the heating element **1008** may be retained thereon. Note that in the bent configuration, the connector sections **1023** and the ends **1016**, **1018** may remain in a substantially planar configuration.

A second embodiment of an input **1100** for production of a plurality of atomizers is illustrated in FIG. **29**. As illustrated, the input **1100** illustrated in FIG. **29** may be substantially similar to the input **1000** illustrated in FIG. **26**. Accordingly, similar features of the input **1100** will not be described in detail, and only differences therebetween will be highlighted.

In this regard, as illustrated in FIG. **29**, the input **1100** may comprise a carrier **1102** defining a plurality of access windows **1104** spaced apart along a longitudinal axis **1106** of the carrier. The input **1100** may further comprise a plurality of heating elements **1108** that are coupled to the carrier **1102** and respectively received in the access windows **1104**. The carrier **1102** may comprise a first side strip **1110a** and a second side strip **1110b** (collectively, "side strips **1110**") extending parallel to the longitudinal axis **1106**. The side strips **1110** may include a plurality of apertures **1112** extending therethrough.

The carrier **1102** may further comprise a plurality of connecting strips **1114** extending between the first side strip **1110a** and the second side strip **1110b** (e.g., perpendicularly thereto) and separating the access windows **1104**. In the embodiment of the input **1000** described above and illustrated in FIG. **26**, the ends **1016**, **1018** of each of the heating elements **1008** are respectively coupled to one of the connecting strips **1014**. In contrast, in the embodiment of the input **1100** illustrated in FIG. **29**, a first end **1116** and a second end **1118** of each of the heating elements **1108** are respectively coupled to one of the first side strip **1110a** and the second side strip **1110b**. Thus, the heating elements **1108** may be directly coupled to and supported by the side strips **1110** in some embodiments. In this embodiment, connections between the ends **1116**, **1118** of the heating elements **1108** and the side strips **1110** may be retained when the input **1100** is formed.

Further, a plurality of longitudinal axes **1120** of the heating elements **1108** may be perpendicular to the longitudinal axis **1106** of the carrier **1102**. Each of the longitudinal axes **1120** of the heating elements **1108** may be parallel with one another in some embodiments. A plurality of interconnected loops **1122** may be respectively connected to the first end **1116** and the second end **1118** by a first connector section **1123a** and a second connector section **1123b** (collectively, "connector sections **1123**"). The interconnected loops **1122** may be oriented transversely to the longitudinal axes **1120** of the heating elements **1108** and the connector sections **1123** and alternately disposed with respect thereto.

A first portion **1134** of the input **1100** is illustrated with the interconnected loops **1122** of the heating elements **1108** in an unbent, planar configuration. In contrast, a second portion **1136** of the input **1100** is illustrated with the interconnected loops **1122** in a pre-bent configuration. As described above,

30

the input **1100** may be provided in either the planar or pre-bent configurations prior to being wrapped about a liquid transport element.

FIG. **30** illustrates production of atomizers according to an example embodiment of the present disclosure. In the illustrated embodiment, by way of example, a cartridge subassembly **1200'** comprising a base **1202** with an electronic control component **1206** and first and second heater terminals **1230a**, **1230b** (collectively, "heater terminals **1230**") coupled thereto is provided. The electronic control component **1206** may be coupled to the base **1202** via a control component terminal **1204**.

A liquid transport element **1226** may also be provided. In some embodiments the liquid transport element **1226** may be at least partially engaged with the heater terminals **1206** prior to coupling the heating element **1108** thereto. In this regard, FIG. **30** illustrates a cartridge subassembly **1200'** comprising the components of the cartridge subassembly **1200'** in addition to the liquid transport element **1226**. As illustrated, a first distal arm **1240a** and a second distal arm **1240b** (collectively, "distal arms **1240**") of the liquid transport element **1226** may be engaged with the heater terminals **1230** and a center section **1240c** of the liquid transport element may extend therebetween. Accordingly, the liquid transport element **1226** may be transported to one or more assembly stations by moving the base **1202**. Alternatively or additionally, the base **1202** may be employed to hold the liquid transport element **1226** in a position that assists in attachment of one of the heating elements **1108** thereto.

The cartridge subassembly **1200'** may then be moved into proximity with the input **1100**. More particularly, one of the heating elements **1108** may be brought into proximity with the center section **1240c** of the liquid transport element **1226**. Thereby, the interconnected loops **1122** of the heating element **1108** may be at least partially wrapped around the liquid transport element **1226**. For example, a pair of actuators may extend into one of the access windows **1104** and compress the interconnected loops **1122** against the liquid transport element **1226**. In some embodiments the actuators may define a profile configured to match a profile of the liquid transport element **1226**. For example, the actuators may define actuating surfaces configured to engage the heating element **1108** that define a radius substantially equal to a radius of the liquid transport element **1226**. However, the liquid transport may define cross-sectional shapes other than rounded in other embodiments, and the actuators configured to bend the heating element may be appropriately configured to match the particular cross-sectional shape. During the bending operation of the heating element **1108** about the liquid transport element **1226**, the ends **1116**, **1118** of the heating element may remain connected to the carrier **1102**. Accordingly, the heating element **1108** may be supported by the carrier **1102** during the bending operation such that issues with respect to retaining the heating element in the proper position may be averted.

Thereafter, the ends **1116**, **1118** of the heating element **1108** may be decoupled from the carrier **1102** and the ends of the heating element may be connected to the heater terminals **1230** to form an atomizer **1208**, as illustrated at cartridge subassembly **1200''**. Additional cartridge subassemblies **1200'''** with atomizers **1208** may be produced by repeating the procedures noted above and incrementing the position of the input **1100** such that the next heating element **1108** may be provided in an appropriate position. For example, in the embodiment illustrated in FIG. **30**, the input **1100** may be incremented generally into the page and to the left.

31

Accordingly, use of the above-described embodiments of heating elements formed from a sheet of a material may be beneficial in that it may eliminate the need to conduct winding operations in which a wire is wound about a liquid transport element. In this regard, winding a wire about a liquid transport element to form a heating element may require a relatively high degree of precision. Further, handling of the wire, which may define a relatively small diameter, may be difficult. In contrast, the formation of heating elements from a sheet of material may only involve relatively simple cutting operations, which may allow for repeatable mass production thereof. Further, the attachment of the heating elements to the liquid transport element may be simplified by employing the carrier to hold the heating elements. Thus, the heating elements may be easily transported to a desired position by moving the carrier. Further, the carrier may support the heating element during attachment to the liquid transport element. Accordingly, use of heating elements formed from a sheet of a material may simplify production of cartridges for a smoking article.

A method of forming a plurality of atomizers is also provided. As illustrated in FIG. 30, the method may comprise providing a sheet of a material at operation 1300. The method may further include forming the sheet of the material into a carrier defining a plurality of access windows spaced apart along a longitudinal axis of the carrier at operation 1302. Additionally, the method may include forming the sheet of the material into a plurality of heating elements that are coupled to the carrier and respectively received in the access windows at operation 1304.

In some embodiments the method may further comprise providing a liquid transport element at operation 1306. The method may additionally include bending the interconnected loops about the liquid transport element at operation 1308. A plurality of tips of the interconnected loops may be positioned adjacent one another and the interconnected loops may define a substantially cylindrical void extending parallel to the longitudinal axis of the carrier in which the liquid transport element is received in some embodiments. The method may additionally include decoupling the heating elements from the carrier at operation 1310 and connecting a first end and a second end of each of the heating elements to a plurality of heater terminals at operation 1312.

In some embodiments of the method, forming the sheet of the material into the carrier at operation 1302 may comprise forming a first side strip and a second side strip extending parallel to the longitudinal axis. Further, forming the sheet of the material into the carrier at operation 1302 and forming the sheet of the material into the heating elements at operation 1304 may comprise retaining a plurality of connections between a first end and a second end of the heating elements and the first side strip and the second side strip. Additionally, forming the sheet of the material into the carrier at operation 1302 may comprise forming a plurality of apertures extending through at least one of the first side strip and the second side strip.

In some embodiments of the method, forming the sheet of the material into the carrier at operation 1302 may comprise forming a plurality of connecting strips extending between the first side strip and the second side strip and separating the access windows. Further, forming the sheet of the material into the carrier at operation 1302 and forming the sheet of the material into the heating elements at operation 1304 may comprise retaining a plurality of connections between a first end and a second end of each of the heating elements and the connecting strips. Additionally, forming the sheet of the material into the heating elements at operation 1304 may

32

comprise forming a plurality of interconnected loops oriented transversely to a plurality of longitudinal axes of the heating elements. Forming the sheet of the material into the heating elements at operation 1304 may also comprise forming the heating elements such that the longitudinal axes thereof are coaxial with the longitudinal axis of the carrier. In another embodiment, forming the sheet of the material into the heating elements at operation 1304 may comprise forming the heating elements such that the longitudinal axes thereof are perpendicular to the longitudinal axis of the carrier.

In an additional aspect, a controller configured to execute computer code for performing the above-described operations is provided. The controller may comprise a processor that may be a microprocessor or a controller for controlling the overall operation thereof. In one embodiment the processor may be particularly configured to perform the functions described herein. The controller may also include a memory device. The memory device may include non-transitory and tangible memory that may be, for example, volatile and/or non-volatile memory. The memory device may be configured to store information, data, files, applications, instructions or the like. For example, the memory device could be configured to buffer input data for processing by the processor. Additionally or alternatively, the memory device may be configured to store instructions for execution by the processor.

The controller may also include a user interface that allows a user to interact therewith. For example, the user interface can take a variety of forms, such as a button, keypad, dial, touch screen, audio input interface, visual/image capture input interface, input in the form of sensor data, etc. Still further, the user interface may be configured to output information to the user through a display, speaker, or other output device. A communication interface may provide for transmitting and receiving data through, for example, a wired or wireless network such as a local area network (LAN), a metropolitan area network (MAN), and/or a wide area network (WAN), for example, the Internet.

The controller may also include atomizer forming module. The processor may be embodied as, include or otherwise control the atomizer forming module. The atomizer forming module may be configured for controlling or executing the atomizer forming operations described herein.

The various aspects, embodiments, implementations or features of the described embodiments can be used separately or in any combination. Various aspects of the described embodiments can be implemented by software, hardware or a combination of hardware and software. The described embodiments can also be embodied as computer readable code on a computer readable medium for controlling atomizer forming operations. In this regard, a computer readable storage medium, as used herein, refers to a non-transitory, physical storage medium (e.g., a volatile or non-volatile memory device, which can be read by a computer system. Examples of the computer readable medium include read-only memory, random-access memory, CD-ROMs, DVDs, magnetic tape, and optical data storage devices. The computer readable medium can also be distributed over network-coupled computer systems so that the computer readable code is stored and executed in a distributed fashion.

Thus, an embodiment of a non-transitory computer readable medium for storing computer instructions executed by a processor in a controller for an apparatus configured to form atomizers is provided. The non-transitory computer readable medium may comprise computer code for providing a sheet of a material, computer code for forming the sheet of the material into a carrier defining a plurality of access windows spaced apart along a longitudinal axis of the carrier, and

computer code for forming the sheet of the material into a plurality of heating elements that are coupled to the carrier and respectively received in the access windows.

In some embodiments the non-transitory computer readable medium may further comprise computer code for providing a liquid transport element and computer code for bending the interconnected loops about the liquid transport element such that a plurality of tips of the interconnected loops are positioned adjacent one another and the interconnected loops define a substantially cylindrical void extending parallel to the longitudinal axis of the carrier. The non-transitory computer readable medium may further comprise computer code for decoupling the heating elements from the carrier and computer code for connecting a first end and a second end of each of the heating elements to a plurality of heater terminals.

Additionally, in some embodiments the computer code for forming the sheet of the material into the carrier may comprise computer code for forming a first side strip and a second side strip extending parallel to the longitudinal axis. Computer code for forming the sheet of the material into the carrier and computer code for forming the sheet of the material into the heating elements may comprise computer code for retaining a plurality of connections between a first end and a second end of the heating elements and the first side strip and the second side strip. Computer code for forming the sheet of the material into the carrier may comprise computer code for forming a plurality of apertures extending through at least one of the first side strip and the second side strip. Computer code for forming the sheet of the material into the carrier may comprise computer code for forming a plurality of connecting strips extending between the first side strip and the second side strip and separating the access windows.

In some embodiments computer code for forming the sheet of the material into the carrier and computer code for forming the sheet of the material into the heating elements may comprise computer code for retaining a plurality of connections between a first end and a second end of each of the heating elements and the connecting strips. Computer code for forming the sheet of the material into the heating elements may comprise computer code for forming a plurality of interconnected loops oriented transversely to a plurality of longitudinal axes of the heating elements. Computer code for forming the sheet of the material into the heating elements may comprise computer code for forming the heating elements such that the longitudinal axes thereof are coaxial with the longitudinal axis of the carrier. Computer code for forming the sheet of the material into the heating elements may comprise computer code for forming the heating elements such that the longitudinal axes thereof are perpendicular to the longitudinal axis of the carrier.

Many modifications and other embodiments of the disclosure will come to mind to one skilled in the art to which this disclosure pertains having the benefit of the teachings presented in the foregoing descriptions and the associated drawings. Therefore, it is to be understood that the disclosure is not to be limited to the specific embodiments disclosed herein and that modifications and other embodiments are intended to be included within the scope of the appended claims. Although specific terms are employed herein, they are used in a generic and descriptive sense only and not for purposes of limitation.

The invention claimed is:

1. A cartridge for an aerosol delivery device, the cartridge comprising:

a base defining a connector end configured to engage a control body;

a reservoir substrate configured to hold an aerosol precursor composition, the reservoir substrate defining a cavity extending therethrough from a first reservoir end to a second reservoir end, wherein the first reservoir end is positioned proximate the base;

and an atomizer comprising a liquid transport element extending between a first liquid transport element end and a second liquid transport element end and a heating element extending at least partially about the liquid transport element at a position between the first liquid transport element end and the second liquid transport element end, the atomizer extending through the cavity of the reservoir substrate such that the heating element is positioned proximate the second reservoir end and the first liquid transport element end and the second liquid transport element end are positioned proximate the first reservoir end;

wherein the atomizer further comprises a plurality of heater terminals connected to the base and the heating element;

wherein the cartridge further comprises a retainer clip surrounding the atomizer and configured to retain the liquid transport element in contact with the heater terminals.

2. The cartridge of claim 1, wherein the reservoir substrate defines a plurality of grooves at the cavity extending between the first reservoir end and the second reservoir end and configured to receive the liquid transport element.

3. The cartridge of claim 1, wherein the heater terminals extend through the reservoir substrate.

4. The cartridge of claim 1, further comprising an electronic control component and a control component terminal coupled thereto, wherein the electronic control component is received in the cavity of the reservoir substrate and the control component terminal is connected to the base.

5. The cartridge of claim 4, wherein the control component terminal and the heater terminals extend to a plurality of different depths within the base.

6. The cartridge of claim 1, wherein the heating element comprises a wire defining a plurality of coils wound about the liquid transport element extending between a first wire end and a second wire end.

7. The cartridge of claim 6, wherein the atomizer further comprises a plurality of connector rings surrounding the heating element at the first wire end and the second wire end, wherein the heater terminals engage the connector rings.

8. The cartridge of claim 6, wherein the heater terminals directly contact the wire proximate the first wire end and the second wire end.

9. The cartridge of claim 8, wherein a spacing of the coils of the wire is less proximate the first wire end and the second wire end.

10. The cartridge of claim 1, further comprising a mouthpiece and an external shell.

11. A method for assembling a cartridge for an aerosol delivery device, the method comprising:

providing a base defining a connector end configured to engage a control body, an atomizer, and, a reservoir substrate configured to hold an aerosol precursor composition and defining a cavity extending therethrough from a first reservoir end to a second reservoir end;

connecting the atomizer to the base;

inserting the atomizer through the cavity through the reservoir substrate;

assembling the atomizer, wherein assembling the atomizer comprises:

providing a plurality of heater terminals, a liquid transport element extending between a first liquid transport

35

element end and a second liquid transport element end, and a heating element;
 wrapping the heating element at least partially about the liquid transport element; and
 connecting the heating element to the heater terminals such that the heating element extends therebetween and a first distal arm of the liquid transport element and a second distal arm of the liquid transport element extend along the heater terminals; and
 inserting the atomizer through a retainer clip configured to retain the liquid transport element in contact with the heater terminals,
 wherein connecting the atomizer to the base comprises connecting the heater terminals to the base, and
 wherein inserting the atomizer through the cavity comprises positioning the atomizer such that the heating element is proximate the second reservoir end, the first distal arm and the second distal arm of the liquid transport element and the heater terminals are at least partially received in the cavity, the first liquid transport element end and the second liquid transport element end are proximate the first reservoir end, and the first reservoir end of the reservoir substrate is proximate the base.

12. The method of claim **11**, wherein inserting the atomizer through the cavity further comprises inserting the first distal arm and the second distal arm of the liquid transport element in a plurality of grooves extending between the first reservoir end and the second reservoir end of the reservoir substrate at the cavity.

13. The method of claim **11**, further comprising providing an electronic control component and a control component terminal;
 connecting the control component terminal to the base;
 coupling the electronic control component to the control component terminal; and

36

inserting the electronic control component into the cavity of the reservoir substrate.

14. The method of claim **13**, wherein connecting the control component terminal to the base and connecting the heater terminals to the base comprise inserting the control component terminal and the heater terminals to a plurality of different heights within the base.

15. The method of claim **13**, wherein connecting the control component terminal to the base and coupling the electronic control component to the control component terminal are conducted before connecting the heater terminals to the base.

16. The method of claim **11** wherein wrapping the heating element at least partially about the liquid transport element comprises winding a wire about the liquid transport element to define a plurality of coils wound about the liquid transport element extending between a first wire end and a second wire end.

17. The method of claim **16**, further comprising coupling a plurality of connector rings to the heating element at the first wire end and the second wire end, wherein connecting the heating element to the heater terminals comprises connecting the heater terminals to the connector rings.

18. The method of claim **16**, wherein connecting the heating element to the heater terminals comprises connecting the heating element to the heater terminals directly.

19. The method of claim **16**, wherein winding the wire about the liquid transport element to define the coils comprises winding the wire such that a spacing of the coils of the wire is less proximate the first wire end and the second wire end.

20. The method of claim **11**, further comprising providing an external shell and a mouthpiece; and
 coupling the external shell to the base and coupling the mouthpiece to the external shell.

* * * * *